

INTRODUCTION

The Total Indoor Air Quality Monitor will monitor up to 6 parameters that include Particulate Matter (PM1, PM2.5, PM4 & PM10), Volatile Organic Compounds, Carbon Dioxide, Formaldehyde, Humidity & Temperature and provide either a BACnet® or Modbus signal for connection to a building automation system. The IAQ features a full-colour capacitive touch screen LCD that's user configurable, a configurable alarm relay output and field replaceable sensor modules. All this housed in a new modern, quick mount enclosure.

WARNING

Read these installation instructions carefully before commissioning the IAQ. Failure to follow these instructions may result in product damage. Do not use in an explosive or hazardous environment, with combustible or flammable gases, as safety or emergency stop devices or in any other application where failure of the product could result in personal injury. Use electrostatic discharge precautions during installation and do not exceed the device ratings.

MOUNTING

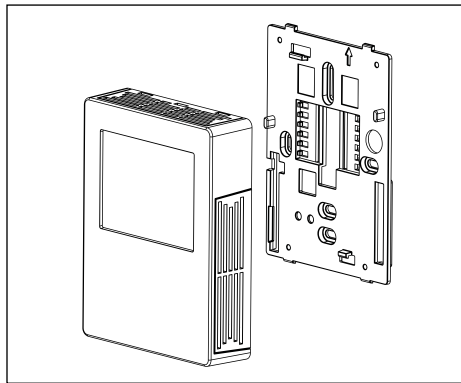

1 Included is the backplate and sensor module/cover. **Do not separate sensor module and cover.**

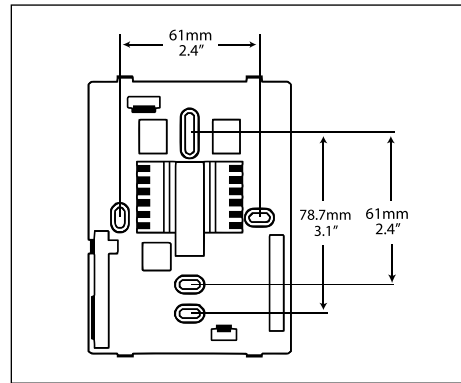

2 The backplate includes mounting holes for several mounting box types.

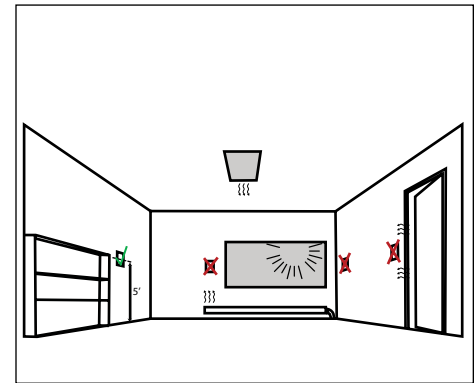

3 The sensor should be mounted 1.5 m (5') from the floor of the area to be controlled. Do not mount the sensor near doors, opening windows, supply air diffusers or other known disturbances. Avoid areas where the detector is exposed to vibrations or rapid temperature changes.

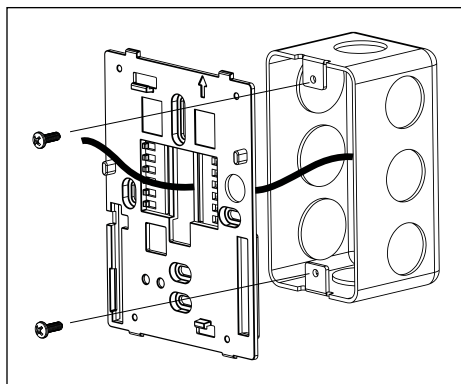

3 Feed control wire through the center hole and mount backplate to an electrical box with 2 screws (not supplied).

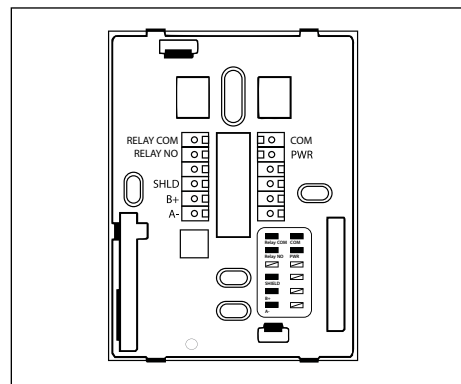

4 The backplate contains the wiring terminals and terminal designations.

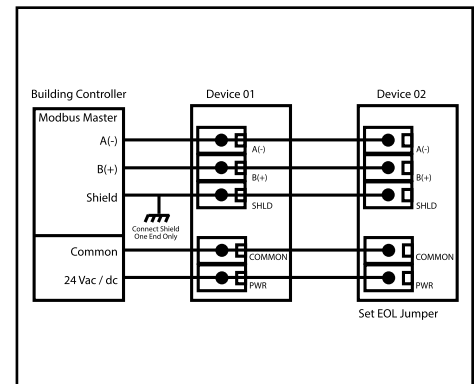

Typical Network Wiring

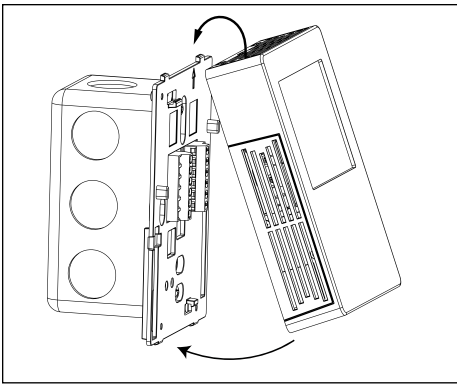

5 NOTE: The sensor module can be installed with power applied, but it is not recommended. To Install sensor module/cover by placing the tabs on the top of backplate into slots in the sensor module/cover and snap onto tabs on bottom of backplate

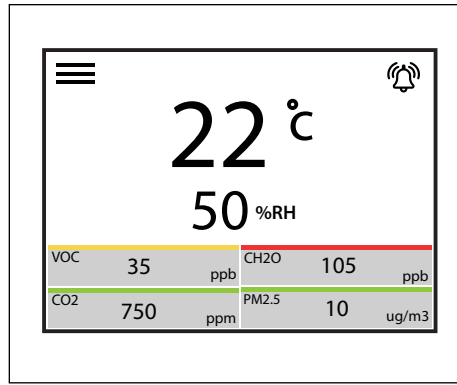

6 If power is present the LCD will illuminate and after about 10 seconds, the sensor readings will be displayed. Allow 24 hours for sensors to stabilize for accurate readings.

LCD BACKLIGHT

The LCD Backlight default is ON. To turn OFF refer to the Network Setup Guide. In the OFF setting, the LCD backlight remains OFF and when the LCD is touched turns on for 2 minutes.

For devices with the Concealed LCD, the LCD Backlight default is OFF.

NETWORK CONFIGURATION

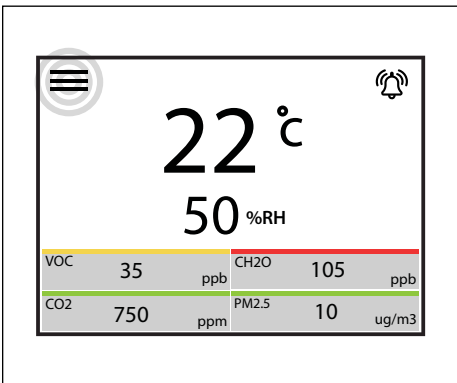

1 To configure, select the menu icon in the top left of display.

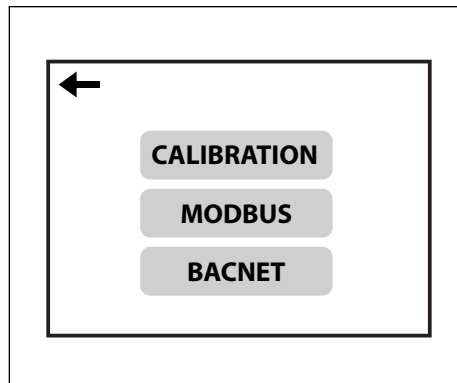

2 Select network system type. BACnet® or Modbus

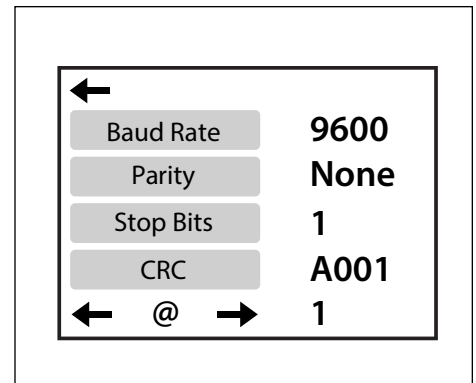

3 MODBUS For a Modbus network, required parameters are Baud Rate, Parity Value, Stop Bits, CRC Value & Address

MODBUS
Baud Rate range: 9600, 19200, 38400, 57600, 76800 or 115200. The default network baud rate is 9600.
Parity Value: None, Odd or Even. The default Modbus parity bit is None
Stop Bits: 1 or 2. The default Modbus stop bits is 1.
CRC Value: A001 (CRC-16 reverse), 1021 (CITT), 8005 (CRC-16) or 8408 (CITT reverse). The default CRC is A001.
Address: 1-255. The default address is 1.

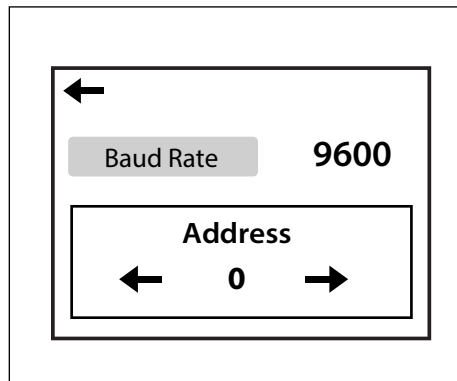

4 BACNET® For a BACnet® network, required parameters are Baud Rate & Address

BACnet®
Baud Rate range: 9600, 19200, 38400, 57600, 76800 or 115200. The default network baud rate is 9600.
Address: 0-127. The default address is 0.

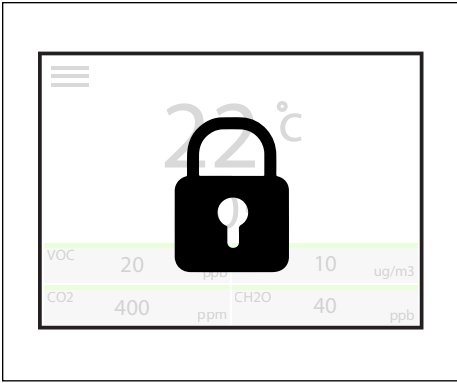

5 After initial setup, the touchscreen can be locked during network set up via the network to avoid any unauthorized access. See Network Setup Guide.

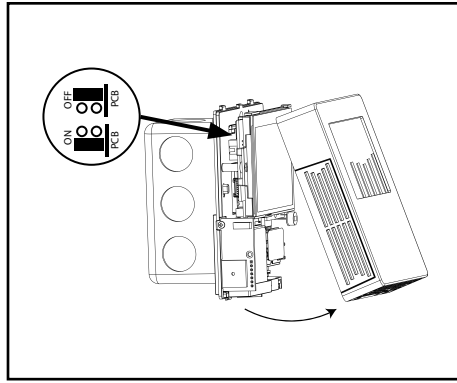

6 This device includes a EOL network termination jumper and will connect the (121 Ω) resistor correctly on the PCB. The default is OFF. Simply move the jumper to the ON position. Remove cover to set the EOL Jumper.

WARNING

The CO2 sensor incorporates a self-calibration feature (ASC) to correct CO2 sensor drift. Use the self-calibration feature for applications where the CO2 sensor is exposed to fresh air (400 ppm) at least 1 hour each day. If the monitored space has 24 hour occupancy or consistently maintains higher or lower levels of CO2, turn off the self-calibration feature and perform a yearly calibration. If you disable the self-calibration feature at installation time without an allowance for the 7 day auto-calibration cycle, then perform a manual calibration to ensure the accuracy of the device. To disable the ASC, refer to the Network Setup Guide.

WARNING

This sensor has multiple settings that can be set or adjusted after installation such as parameter ranges, relay settings, display settings, etc. and can only be completed over the Network.

To set or adjust parameters, refer to the Network Setup Guide.

NETWORK SETUP GUIDE

The network setup guides describe the implementation of the BACnet® or Modbus protocol. They are intended to assist control system programmers who may need to add support to their systems to communicate with the device.

BACnet® and Modbus setup guide download is available online.



BACnet® PROTOCOL

<https://downloads.greystoneenergy.com/SG/SG-IAQXXXBAC-001.pdf>



Modbus PROTOCOL

<https://downloads.greystoneenergy.com/SG/SG-IAQXXXMOD-001.pdf>

DISPLAY

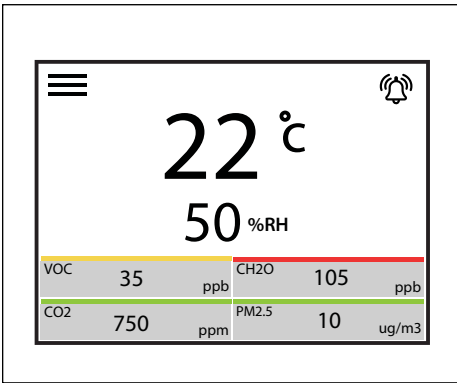

1 The touchscreen display has several features that are configurable during set up. The factory default is all features on. To change features see Network Setup Guide.

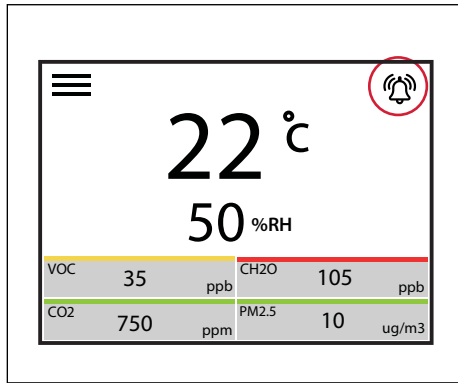

2 Alarm Icon - The alarm icon is tied to the alarm relay. If the alarm relay is not in alarm mode the icon is not shown. If alarm relay is activated the icon is shown. See alarm relay settings to set alarm functions.

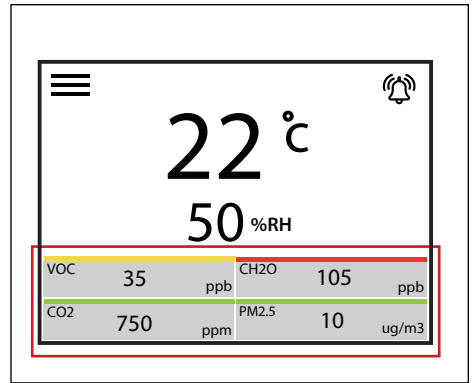

3 Sensor Display - Display of the VOC, PM, CO2 and CH2O are optional. The factory default is all on. Each parameter can be turned off individually during network set up. To change parameter display see Network Setup Guide.

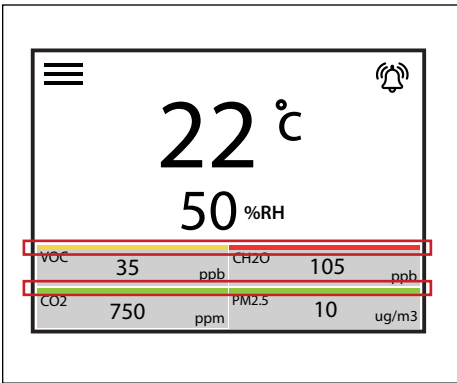

4 Status Bars - The colored status bars for each parameter are displayed as Green, Yellow or Red and change based on preset contamination levels. The factory default is all on. To turn all off see Network Setup Guide. Note: if the parameter displays are turned off in step 3, status bars are also off.

STATUS BAR LEGEND

VOC: <29 ppb - Green
29 to 85 ppb - Yellow
>85 ppb - Red

CO2: <1000 ppm = Green
1000 to 1500 ppm = Yellow
>1500 = Red

PM: <12 ug/m3 = Green
12 to 55 ug/m3 = Yellow
>55 ug/m3 = Red

CH2O: <40 ppb = Green
40 to 100 ppb = Yellow
>100 ppb = Red

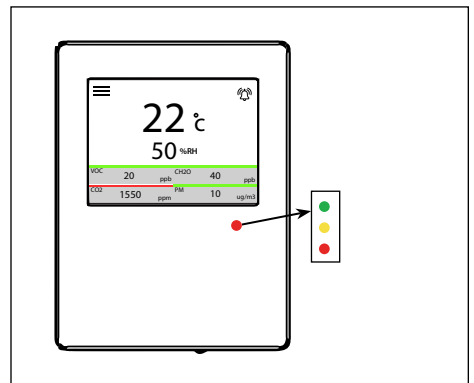

5 LED - A tri-color, Green, Yellow or Red status LED illuminates based on the same preset contamination levels as STEP 4. If any one of the measured parameters changes status, the LED color will change. The factory default is on. To turn off see Network Setup Guide.

SERVICING

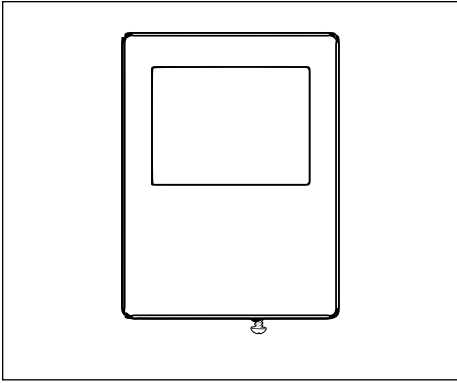

1 For sensor servicing or to remove from wall, loosen the security screw. Complete removal is not required.

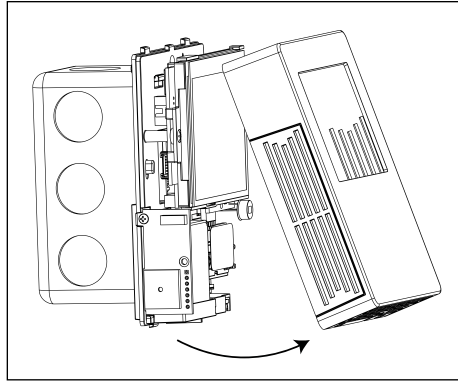

2 Remove cover by pulling outward on bottom and lift off backplate tabs

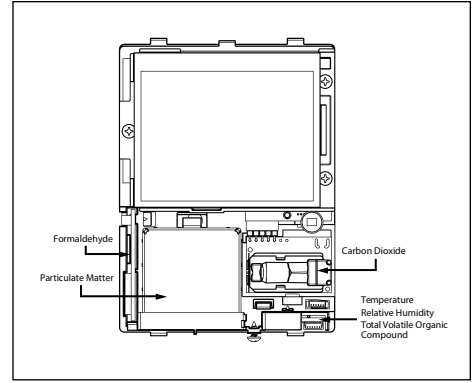

3 There 3 or 4 replaceable sensor modules depending on device purchased. The VOC, RH & Temperature sensor are combined on one module. For sensor module replacement, please refer to the sensor replacement instructions.

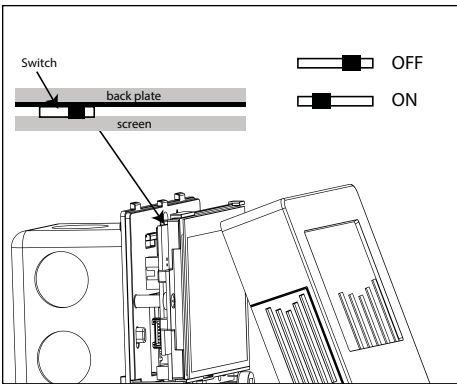

4 The device must be powered off to perform a sensor replacement or removal from the wall. An on/ off switch located on the top left of the device is provided.

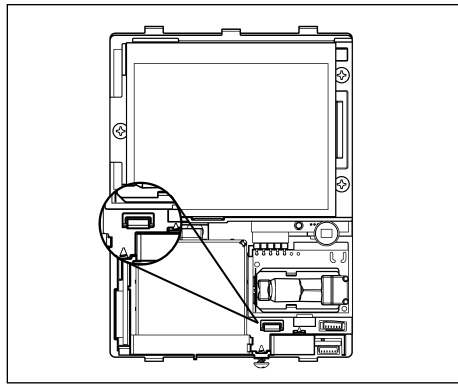

5 To remove device from wall, use a standard screwdriver to gently pry up the locking tab.

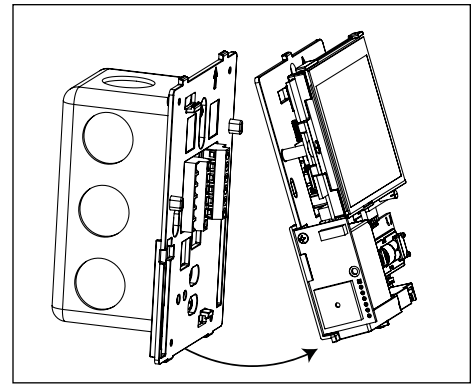

6 While prying gently on locking tab, pull out the bottom of the sensor carriage. The backplate will remain mounted to the wall.

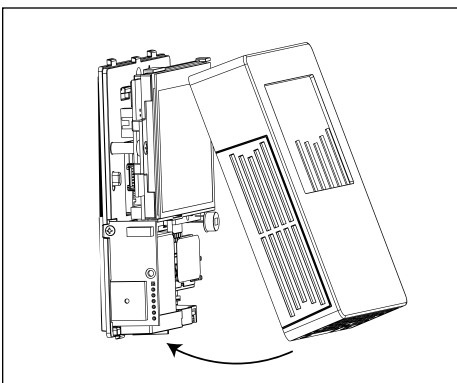

7 To re-install, turn Power Switch to On and attach cover to sensor carriage and tighten security screw before re-installing on the backplate.

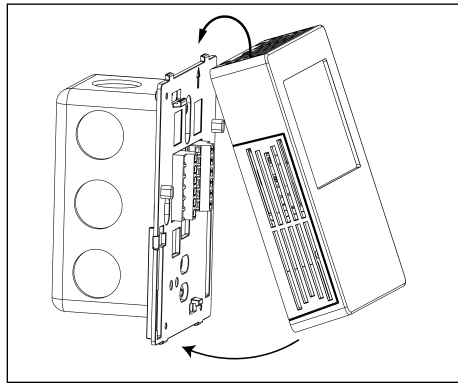

8 Install sensor module/cover by placing the tabs on the top of backplate into slots in the sensor module/cover and snap onto tabs on bottom of backplate

CALIBRATION (CO2 ONLY)

Field calibration can be completed on the CO2 sensor by 2 methods. 1) Using a field calibration kit, CO2 gas and sensor hood (Part# IAQA-CO2HOOD) or 2) By using a handheld CO2 meter or secondary device as a reference. To perform using a field calibration kit, please refer field calibration instructions. To perform using a handheld CO2 meter or secondary device as a reference follow the steps below. To start, perform STEP 1 & 2 from the SERVICING Section.

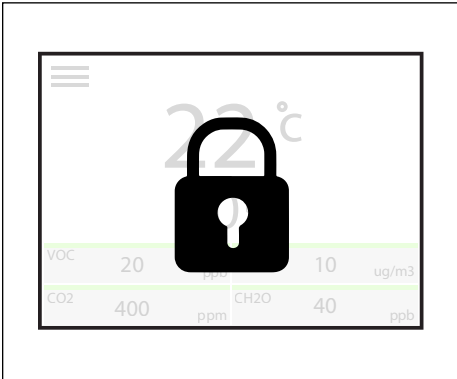

1 If touchscreen is enabled, skip to STEP 3. If touchscreen was disabled during initial set up it will need to be re-enabled via the Network settings, or turning power off and back on will enable the touchscreen for 2 minutes. Entering calibration screen will extend this time indefinitely.

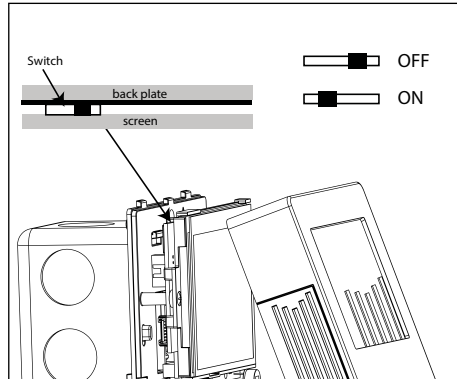

2 An on/ off switch located on the top left of the device is provided. Turn off and back on.

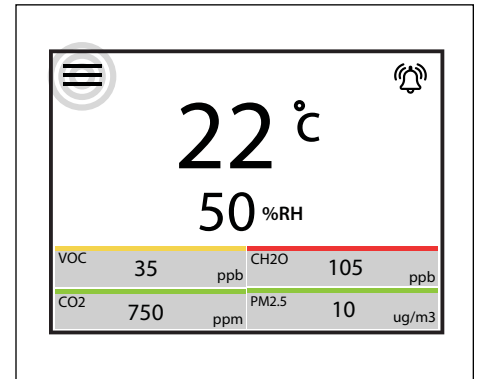

3 Select the menu icon in the top left of display

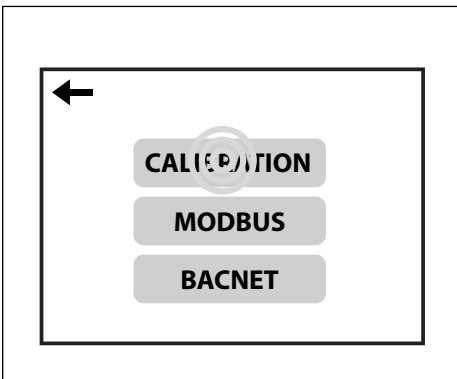

4 Select calibration from the menu items

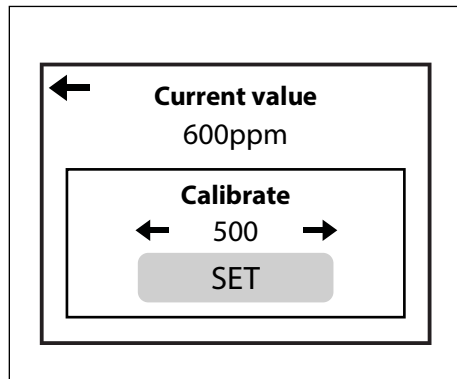

5 Set calibration CO2 level based on reading from handheld CO2 meter or secondary reference device.

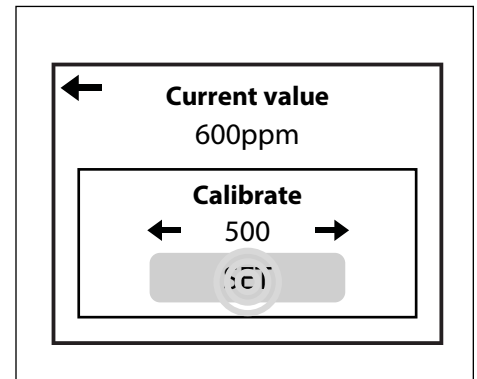

6 Select SET to calibrate the sensor.

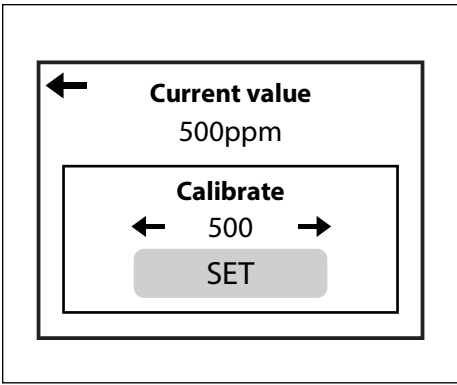

7 When calibration is complete the CURRENT VALUE and SET VALUE will match. Select back arrow in top left of screen to exit to main screen

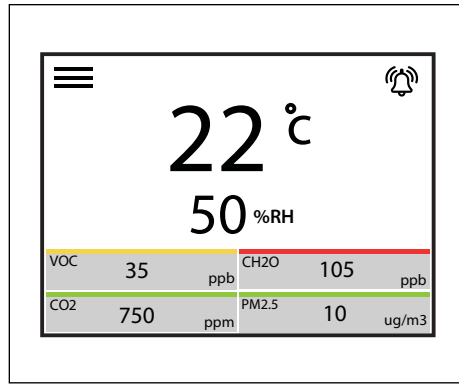

8 If touchscreen lock was set initially and disabled by turning the device off/on, after 2 minutes it will re-enable automatically. If disabled via the Network settings, it will need to be re-enabled via the Network settings.

DIMENSIONS

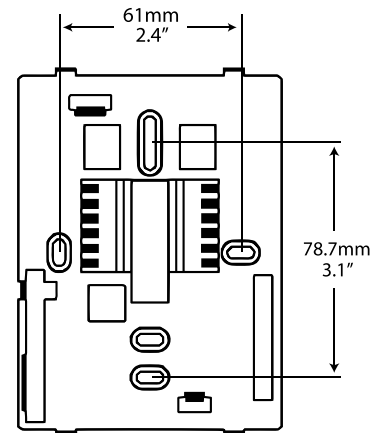
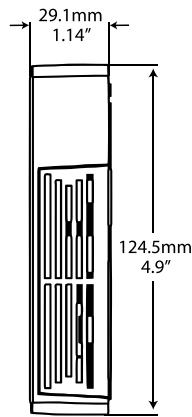
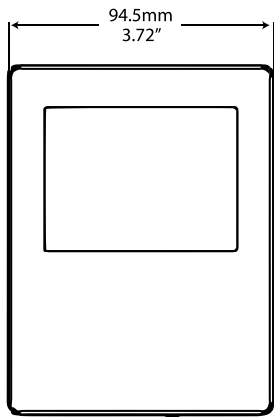

SPECIFICATIONS

PARTICULATE MATTER SENSOR

Type

Laser Scatter Method (Field Replaceable)

Particulate Size

PM1.0, PM2.5, PM4.0 and PM10

Mass Concentration Range

0 - 1000 ug/m³ or 0 - 3000 #/cm³ (Selectable)

Mass Concentration Resolution

1 (ug/m³, 1#/cm³)

Accuracy PM1.0 and PM2.5

±10 ug/m³ (0 - 100 ug/m³), ±10%M.V. (100 - 1000 ug/m³)

Accuracy PM4 and PM10

±25 ug/m³ (0 - 100 ug/m³), ±25%M.V. (100 - 1000 ug/m³)

Sensor Life Expectancy >10 years

CARBON DIOXIDE SENSOR

Type

Dual channel non-dispersive infrared (Field Replaceable)

Accuracy

± (30ppm + 3% of measured value)

Measurement Range

0 - 10000 ppm

Auto-Cal

Selectable On (ASC) or Off (FRC)

Altitude Adjustment

0 - 3000 meters

Calibration

Field calibration capable with calibration kit

Sensor Life Expectancy >15 years

VOLATILE ORGANIC COMPOUNDS SENSOR

Type

MOX metal oxide semiconductor (Field Replaceable)

Range

VOC Index (0 - 500) or TVOC (1300 ppb or 6000 ug/m³)

Resolution

1 (VOCI, PPB, ug/m³)

RELATIVE HUMIDITY SENSOR

Type Thermoset Polymer-based

Capacitance Sensor Chip (Field Replaceable)

Range 0-100% RH

Accuracy ±1.5% RH

Calibration +/-10% Offset

Resolution 0.1% RH

TEMPERATURE SENSOR

Type Bipolar Transistor Sensor Chip

Range 0 - 60°C, 32 - 140°F

Resolution 0.1°C/°F

Accuracy ± 0.2°C, ± 0.4°F (Typical)

Calibration

-5 to 5°C Offset, Resolution = 0.1°C ; -10 to 10°F Offset, Resolution = 0.1°F

FORMALDEHYDE SENSOR

Type

Electrochemical (Field Replaceable)

Range 0 - 1000 ppb or 0 - 1230 ug/m³

Accuracy ±10% FS@25°C

Resolution 1 (ppb, ug/m³)

Sensor Life Expectancy > 6 years

NETWORK INTERFACE

Hardware

MS/TP, 2-Wire, RS-485

Software

BACnet® or Modbus

Baud Rate

9600, 19200, 38400, 57600, 76800, or 115200

Address Range

BACnet®: 0 - 127, Modbus: 1 - 255

RELAY

Contact Rating

Form A, 2A max 24Vac/dc

Setpoint/Hysteresis/Delay

Selectable based on selected sensor

Relay Setpoints (Selectable)

PM Mass Concentration: 50 - 900 ug/ m³;

VOC: 100 - 500 VOC Index;

CH₂O: 50 - 900 ppb;

CO₂: 500 - 9000 ppm

Humidity: 20 - 90%;

Temperature: 5 - 40°C / 40 - 100°F

Relay Configuration

Via BACnet®/Modbus

Switching Power

60W, 62.5VA

VISUAL INDICATION

Display

3.5" full colour graphic LCD

User Interface

Capacitive Touchscreen

Display Options

Viewable or Concealed

Display Parameters

Temperature and Humidity - Standard

CO₂, VOC, PM & CH₂O - Selectable On/Off

Status Bars

Green/Yellow/Red - Selectable On/Off

Status LED

Green/Yellow/Red - Selectable On/Off

GENERAL

Power Supply

12 - 28 Vac/Vdc

Wiring Termination

Backplate mounted terminal block (14 to 22 AWG)

Consumption

Maximum 150mA @ 12Vdc, 1.8W

Operating Conditions

0 to 60°C (32 to 140°F), 0 to 95 %RH non-condensing

Sensor Coverage

100 m² (1000 ft²) typical

Certifications CE

ENCLOSURE

Material

White PC/ABS, UL94-V0, UV Protected

Connection

Wall plate with screw terminal blocks

Dimensions

124.5 mm H x 94.5 mm W x 29 mm D (4.9" x 3.72" x 1.14")