

INTRODUCTION

The remote network humidity/temperature sensor uses a highly accurate and reliable Thermoset Polymer based capacitance humidity sensor and curve-matched NTC thermistor temperature sensor together with state-of-the-art digital linearization and temperature compensated circuitry to monitor humidity and temperature levels and transmit values via Modbus communication to a building automation system. A hinged, gasketed weatherproof ABS enclosure provides ease of installation and protection from the elements.

BEFORE INSTALLATION

Read these instructions carefully before installing and commissioning the humidity/temperature sensor. Failure to follow these instructions may result in product damage. Do not use in an explosive or hazardous environment, with combustible or

flammable gases, as a safety or emergency stop device or in any other application where failure of the product could result in personal injury. **Follow electrostatic discharge precautions during installation and do not exceed the device ratings.**

MOUNTING

Select suitable mounting locations for the transmitter and sensor. Avoid areas where the sensor is exposed to vibrations.

A connection hole for 1/2" conduit is provided. If conduit is used, seal the opening.

The humidity/temperature sensor mounts using the two integrated mounting holes provided on the enclosure. Select the best mounting based on the wall material. The two mounting holes facilitate a #10 size screw (not supplied). The sensor probe must be pointing down. See Figure 1.

The humidity/temperature remote transmitter mounts using the two integrated mounting holes provided on the enclosure. Select the best mounting based on the wall material. The two mounting holes will facilitate a #10 size screw (not supplied). If the sensor-to-transmitter cable must be disconnected from the transmitter, ensure it is reconnected following the color code on the PCB.

Make wiring connections as per the "Wiring" illustrations.

Swing door closed until securely latched. For added security, 2 screws are provided that may be installed in the integrated screw tabs. See Figure 4.

Figure 1

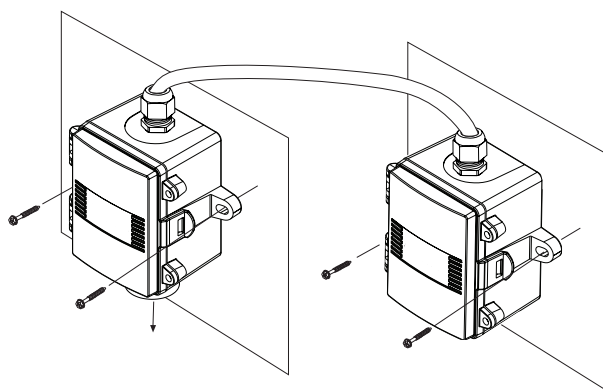

Figure 2

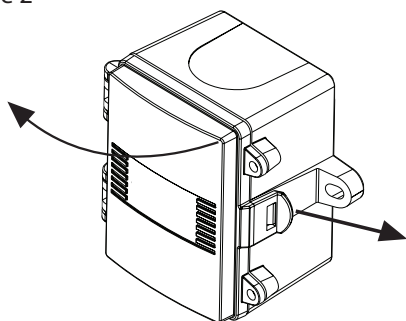
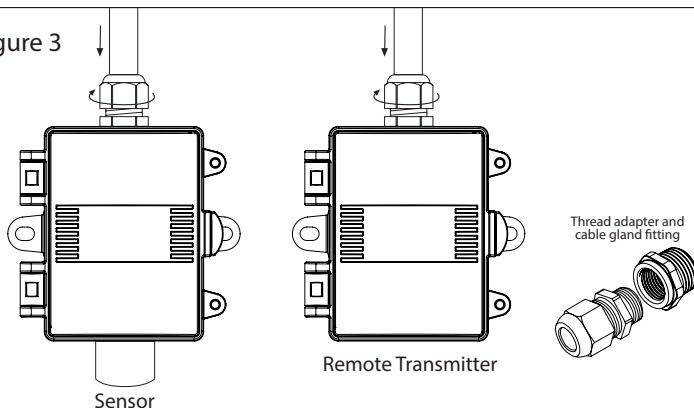

Figure 3



WIRING

Deactivate the 24 Vac/dc power supply until all connections are made to the device to prevent electrical shock or equipment damage. Follow proper electrostatic discharge (ESD) handling procedures when installing the device or equipment damage may occur. Use 22 AWG shielded wiring for all connections and do not locate the device wires in the same conduit with wiring used to supply inductive loads such as motors. Make all connections in accordance with national and local codes.

Figure 4

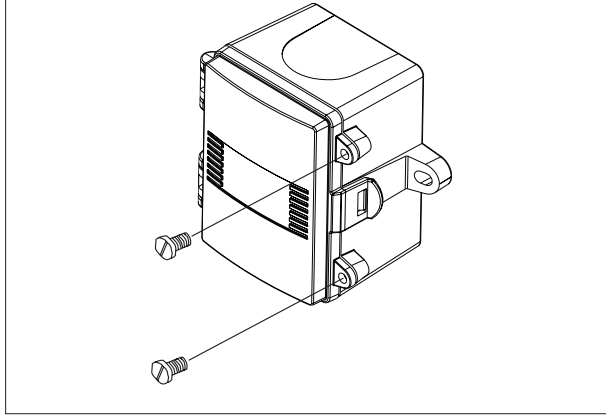

Connect the 24 Vac/dc power supply to the terminals labeled PWR (power) and COM (common) as shown in Figure 5. This device has a half-wave type power supply so use caution when wiring multiple devices so that the circuit ground point is the same on all devices and the controller. Use caution if the 24 Vac power is used and one side of the transformer is earth ground when using devices with RS-485 network connections. The device is reverse voltage protected and will not operate if connected backwards.

Connect the RS-485 network with twisted shielded pair to the terminals marked A-, B+, and SHLD (shield) as shown in Figure 5. The positive wire connects to the B(+) and the negative wire connects to A(-) and the cable shield must be connected to the SHLD terminal on each device. If the device is installed at either end of the network, an end-of-line (EOL) termination resistor (121Ω) should be installed in parallel to the A(-) and B(+) terminals. This device includes a network termination jumper and will connect the resistor correctly on the PCB. Simply move the PCB jumper to the EOL position and no external resistor is required as shown in Figure 5. The ground wire of the shielded pair should be connected to earth ground at the end of the network and the master is not grounded. DO not run a bus wiring in the same conduit as line voltage wiring.

A network segment is a single shielded wire loop run between several devices (nodes) in a daisy chain

Figure 5

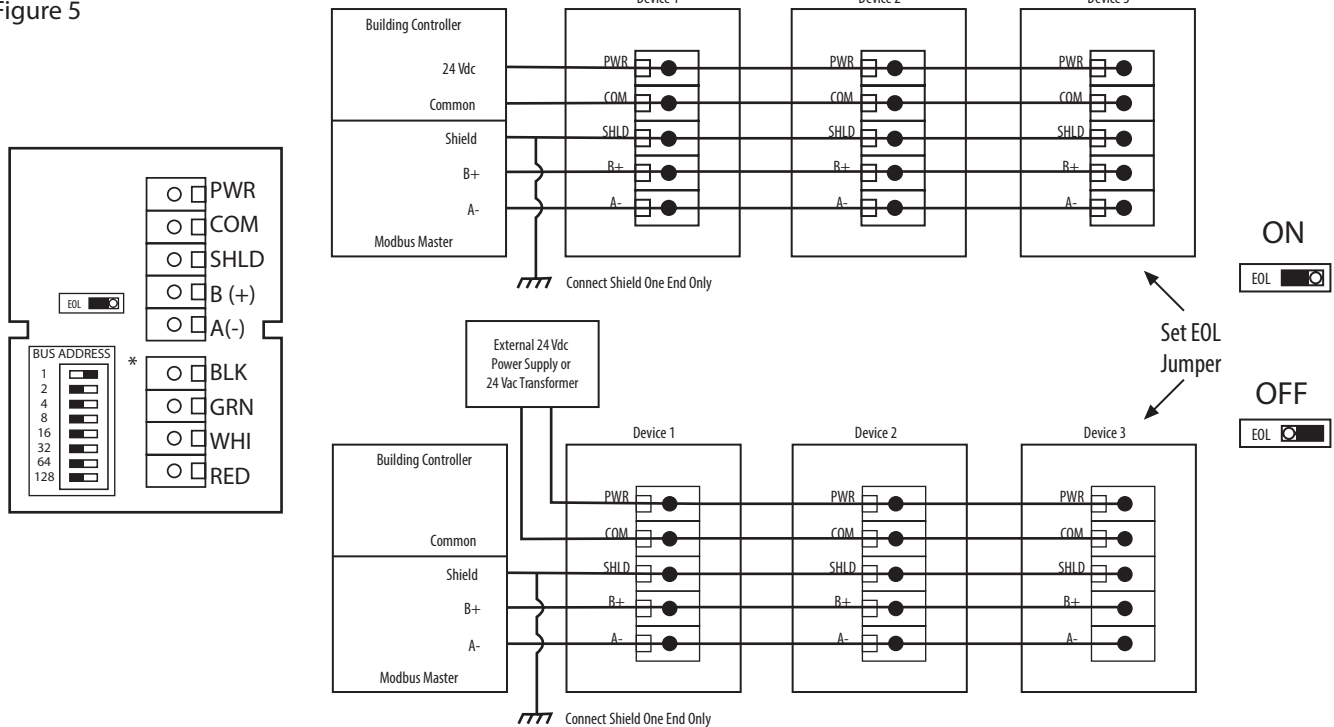

* Connect the black wire into the terminal block labeled BLK.
 Connect the green wire into the terminal block labeled GRN.
 Connect the white wire into the terminal block labeled WHI.
 Connect the red wire into the terminal block labeled RED.

configuration. The total segment length should be less than 1220 meters (4000 feet) and the maximum number of nodes on one segment is 127. Nodes are any device connected to the loop and include controllers, repeaters and sensor such as the RH/T sensor but does not include the EOL terminators. To install more devices, or to increase the network length, repeaters will be required for proper communication. The maximum daisy chain length (segment) depends on transmission speed (baud rate), wire size and number of nodes. If communication is slow or unreliable, it may be necessary to wire two daisy hains to the controller with a repeater for each segment.

NETWORK COMMUNICATION

The device parameters must be set before connection to the network and will ensure that each device has a unique Modbus address. The local DIP switch is used to set the Modbus address (1-255) as shown in Figure 6.

The factory default network configuration is:

- Baud Rate: Auto Baud Rate Detection (4800, 9600, 19200, 38400, or 76800)
- Parity: None
- Stop Bits: 1
- CRC: A001 (CRC-16 reverse)
- Delay: 0 (minimum)

Note that the Modbus network configuration may be customized at the factory if required. For example, the parity and stop bit parameters may be factory configured to suit specific applications.

The humidity/temperature sensor operates as a slave. It will not communicate unless a master is connected to the network and sends a request for information, then the slave will answer. If the device does not communicate properly, first check that the communication wires are not reversed. Then check that the slave address has a unique setting for the network segment it is connected to. Finally, verify that the device baud rate, parity bit, stop bit and RTU mode CRC polynomial are correct for the network it is connected to.

Figure 6

DIP Switch Position								Modbus Address
128	64	32	16	8	4	2	1	
OFF	OFF	OFF	OFF	OFF	OFF	OFF	ON	1
OFF	OFF	OFF	OFF	OFF	OFF	ON	OFF	2
OFF	OFF	OFF	OFF	OFF	OFF	ON	ON	3
OFF	OFF	OFF	OFF	OFF	ON	OFF	OFF	4
↓	↓	↓	↓	↓	↓	↓	↓	↓
ON	ON	ON	ON	ON	ON	ON	OFF	254
ON	ON	ON	ON	ON	ON	ON	ON	255

1

2

4

8

16

32

64

128

OFF ON

MODBUS PROTOCOL

This section describes the implementation of the Modbus protocol. It is intended to assist control system programmers who may need to add support to their systems to communicate with this device. The device communicates on standard Modbus networks using RTU mode transmission. It operates as a slave device (address from 1 to 255) and expects a Modbus master device to transmit queries, which it will answer.

RTU MESSAGE FORMAT

Modbus Framing	8 bit binary
Data Bits	start bits --- 1 data bits --- 8 parity bits --- none stop bits --- 1
Baud Rate	Auto Baud Rate Detection (4800, 9600, 19200, 38400, or 76800)
Duplex	Half duplex
Error Checking	Cyclical Redundancy Check (CRC) CRC-16 Reversed --- polynomial $x^{16}+x^{15}+x^2+x^0$ (0xA001)
Latency	More than 3.5 characters --- minimum

RTU FRAMING SUPPORT AND BIT SEQUENCES

Start	1	2	3	4	5	6	7	8	Stop
-------	---	---	---	---	---	---	---	---	------

MODBUS REGISTER ADDRESSING

Modbus Address	Typical Offset	Units	Data Type	Access	Notes
40001	+0	°C/°F	Word	Read	16-bit integer, TEMPERATURE_VALUE x 10 Multiplier = 10 -400 to 1000 for -40.0 to 100.0°C, -400 to 2120 for -40.0 to 212.0°F
40002	+1	%RH	Word	Read	16-bit integer, RELATIVE_HUMIDITY_VALUE Multiplier = 10 0 to 1000 for 0.0 to 100.0 %RH
40003	+2	°C/°F	Word	Read/Write	16-bit integer TEMPERATURE_OFFSET= -10 to 10 C_OFFSET = TEMPERATURE_OFFSET / 2 = -5.0 to 5.0°C F_OFFSET = TEMPERATURE_OFFSET = -10 to 10°F
40004	+3	%RH	Word	Read/Write	16-bit integer, RH_OFFSET = -10 to 10 RH_OFF = RH_OFFSET = -10 to 10 %RH
40005	+4		Word	Read/Write	16-bit integer, TEMPERATURE_UNITS 0 = °C, 1 = °F

RTU FUNCTION CODES

0x03 --- Read holding registers

Query

Slave address (0x01 to 0xFF)	Function code (0x03)	Starting address MSB	Starting address LSB	Quantity of Registers MSB	Quantity of Registers LSB	CRC LSB	CRC MSB
------------------------------	----------------------	----------------------	----------------------	---------------------------	---------------------------	---------	---------

*Starting address = 0x0000 to 0xFFFF, Quantity of registers = 0x0001 to 0x0005

Response

Slave address (0x01 to 0xFF)	Function code (0x03)	Byte count 2N	Register value MSB	Register value LSB	...	CRC LSB	CRC MSB
------------------------------	----------------------	---------------	--------------------	--------------------	-----	---------	---------

*N = Quantity of registers

0x06 --- Write single register

Query

Slave address (0x01 to 0xFF)	Function code 0x06	Register address MSB	Register address LSB	Register value MSB	Register value LSB	CRC LSB	CRC MSB
------------------------------	--------------------	----------------------	----------------------	--------------------	--------------------	---------	---------

Response

Slave address (0x01 to 0xFF)	Function code 0x06	Register address MSB	Register address LSB	Register value MSB	Register value LSB	CRC LSB	CRC MSB
------------------------------	--------------------	----------------------	----------------------	--------------------	--------------------	---------	---------

*Register address = 0x0000 to 0xFFFF, Registers value = 0x0000 to 0xFFFF

Exception Response

Slave address (0x01 to 0xFF)	Function code + 0x80	Exception code 0x01, 0x02 or 0x03	CRC LSB	CRC MSB
------------------------------	----------------------	-----------------------------------	---------	---------

*An exception response is only returned if the CRC is correct

Exception code 01 --- illegal function, 02 --- illegal address, 03 --- illegal data value

The RTU function codes supported by the RH/T sensor are shown below.

Note that the registers may be read individually or all registers may be read at the same time by changing the query as shown below.

To read the temperature value only...

0x03 --- Read TEMPERATURE_VALUE

Query

Slave address (0x01 to 0xFF)	0x03	0x00	0x00	0x00	0x01	CRC LSB	CRC MSB
------------------------------	------	------	------	------	------	---------	---------

Response

Slave address (0x01 to 0xFF)	0x03	0x02	Register value MSB	Register value LSB	CRC LSB	CRC MSB
---------------------------------	------	------	-----------------------	-----------------------	------------	------------

*Register value = 0xFE70 to 0x003E8, corresponding to -40.0 to 100.0°C (multiplier = 10)
 or = 0xFE70 to 0x0848, corresponding to -40.0 to 212.0°F (multiplier = 10)

The temperature value is either in °C (default) or °F depending on the value of the TEMPERATURE_UNITS register.

This register has a multiplier of 10, the application must divide by 10 to obtain the correct value.

To read the RH value only...

0x03 --- Read RELATIVE_HUMIDITY_VALUE

Query

Slave address (0x01 to 0xFF)	0x03	0x00	0x01	0x00	0x01	CRC LSB	CRC MSB
---------------------------------	------	------	------	------	------	------------	------------

Response

Slave address (0x01 to 0xFF)	0x03	0x02	Register value MSB	Register value LSB	CRC LSB	CRC MSB
---------------------------------	------	------	-----------------------	-----------------------	------------	------------

*Register value = 0x0000 to 0x03E8, corresponding to 0 to 100 %RH (multiplier = 10)

This register has a multiplier of 10, the application must divide by 10 to obtain the correct value.

To read all the registers with one query...

0x03 --- Read ALL REGISTERS

Query

Slave address (0x01 to 0xFF)	0x03	0x00	0x00 (Note 1)	0x00	0x05 (Note 2)	CRC LSB	CRC MSB
---------------------------------	------	------	------------------	------	------------------	------------	------------

Response

Slave address (0x01 to 0xFF)	0x03	0x0A (Note 3)	Register Value MSB	Register value LSB	...	CRC LSB	CRC MSB
---------------------------------	------	------------------	-----------------------	-----------------------	-----	------------	------------

Note 1: The starting address (A) may be 0x0000 to 0x0004. The read multiple feature will read all registers from the starting address forward. If the starting address is 0x0000 then registers 40001 to 40005 can be read. If the starting address is 0x0002 then the registers 40003 to 40005 can be read.

Note 2: The quantity of registers (N) may be 0x0001 to 0x0005, but must be limited to 5 - A. If the starting address (A) is set to 0x0000 the N may be 0x0001 to 0x0005. If the starting address is set to 0x0001 then the N may be 0x0001 to 0x0004.

Note 3: The byte count (B) will always be 2N. If the registers (N) is 0x0001 then B will be 0x02. If N is 0x0005 then B will be 0x0A.

0x06 --- Write TEMPERATURE_OFFSET

Query

Slave address (0x01 to 0xFF)	0x06	0x00	0x02	Register value MSB	Register value LSB	CRC LSB	CRC MSB
---------------------------------	------	------	------	-----------------------	-----------------------	------------	------------

Response

Slave address (0x01 to 0xFF)	0x06	0x00	0x02	Register value MSB	Register value LSB	CRC LSB	CRC MSB
---------------------------------	------	------	------	-----------------------	-----------------------	------------	------------

*This register is used to add or subtract an offset to the temperature value if necessary to conform to a local reference.

Register value = 0xFFF6 to 0x000A for -10 to 10

For °C operation, this corresponds to T_OFFSET / 2 = -5.0 to 5.0°C. ie: 0x0003 => 3/2 = +1.5°C offset.

For °F operation, this corresponds to T_OFFSET = -10 to 10°F. ie: 0x0003 => +3°C offset.

The operating temperature units (°C or °F) for the device should be selected first, then add any offset if necessary.

0x06 --- Write RH_OFFSET

Query

Slave address (0x01 to 0xFF)	0x06	0x00	0x03	Register value MSB	Register value LSB	CRC LSB	CRC MSB
---------------------------------	------	------	------	-----------------------	-----------------------	------------	------------

Response

Slave address (0x01 to 0xFF)	0x06	0x00	0x03	Register value MSB	Register value LSB	CRC LSB	CRC MSB
---------------------------------	------	------	------	-----------------------	-----------------------	------------	------------

*This register is used to add or subtract an offset to the RH value if necessary to conform to a local reference. Register value = 0xFFF6 to 0x000A for -10 to 10, corresponding to RH_OFFSET = -10 to 10 %RH
ie: 0x0003 => 3 = +3 %RH offset.

The operating temperature units (°C or °F) for the device should be selected first, then add any offset if necessary.

0x06 --- Write TEMPERATURE_UNITS

Query

Slave address (0x01 to 0xFF)	0x06	0x00	0x04	0x00	Register value LSB	CRC LSB	CRC MSB
---------------------------------	------	------	------	------	-----------------------	------------	------------

Response

Slave address (0x01 to 0xFF)	0x06	0x00	0x04	0x00	Register value LSB	CRC LSB	CRC MSB
---------------------------------	------	------	------	------	-----------------------	------------	------------

*Register value = 0x0000 = sets the device to °C operation
= 0x0001 = sets the device to °F operation

Exception Response

Slave address (0x01 to 0xFF)	Function code + 0x80	Exception code * 0x01, 0x02 or 0x03	CRC LSB	CRC MSB
---------------------------------	-------------------------	--	------------	------------

*An exception response is only returned if the CRC is correct
Exception code 01 --- illegal function
Exception code 02 --- illegal address
Exception code 03 --- illegal data value

DIMENSIONS

Sensor

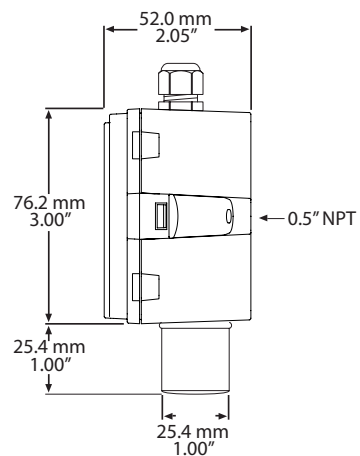
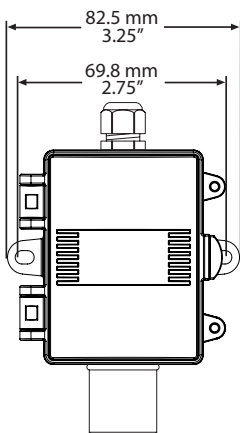

Remote Transmitter

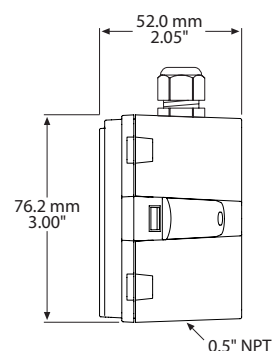
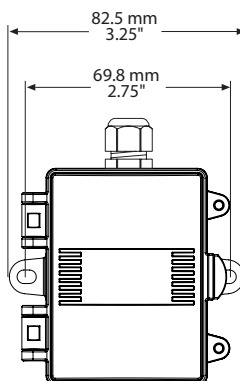

SPECIFICATIONS

TEMPERATURE SENSOR

Temperature Sensor 20 K Ω NTC thermistor
Sensor Accuracy..... $\pm 0.2^{\circ}\text{C}$ ($\pm 0.4^{\circ}\text{F}$) @ 0 to 70 $^{\circ}\text{C}$ (32 to 158 $^{\circ}\text{F}$)
Probe Sensing Range -40 to 50 $^{\circ}\text{C}$ (-40 to 122 $^{\circ}\text{F}$), 5 to 95 %RH non-condensing
Resolution 0.1 $^{\circ}\text{C}/^{\circ}\text{F}$

RELATIVE HUMIDITY

Sensor Thermoset polymer based capacitive
Accuracy ± 2 RH
Range 0-100 %RH
Resolution 0.1 %RH
Hysteresis ± 1.5 %RH
Response Time 15 seconds typical
Stability ± 1.2 %RH typical @ 50 %RH in 5 years

MODBUS COMMUNICATION

Hardware 2 wire RS-485
Software Native Modbus MS/TP protocol (RTU)
Baud Rate 4800, 9600, 19200, 38400, or 76800 (auto-detect)
Address Range 1 to 255 (switch selectable)
Parity None
Stop Bits 1
Error Checking CRC-16 reverse (A001)

GENERAL

Power Supply 15 - 30 Vac/dc (non-isolated half-wave rectified)
Consumption 10 mA max @ 24 Vdc
Protection Circuitry Reverse voltage protected, overvoltage protected
Operating Environment -40 to 50 $^{\circ}\text{C}$ (-40 to 122 $^{\circ}\text{F}$), 5 to 95 %RH non-condensing
Sensing Probe 20mm (0.8") long x 28mm (1.1") diameter PVC hub with mesh filter
Wire Material FT-6 plenum rated cable
Wire Length 3 m (9.8")
Wiring Connection Screw terminal block (14 to 22 AWG)
Enclosure ABS, UL94-V0, IP65 (NEMA 4X)
Dimensions 82.5mm W x 76.2mm H x 52.0mm D (3.25" x 3.0" x 2.05")
Country of Origin Canada