

Introduction

The outside temperature transmitter uses a highly accurate and reliable platinum RTD in a weatherproof enclosure to monitor outside temperature levels and provide an analog signal output. Sensors are mounted in a sun and wind shield for more accurate monitoring.

Before Installation

Read these instructions carefully before installing and commissioning the temperature transmitter. Failure to follow these instructions may result in product damage. Do not use in an explosive or hazardous environment, with combustible or flammable gases, as a safety or emergency stop device or in any other application where failure of the product could result in personal injury. Take electrostatic discharge precautions during installation and do not exceed the device ratings.

Select a suitable mounting spot on an exterior wall where the sensor is best protected from direct exposure to sunlight & wind. Preferably on a north facing wall. Avoid areas where the sensor is exposed to vibrations or rapid temperature changes.

The enclosure provides a connection hole for 1/2" Conduit. Run a length of conduit through exterior wall and seal. Use 14-22 AWG shielded wiring for all connections and do not locate the device wires in the same conduit with wiring used to supply inductive loads such as motors. Make all connections in accordance with national and local codes.

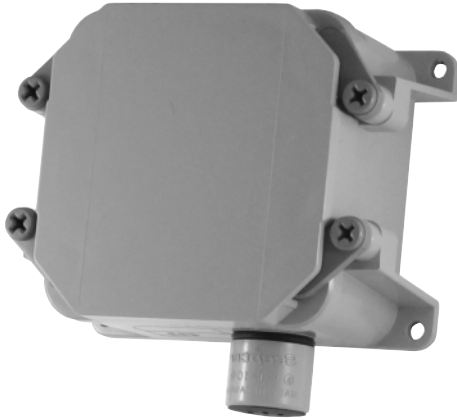

Mounting

The sensor installs directly on an exterior wall using the four integrated mounting holes provided on the enclosure. The four mounting holes will facilitate a #10 size screw (not supplied). The sensor fitting must be pointing down. See **Figure 1**.

The sensor cover is secured with 4 rotating latches. Remove the cover by rotating the latch using a Phillips screwdriver. See **Figure 2**.

Feed the conduit or cable gland fitting through the provided hole in bottom of enclosure as show in **Figure 3**. It is recommended that weatherproof conduit or cable gland fittings be used.

Make wiring connections as per the "Wiring" illustrations on Page 2.

Replace cover and secure with the 4 rotating latches.

Figure 1

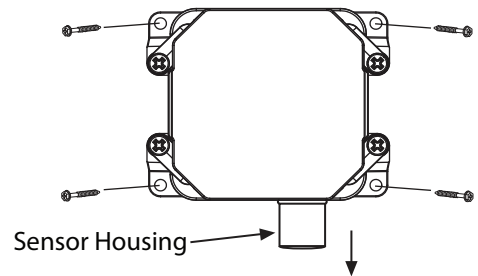

Figure 2

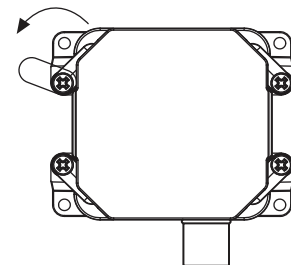
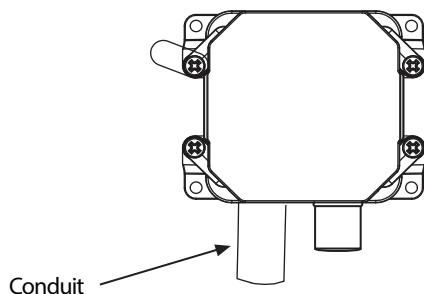

Figure 3



Wiring

- Deactivate the 24 Vac/dc power supply until all connections are made to the device to prevent electrical shock or equipment damage.
- Use 14-22 AWG shielded wiring for all connections and do not locate the device wires in the same conduit with wiring used to supply inductive loads such as motors. Make all connections in accordance with national and local codes.
- The temperature transmitter comes with the temperature sensor pre-wired to the transmitter board. If removal is required for installation then it may be re-wired as shown in **Figure 4**.
- Pull at least six inches of control wire into the enclosure, then complete the wiring connection according to the wire diagram for the applicable power supply and output signal type as shown in **Figure 5**.
- Connect the DC positive or the AC voltage hot side to the PWR terminal. For voltage output or AC power, the supply Common is connected to the COM terminal. The device is reverse voltage protected and will not operate if connected backwards. It has a half-wave power supply so the supply Common is the same as the signal Common. See **Figure 5**.
- The analog output is available on the OUT terminal. Check the controller Analog Input to determine the proper connection before applying power as shown in **Figure 5**.
- Once all connections are made and checked, power can be applied.

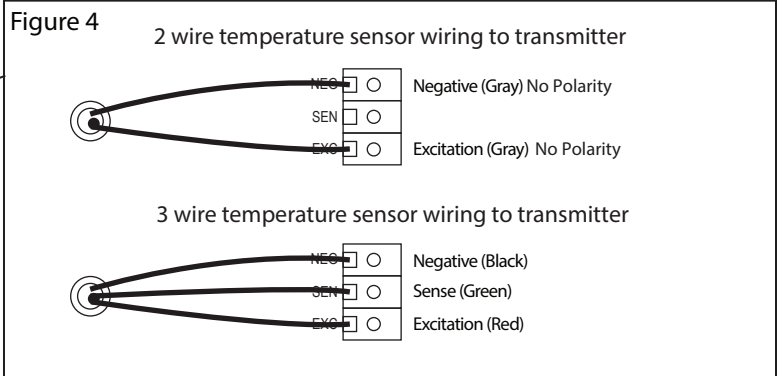
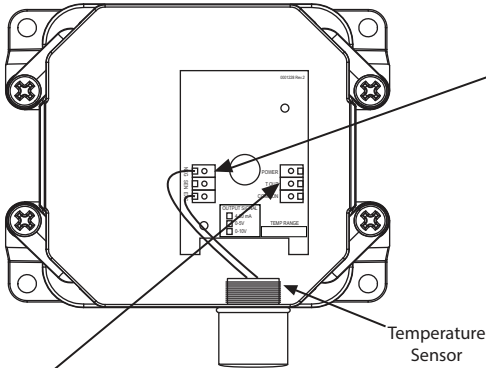
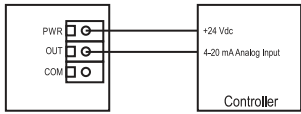

Figure 5

Transmitter Wiring to Controller

Wiring for 4-20 mA loop-powered output and 24 Vdc power from controller



Wiring for 4-20 mA loop-powered output and external 24 Vdc power supply

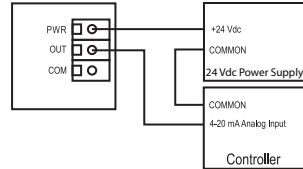

Wiring for 0-5 or 0-10 Vdc output signal and 24 Vdc power from controller

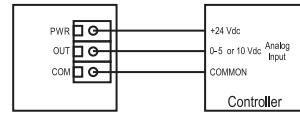

Wiring for 0-5 or 0-10 Vdc output signal and with external 24 Vdc power supply

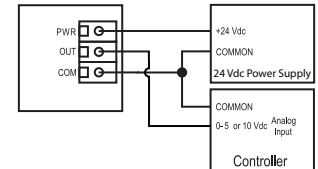

Wiring for all output signals with external 24 Vac power transformer

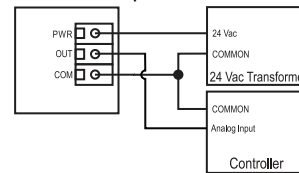

Specification:

Sensor.....	1000 ohm Platinum RTD
Accuracy.....	RTD Class A: $\pm 0.15^{\circ}\text{C}$ @ 0°C RTD 1/3 DIN: $\pm 0.1^{\circ}\text{C}$ @ 0°C RTD 1/10 DIN: $\pm 0.03^{\circ}\text{C}$ @ 0°C
Probe Sensing Range.....	-40 to 85°C (-40 to 185°F)
Wire Material.....	PVC insulated, parallel bonded
Output Signal.....	4-20mA current loop, 0-5 Vdc, or 0-10 Vdc (factory configured)
Transmitter Accuracy.....	$\pm 0.25\%$ of span, including linearity
4-20 mA loop power Supply.....	15-35 Vdc or 22-32 Vac
Minimum Current Loop.....	2 mA nominal (occurs with shorted sensor)
Maximum loop Current.....	22.5 mA nominal (occurs with open sensor)
Maximum Loop Load.....	>600 ohms
0-5 Vdc Power Supply.....	10-35 Vdc or 10-32 Vac
0-10 Vdc Power Supply.....	15-35 Vdc or 15-32 Vac
Maximum Current (Voltage).....	5 mA nominal
Maximum Output (Voltage).....	limited to 5.5 Vdc for 0-5 Vdc, 10.5 for 0-10 Vdc
Input Voltage Effect.....	Negligible over specified operating range
RFI rejection.....	Good RFI rejection of normal frequencies
Protection Circuitry.....	Reverse voltage protected and output limited
Ambient Operating Range.....	-40 - 85°C (-40 - 185°F), 0-95% RH non-condensing
Enclosure.....	PVC, IP65 (NEMA 4X)
Wiring Connections.....	Screw terminal block (14 to 22 AWG)

Dimensions:

