

Introduction

The high accuracy single point, remote probe immersion temperature sensor utilizes a precision sensor encapsulated in a 6.35 mm (0.25") OD, 304 series stainless steel probe and is available in various lengths. All probes provide excellent heat transfer, fast response and resistance to moisture penetration. A transmitter that provides a high accuracy signal with excellent long term stability, low hysteresis and fast response is available with various ranges. A round ABS enclosure with a twist off cover is provided for ease of installation.

Before Installation

Read these instructions carefully before installing and commissioning the temperature thermostat. Failure to follow these instructions may result in product damage. Do not use in an explosive or hazardous environment, with combustible or flammable gases, as a safety or emergency stop device or in any other application where failure of the product could result in personal injury. **Take electrostatic discharge precautions during installation and do not exceed the device ratings.**

Mounting (Probe)

The remote probe immersion sensor must be installed into a thermowell. Failure to use a thermowell will create leaks and could damage the sensor. The sensor is provided in two pieces, probe assembly and enclosure, which allows for easier installation. The probe assembly has 1/2" NPT threaded fitting for mounting to the thermowell. Install the thermowell as recommended in Figure 1. For complete thermowell installation instructions, please refer to installation instructions provided with the thermowell.

It is recommended to use heat conductive compound. Prior to installing the sensor inject a liberal amount into the thermowell and/or on the tip of the sensor. Slide the probe into thermowell until the fitting makes contact with the thermowell. Tighten slightly by hand by turning clockwise. Using a 23 mm (7/8") wrench, tighten the fitting into the thermowell until snug. To protect against over-tightening and damaging the probe, the assembly is designed to allow the probe to slide inside the fitting. See Figure 2.

Mounting (Enclosure)

Mount the enclosure on a flat surface in close proximity to the area where the probe inserted in the pipe. Secure the enclosure with (2) #10 x 25 mm (1") self tapping screws (not provided). Remove cover by grasping and twisting approximately a quarter turn counter-clockwise. Remove cover and set aside for re-installing after wiring and set up.

Insert the probe assembly wire through the cable gland connector pulling about 150 mm (6") inside the enclosure. Tighten the cable gland connector using a 15 mm wrench until snug. As shown in Figure 4.

It is recommended in chilled water applications that the excess cable be coiled and hung so that it is lower than the pipe and the enclosure. This will prevent any condensation to run into the probe assembly or enclosure. See Figure 5.

A 21 mm (0.8125") hole provided for connection to a 12.77mm (0.5") EMT or cable gland style connector. Insert the EMT or cable gland connector through the hole and securely fasten using a locknut as shown in Figure 6.

Make wire connections as per the "Wiring" illustrations on Page 2.

Once wiring and set up are complete, re-install cover.

Figure 1

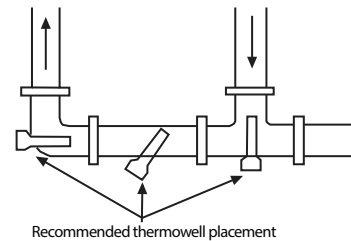

Figure 2

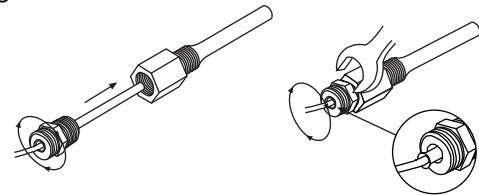

Figure 3

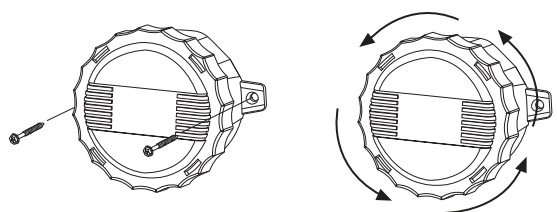

Figure 4

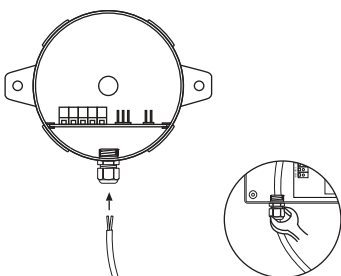

Figure 5

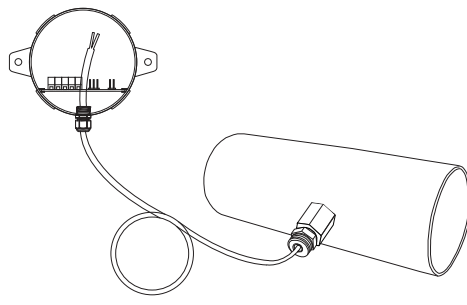
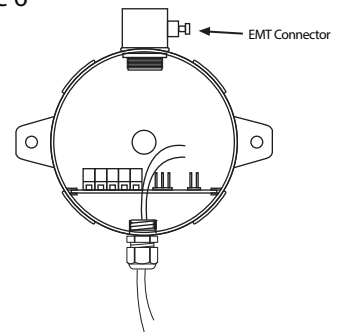
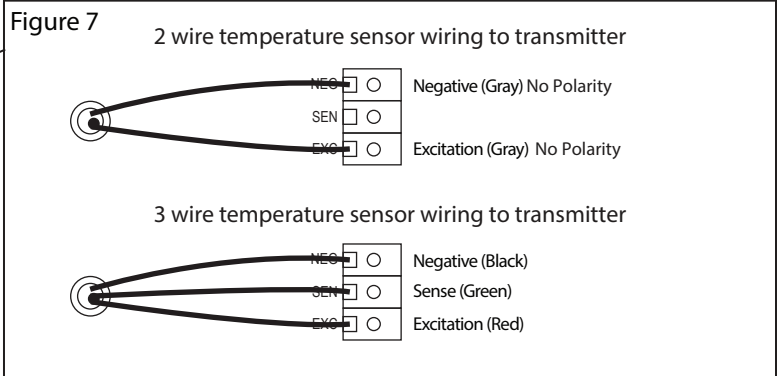
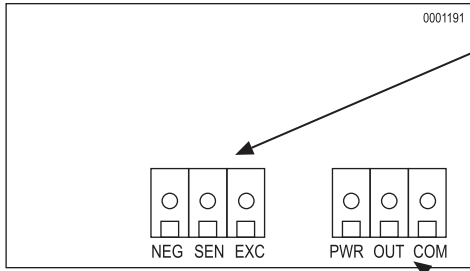

Figure 6



Wiring

- Deactivate the 24 Vac/dc power supply until all connections are made to the device to prevent electrical shock or equipment damage.
- Connect the temperature sensor to the transmitter as shown in Figure 7.
- Use 14-22 AWG shielded wiring for all connections and do not locate the device wires in the same conduit with wiring used to supply inductive loads such as motors. Make all connections in accordance with national and local codes.
- Pull at least six inches of control wire into the enclosure, then complete the wiring connection according to the wire diagram for the applicable power supply and output signal type as shown in Figure 8.
- Connect the DC positive or the AC voltage hot side to the PWR terminal. For voltage output or AC power, the supply Common is connected to the COM terminal. The device is reverse voltage protected and will not operate if connected backwards. It has a half-wave power supply so the supply Common is the same as the signal Common. See Figure 8.
- The analog output is available on the OUT terminal. Check the controller Analog Input to determine the proper connection before applying power as shown in Figure 8.
- Once all connections are made and checked, power can be applied.



Input Voltage Effect	Negligible over specified
Specification:	
Sensor.....	1000 ohm Platinum RTD
Probe Sensing Range	-20 to 105°C (-4 to 140°F)
Wire Material.....	2 wire: PVC insulated, parallel bonded 3 wire: FT-4
Probe Material.....	304 Series Stainless Steel
Probe Dimensions.....	0.25" (6.35 mm) Diameter Standard lengths: 50, 100, 150, 200 mm (2', 4', 6', 8')
Fitting.....	1/2" NPT Brass w/ spring-loaded probe
Output Signal	4-20mA current loop, 0-5 vdc, or 0-10 Vdc (factory configured)
Transmitter Accuracy	±0.1% of span, including linearity
4-20 mA loop power Supply ...	15-35 Vdc or 22-32 Vac
Minimum Current Loop	2 mA nominal (occurs with shorted sensor)
Maximum loop Current	22.5 mA nominal (occurs with open sensor)
Maximum Loop Load	>600 ohms
0-5 Vdc Power Supply	10-35 vdc or 10-32 Vac
0-10 Vdc Power Supply	15-35 Vdc or 15-32 Vac
Maximum Current (Voltage) ...	5 mA nominal
Maximum Output (Voltage)	Limited to <5.5 Vdc for 0-5 Vdc, <10.5 Vdc for 0-10 Vdc
Input Voltage Effect	Negligible over specified operating range
RFI rejection	Good RFI rejection of normal frequencies
Protection Circuitry	Reverse voltage protected and output limited
Ambient Operating Range	-40 - 85°C (-40 - 185°F), 0-95% RH non-condensing
Enclosure	ABS, UL94-V0, IP65 (NEMA 4X)
Wiring Connections	Screw terminal block (14 to 22 AWG)
Country of Origin	Canada

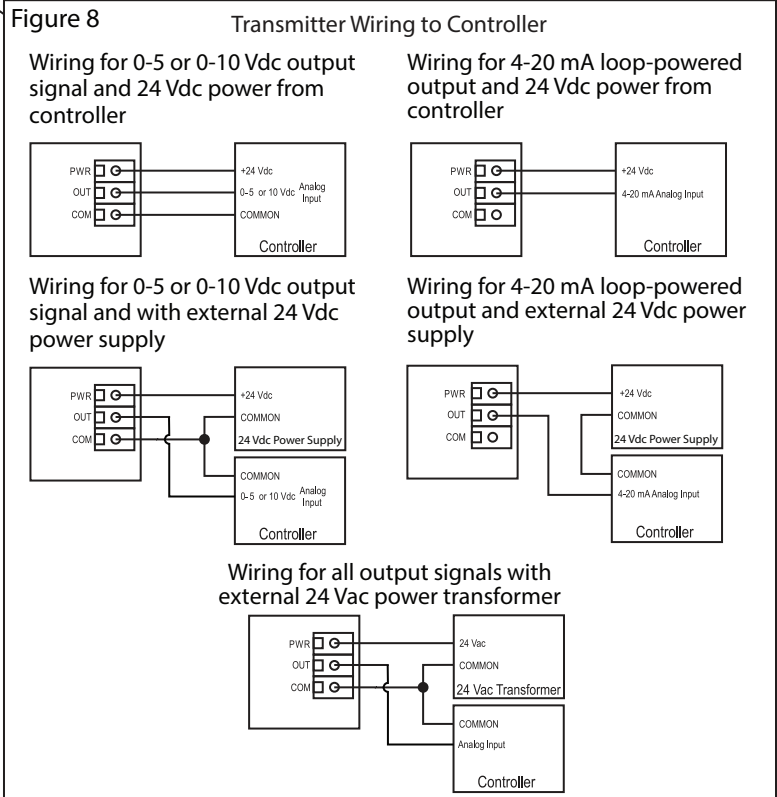

Dimensions:

