

### INTRODUCTION

The high accuracy single point duct temperature sensor utilizes a precision sensor encapsulated in a 6.35 mm (0.25") OD, 304 series stainless steel probe and is available in various lengths. All probes provide excellent heat transfer, fast response and resistance to moisture penetration. The sensor comes with an integrated mounting bracket and 3.05 m (10') of plenum rated cable for connection to the Building Automation System.

### BEFORE INSTALLATION

Read these instructions carefully before installing and commissioning the temperature sensor. Failure to follow these instructions may result in product damage. Do not use in an explosive or hazardous environment, with combustible or flammable gases, as a safety or emergency stop device or in any other application where failure of the product could result in personal injury. **Do not exceed the device ratings.**

### MOUNTING

The duct temperature sensor installs directly into any air duct with several lengths available for a wide range of duct widths/diameters. Please select a suitable installation area in the middle of the duct wall. To achieve the best reading, do not place in an area where air stratification may be present. Mount the sensor at least 1.5 m (5') in either direction from elbows, dampers, filters or other duct restrictions. Avoid areas where the sensor is exposed to vibrations or rapid temperature changes.

Once a suitable spot is selected, drill a 9.5 - 12 mm (3/8" - 1/2") hole for the probe.

Slide the probe in the drilled hole until the bracket is flush against the duct. The airflow direction is not important. Secure the bracket to the duct with (2) #10 x 25 mm (1") self tapping screws (not provided). Tighten screws until the bracket is tight against the duct and ensure there is no movement of the bracket as shown in Figure 1.

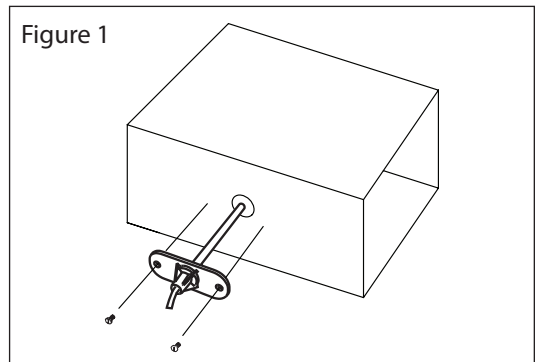

Once installed, complete wiring the wiring instructions below.

**Figure 2 2 Wire Termination for Thermistor**

**Figure 3 3 Wire Termination for RTD**

### SPECIFICATIONS

Sensor Type .....	Various Thermistor or RTD
Probe Sensing Range .....	-20 to 60°C (-4 to 140°F)
Sensor Accuracy .....	<b>RTD Class A:</b> ±0.15°C (±0.27°F) @ 0°C (32°F)
	<b>RTD 1/3 DIN:</b> ±0.1°C (±0.18°F) @ 0°C (32°F)
	<b>RTD 1/10 DIN:</b> ±0.03°C (±0.054°F) @ 0°C (32°F)
	<b>NTC Thermistor Type 39:</b> ±0.05°C (±0.09°F), 0 to 70°C (32 to 158°F)
	<b>NTC Thermistor Type 55:</b> ±0.03°C (±0.054°F), 0 to 70°C (32 to 158°F)
	<b>NTC Thermistor Type 40/46:</b> ±0.1°C (±0.18°F), 0 to 70°C (32 to 158°F)
Wire Material .....	Plenum rated FT-6
Wire Length .....	3.05 m (10')
Probe Material .....	304 series stainless steel
Probe Diameter .....	6.35 mm (0.25")
Bracket Material .....	ABS, UL94-5VB
Termination .....	Pigtail 2 or 3 wire
Country of Origin .....	Canada

**NOTE:** The sensor accuracies listed in the specifications section apply to the sensing element only prior to product assembly and may not be reflected in the complete assembly.

Due to the measurement uncertainty, it is possible, that the true resistance value of the single delivered sensor at 0°C can be out of the defined tolerance class. Profiling each assembly to take into consideration lead wire and the attachment method should be completed.

### TYPICAL WIRE RESISTANCE VALUES

When using low resistance sensors, long wire runs can add significant error to the readings. Use the following chart to determine errors due to wire resistance or consider using a 1000 ohm sensor or a transmitter for better accuracy. Locate the type of wire being used. Multiply the total length of the wire (distance from the controller to the sensor and back) by the number found in the chart below for total resistance.

GAUGE WIRE TYPE	18 AWG	22 AWG	24 AWG
STRANDED (OHMS/FOOT)	5.85 mΩ	14.75 mΩ	23.29 mΩ
SOLID (OHMS/FOOT)	6.4 mΩ	15.85 mΩ	25.72 mΩ

### DIMENSIONS

