

#### INTRODUCTION

The high accuracy single point glass temperature transmitter utilizes a precision sensor encapsulated in a 31.75mm L x 9.525mm W x 9.525 mm H (1.25" x .375" x .375") Aluminum probe. Standard wire length is 600 mm (24"). All probes are constructed to provide excellent heat transfer, fast response, and are potted to resist moisture penetration. A transmitter that provides a high accuracy signal with excellent long term stability, low hysteresis and fast response is available with various ranges.

#### BEFORE INSTALLATION

Read these instructions carefully before installing and commissioning the temperature transmitter. Failure to follow these instructions may result in product damage. Do not use in an explosive or hazardous environment, with combustible or flammable gases, as a safety or emergency stop device or in any other application where failure of the product could result in personal injury. **Do not exceed the device ratings.**

#### MOUNTING

The glass transmitter installs directly onto any window where the enclosure can be mounted nearby. Select a suitable location on an exterior window where both the probe and the enclosure can be mounted. On one side of the probe apply epoxy compound and press firmly against the glass. See Figure 1. Use whatever means available (electrical tape will do) to secure the probe to the window while the epoxy sets. To achieve the best reading, do not place in an area where air stratification may be present. Avoid areas where the sensor is exposed to vibrations or rapid temperature changes.

Unroll the sensing cable probe, being careful not to kink the wire. The airflow direction is not important. Secure the enclosure to the wall with two #10 x 25 mm (1") self tapping screws (not provided). Tighten screws until the enclosure is tight against the wall and ensure that there is no movement of the enclosure as shown in Figure 1.

The enclosure has a hinged cover with a latch. Open the cover by pulling slightly on the latch on the right side of the enclosure, at the same time pulling on the cover, as illustrated in Figure 2.

A 1/2" NPT threaded connection hole is provided in the bottom of the enclosure. Screw the EMT connector or cable gland connector in until tight. See Figure 3. It is recommended that weatherproof conduit or cable gland fittings be used. The F style enclosure includes a 1/2" NPT to M16 thread adapter and cable gland fitting.

Make wire connections as per the "Wiring" illustrations on Page 2.

Swing door closed until securely latched. For added security, two screws are provided that may be installed in the integrated screw tabs. See Figure 4.

Figure 1

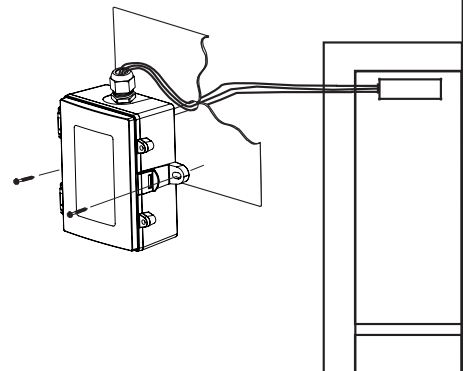

Figure 2

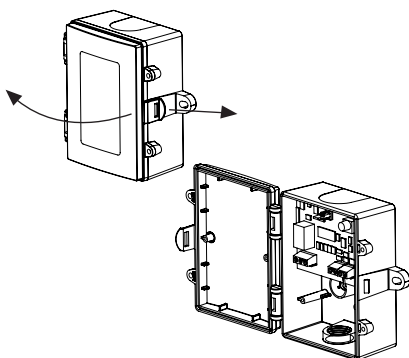

Figure 3

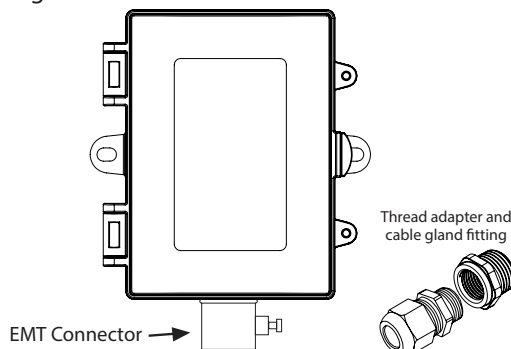

Figure 4

