

INTRODUCTION

The duct humidity transmitter uses highly accurate and reliable Thermoset Polymer based capacitance humidity sensor together with state-of-the-art digital linearization and temperature compensated circuitry to monitor humidity levels. The sensor is encapsulated in a 228.60 mm (9") long by 12.7 mm (0.5") diameter S/S probe. A 60 micron HDPE filter protects the sensor for contaminants. A weatherproof PVC enclosure is provided for electrical connections.

BEFORE INSTALLATION

Read these instructions carefully before installing and commissioning the temperature sensor. Failure to follow these instructions may result in product damage. Do not use in an explosive or hazardous environment, with combustible or flammable gases, as a safety or emergency stop device or in any other application where failure of the product could result in personal injury. **Take electrostatic discharge precautions during installation and do not exceed the device ratings.**

MOUNTING

The transmitter installs directly into any air duct with a minimum width/diameter of 25.5 cm (10"). Select a suitable installation area in the middle of the duct wall. To achieve the best reading, do not place in an area where air stratification may be present. **Mount the sensor at least 1.5 m (5') in either direction from elbows, dampers, filters or other duct restrictions. Avoid areas where the transmitter is exposed to vibrations or rapid temperature changes.**

Once a suitable spot is selected, drill a 15 -20 mm (0.6" - .75") hole for the probe.

Slide the probe in the drilled hole until the enclosure is flush against the duct. The airflow direction is not important. Secure the enclosure to the duct with (4) #10 x 25 mm (1") self tapping screws (Not provided). Tighten screws until the enclosure is tight against the duct and that there is no movement of the enclosure as shown in Figure 1.

A foam gasket on the back of the enclosure provides a tight seal against any air leaks.

The sensor cover is secured with 4 rotating latches. Remove the cover by rotating the latch using a Phillips screwdriver. See Figure 2.

Feed the conduit or cable gland fitting through the provided hole in bottom of enclosure as show in Figure 3. It is recommended that weatherproof conduit or cable gland fittings are used.

Make wiring connections as per the "Wiring" illustrations on Page 2.

Replace cover and secure with the 4 rotating latches.

Figure 1

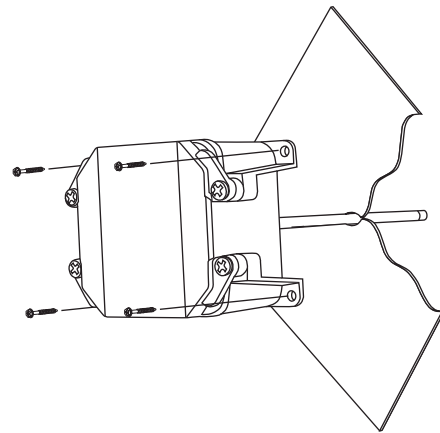

Figure 2

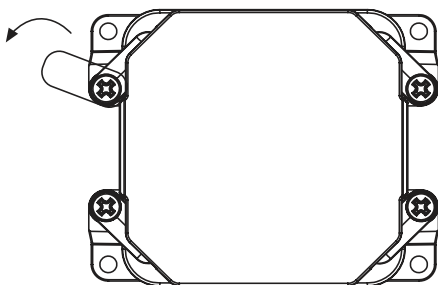
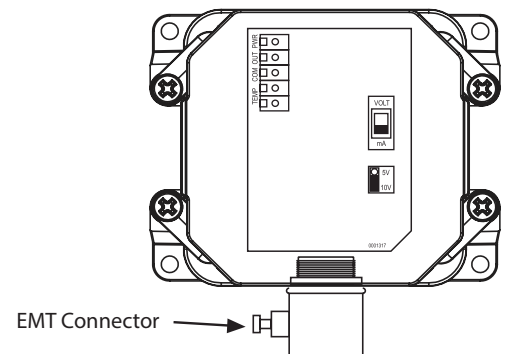
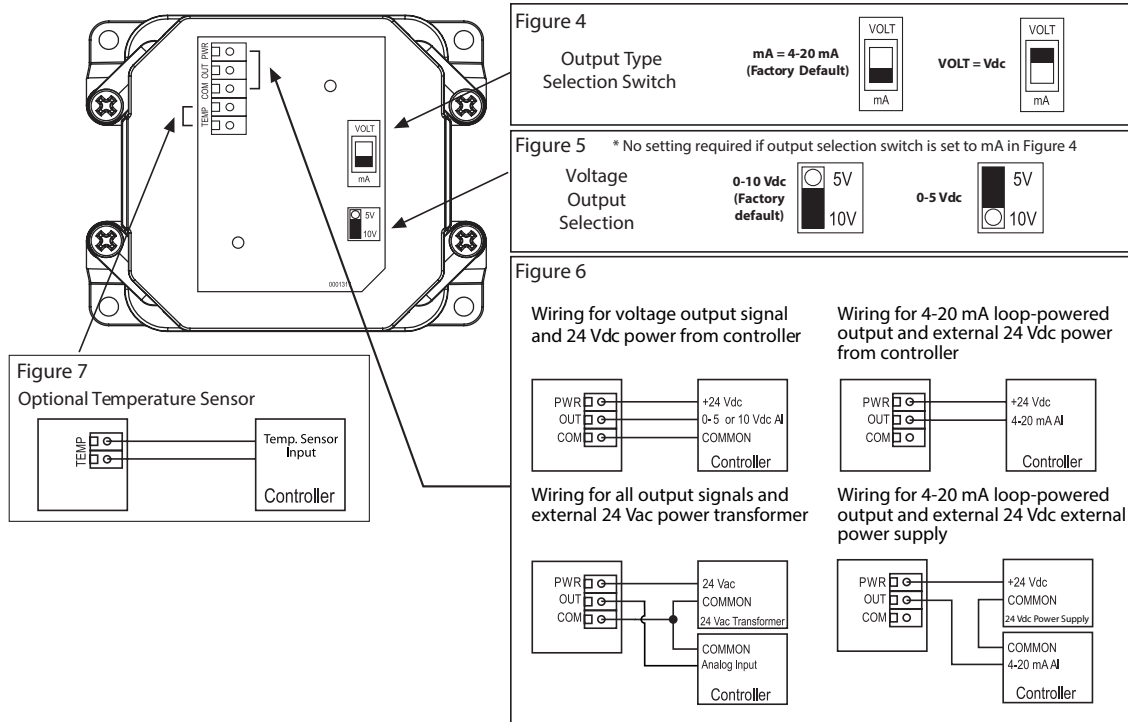

Figure 3



WIRING

- Deactivate the 24 Vac/dc power supply until all connections are made to the device to prevent electrical shock or equipment damage.
- Use 14-22 AWG shielded wiring for all connections and do not locate the device wires in the same conduit with wiring used to supply inductive loads such as motors. The humidity and temperature connections can be made using a single, multi conductor, shielded cable if desired. Make all connections in accordance with national and local codes.
- Pull at least six inches of wire into the enclosure, then complete the wiring connection according to the wire diagram for the applicable power supply and output signal type.
- Select desired signal output type (mA or Vdc) by placing the output switch in required position, as shown in Figure 4. Factory default is mA (4-20 mA).
- If mA was selected, no further Output set up is required. If VOLT output is selected in Figure 5, place Voltage Output Jumper to desired span position, as shown in Figure 5. ie: 10 = 0-10 Vdc. Factory default is 10v = 0-10Vdc.
- Connect the DC positive or the AC voltage hot side to the PWR terminal. For voltage output or AC power, the supply Common is connected to the COM terminal. The device is reverse voltage protected and will not operate if connected backwards. It has a half-wave power supply so the supply Common is the same as the signal Common. See Figure 6.
- The analog output is available on the OUT terminal. Check the controller Analog Input to determine the proper connection before applying power as shown in Figure 6.
- If installed, the resistance temperature output is available on the two terminals labelled TEMPERATURE SENSOR as shown in See Figure 7.



SPECIFICATION:

Sensor Type:.....Thermoset Polymer based Capacitive
 Range:.....0 to 100% RH
 Accuracy:.....±1 (20 to 80% RH), ±2% RH (5 to 95% RH)
 Response:.....15 Seconds typical
 Temp Dependence:.....±0.05% RH/ °C
 Hysteresis:.....±1.5% RH maximum
 Repeatability:.....±0.5% RH typical
 Linearity:.....±0.5% RH typical
 Operating Range:.....-40 to 85°C (-40 to 185°F)
 Power Supply:.....18 to 30 Vdc, 15 to 26 Vac
 Consumption:.....22 mA maximum
 Protection Circuitry:.....Reverse voltage protected and output limited
 Output Signal:.....4-20 mA current loop, 0-5 or 0-10 Vdc
 (jumper-selectable)
 Output Drive @ 24 Vdc:..550 ohms max for current output
 10K ohms min for voltage output
 Internal Adjustments:..Clearly marked ZERO and SPAN pots
 Optional Temp.:.....Various High Accuracy RTD's or Thermistors, 2 Wire
 Probe:.....230 mm (9") probe length x 12.7 mm (1/2")
 diameter stainless steel with 60 micron HDPE porous filter
 Enclosure:.....PVC, UL94 V-0, IP65 (NEMA 4)
 Termination:.....Screw terminal block (14 to 22 AWG)

DIMENSIONS

