



INSTALLATION AND MAINTENANCE INSTRUCTIONS DSD2G DUCT SMOKE DETECTORS

4-Wire, Photoelectric

PRODUCT OVERVIEW

PRODUCT APPLICATION

DSD2G Series duct smoke detectors provide early detection of smoke and products of combustion present in air moving through an HVAC duct supply, return, or both in commercial, industrial, and residential applications. These devices are designed to prevent the recirculation of smoke in areas by the air handling system's fans and blowers. Complete systems may be shut down in the event of smoke detection.

NOTE: For the correct installation of a duct smoke unit, please refer to the NFPA 72 (National Fire Alarm Code), NFPA 90A (Standard for Installation of Air Conditioning and Ventilation Systems), NFPA 92A (Recommended Practice for Smoke Control Systems.), NFPA 5000 (Building Construction and Safety Code), IMC (International Mechanical Code), and IFC (International Fire Code).

This detector is not intended for open area protection nor should it be used for early warning detection or replace a regular fire detection system.

PRODUCT DESCRIPTION

The DSD2G Series smoke detector is fitted with a mounting base that will accept a photoelectric smoke detector head model 55000-328APO. The duct unit supports two sets of form "C" alarm contacts, one form "A" alarm contact and one form "C" trouble contact. The trouble contact supervises the presence of the input power, removal of the detector cover and the removal of the smoke detector head.

This detector is equipped with a cover removal switch that instantly provides a trouble condition upon removal of the clear cover. For all testing and inspection with the cover removed, the cover removal switch (designated as SW1 on PCB) must be manually depressed to simulate standard "pilot" operation. THE TROUBLE CONTACTS (TERMINALS 4, 15, 5) ARE SHOWN IN THE NON-ENERGIZED CONDITION.

The trouble contacts **will not** operate in the event of a smoke alarm. The DSD2G Series duct detector will operate from various input voltage sources; namely 24VAC, 24VDC, 115VAC and 230VAC.

SAMPLING TUBES

The operating principle of a duct detector is based on the Venturi effect. Two tubes extend into the HVAC duct. Air flowing through the duct is forced into the air intake (inlet) tube via the air intake holes, (facing the airflow) and passes over the detector head. The air will be drawn out via the exhaust tube back into the HVAC duct. (A 7" exhaust tube is provided in the installation kit.) When the concentration of smoke particles suspended in the air stream reach the alarm threshold of the detector head, the unit will go into alarm.

The duct smoke detector units are designed to operate in duct widths from 6" to 10' wide with an air velocity between 100 to 4,000 feet per minute. To verify correct installation, the pressure differential between the sampling (high side) and exhaust (low side) tubes should be measured using a Magnehelic pressure gauge or equivalent. An acceptable reading is between 0.01 and 1.2 inches of water.

To minimize the impact of air turbulence and stratification on performance, a duct smoke detector should be located as far as possible downstream from any obstruction (i.e. deflector plates, elbows, dampers, etc.). In all situations, confirmation of velocity and pressure differential within specifications is required.

REMOTE ACCESSORIES

Audible and visual alarm indicators, remote status indicators, and remote reset/test switches can be accommodated by the DSD2G Series duct units by connecting to DC voltage output terminals as described on Page 4. These terminals are not supervised and the voltage/current will only be present when the detector unit is in alarm. The remote pilot (green) LED will be permanently illuminated when connected to the output terminals as long as input power and detector head are present.

DSD2G AT-A-GLANCE

MODEL NUMBER:

DSD2G 4-Wire Photoelectric Duct Smoke Detector

DETECTOR HEAD MODEL NUMBER:

Photoelectric Detector Head: 55000-328APO

RELAY CONTACT RATINGS:

POWER	STANDBY CURRENT		ALARM CURRENT	
		WITH ACCESSORIES		WITH ACCESSORIES
24VAC	55.0mA	95.0mA	190.0mA	280.0mA
24VDC	14.0mA	32.0mA	68.0mA	165.0mA
115VAC	22.0mA	25.0mA	32.0mA	50mA
230VAC	14.0mA	14.0mA	18.0mA	30.0mA

Alarm contacts: 2 Sets form "C" rated at 10A @ 115VAC resistive
1 form "A" rated at 2A

Trouble contacts: 1 Set form "C" rated at 10A @ 115VAC resistive

Air velocity: 100 to 4,000ft/min.

Ambient temperature: 32°F to 140°F (0°C to 60°C)

Humidity: 10% to 85% RH Non-Condensing/Non-Freezing

Material: Gray plastic back box with clear plastic cover (Makrolon 94V-0)

Dimensions: 13½" L X 4½" W X 2¼" D

Max. net wt.: 3½ lbs.

Do not expose to corrosive atmospheres.

U.S. Patents 6,741,181; 7,204,522; 6.124.795

MECHANICAL INSTALLATION

LOCATION PREREQUISITES

This guideline contains general information on duct smoke detector installation, but does not preclude the NFPA and/or ICC documents listed. Greystone assumes no responsibility for improperly installed duct detectors. To determine the correct installation position for an DSD2G Series duct smoke detector, the following factors must be considered.

1. A uniform non-turbulent (laminar) airflow between 100 ft/min. to 4,000 ft/min. must be present in the HVAC duct. To determine duct velocities, examine the engineering specifications that define the expected velocities or use an Anor model 6000AP velocity meter (or equivalent).
2. To minimize the impact of air turbulence and stratification on performance, a duct smoke detector should be located as far as possible downstream from any obstruction (i.e. deflector plates, elbows, dampers, etc.). In all situations, confirmation of velocity and pressure differential within specifications is required.

The pressure differential between the input sampling (high pressure) tube and exhaust (low pressure) tube for the DSD2G Series smoke duct detector should be greater than 0.01 inches of water and less than 1.2 inches of water.

3. Identify a code compliant location (supply or return side, or both) for the installation of the duct unit that will permit easy access for viewing and serviceability.
4. When installing on the return side, install duct units prior to the air being exhausted from the building or diluted with outside "fresh" air.
5. When installing duct smoke units downstream of filters, fires occurring in the filters will be detected, but if the filters become blocked, insufficient air flow through the duct unit will prevent the correct operation of the duct detector. Duct units installed in the supply air side may monitor upstream equipment and/or filters.
6. Where possible, install duct detectors upstream of air humidifiers and downstream of dehumidifiers.
7. To prevent false alarms, the duct detector should not be mounted in areas of extreme high or low temperatures, in areas where high humidity exists, or in areas where the duct may contain gases or excessive dust.

SAMPLING TUBE ASSEMBLY

The DSD2G Series duct smoke detectors employ a specially notched sampling tube, which must be ordered separately in one of four standard lengths or packaged as FAST Tubes.

- STN-1.0 For duct widths of 6" TO 1.0'
- STN-2.5 For duct widths of 1.0' TO 3.0'
- STN-5.0 For duct widths of 3.0' TO 5.0'
- STN-10.0 For duct widths of 5.0' TO 10.0'
- FAST TUBE Sectional tube for duct widths up to 8.0'

Standard sampling tubes are steel tubes with air intake holes drilled the entire length of the tube. FAST Tubes are a recognized plastic with an open slot along the length. These tubes can be cut to length and must span at least 80% of the duct width (spanning the entire width is suggested). Sampling tubes over 3ft must be supported on the opposite side of the duct. To ensure correct operation of the sampling tube, the red end cap (red stopper in installation kit) must be inserted in the end of the air intake. For custom duct widths, always use the next longest standard size and cut down to the exact requirement.

"NO-TOOLS" TUBE INSTALLATION

The DSD2G Series duct smoke detector provides a unique, patented mechanism for installation and/or removal of the sampling and exhaust tubes from either the front or rear of the detector housing.

Once the airflow direction has been determined, insert the inlet and exhaust tubes into the duct smoke detector. If the cover is in place, the tubes may be inserted into the back of the detector via the key-slots provided. Simply push the tube into place against the spring loaded retainer, and turn into the correct position, allowing the key to "lock" the tube in the desired orientation. For front side installation, simply rotate the tube retainer until the tube may be inserted and oriented properly. Once the tube is installed, rotate the retainer back into place to lock down the tube. Ensure air intake sampling tube is positioned so that the inlet holes (or FAST Tube slot) are directly facing the airflow.

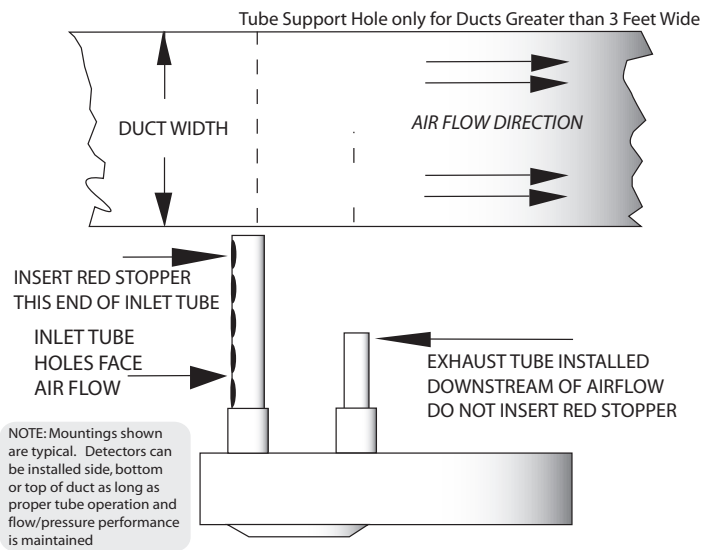

DUCT PREPARATION

Remove mounting template from the installation kit. Remove paper backing from the mounting template and affix it to the duct at the desired location. Using the template as a guide, drill (2) mounting holes, 3/32" (2.5mm) for the #12 X " sheet metal screws packaged in the installation kit. Drill or punch (2) 1" (32mm) holes for inlet sampling and exhaust tubes, using the template as a guide. Clean all holes.

MOUNTING

After securing the sampling and exhaust tubes to the duct smoke unit, (or initially placing the tubes through the 1" holes drilled or punched in the HVAC duct to accept the inlet sampling and exhaust tubes and then attaching them to the duct unit), hold the duct unit assembly in position and use (2) # 12 X " sheet metal screws (packaged in the installation kit) to secure the duct smoke detector to the HVAC duct sheet metal.

AIR SAMPLING VERIFICATION

To ensure correct operation of the duct unit use a Magnehelic differential pressure gauge, Dwyer 2000 or 4000 Series (or equivalent) to determine the differential pressure between the inlet (high side) and exhaust (low side) tubes. The differential pressure between the two tubes should be greater than 0.01 inches of water and less than 1.2 inches of water.

AIR SAMPLING VERIFICATION (CONT'D)

This duct smoke detector is shipped with a velocity adapter insert, factory installed (DSD2G). When installed, this adapter will allow the duct detector to operate at extremely low air velocities. To install the adapter, simply insert it into the slots provided inside the detector housing so that the adapter fits snugly over the smoke detector head. Unless your system is consistently operating in the slower velocity range, we recommend that the adapter not be inserted. If you experience false alarms at higher velocities with the adapter in place, the adapter should be removed. Please use the following chart for guidance on when the velocity adapter should be used. For reference, the speeds indicated are intended to represent the velocity of air within the duct under normal operational conditions.

	100 ft/min	300 ft/min	500 ft/min	1,000 ft/min	2,000 ft/min	3,000 ft/min	4,000 ft/min
DSD2G	UL Listed without insert installed (1,000-4,000 ft/min)						
	UL Listed with insert installed (100-4,000 ft/min)						

ELECTRICAL INSTALLATION

TERMINAL AND POWER CONNECTIONS

Prior to connecting input power to the duct unit, determine the correct input voltage/ current availability and ensure it is connected to the correct terminals.

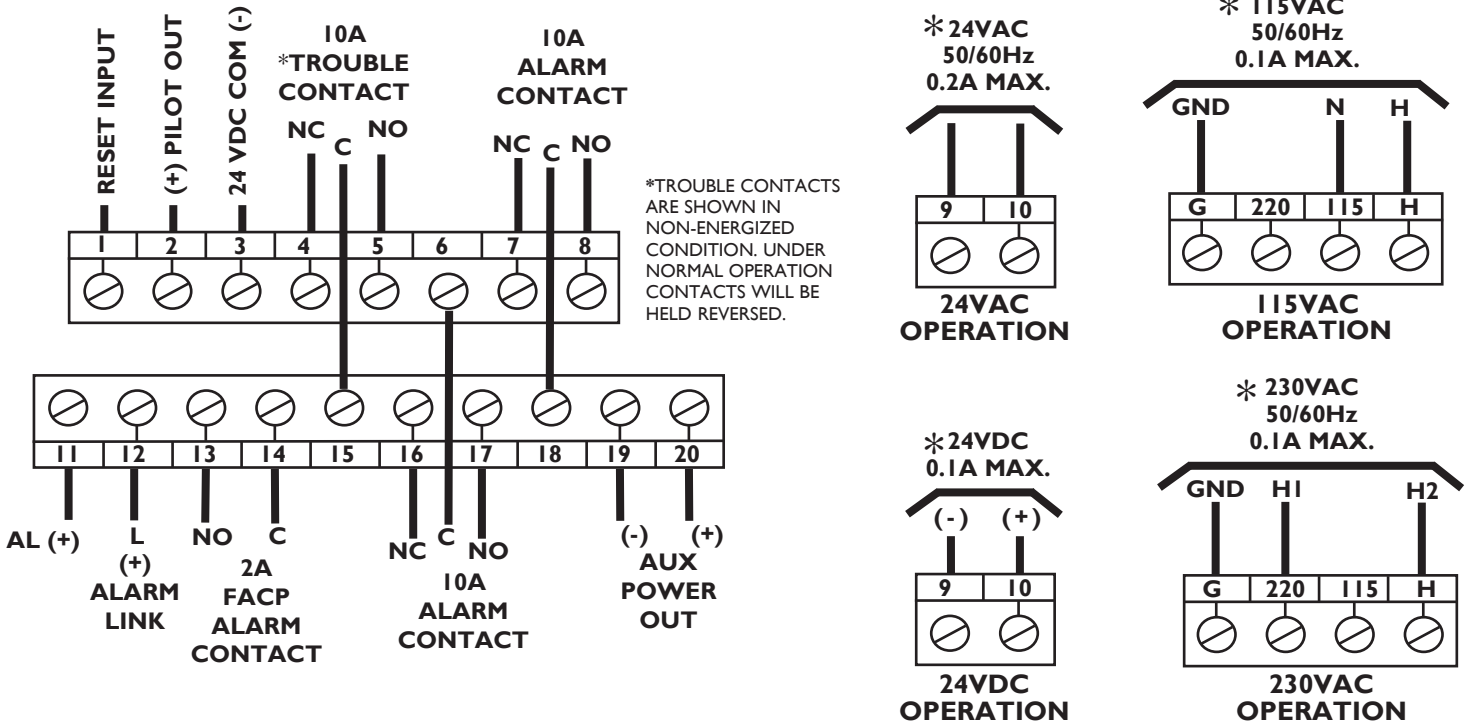

* NOTE: Choose only one source of operating voltage

WIRING

CAUTION: Do not use looped wire under terminals. Break wire run to provide for proper supervision of connections.

MISE EN GARDE: Ne pas enrouler le fil sous les bornes. Pour assurer la supervision électrique des raccordements, il faut couper les fils.

With detector head removed, connect one of the appropriate dedicated power sources to the applicable terminals (see above). Replace detector head and depress the cover removal switch (SW1) and the unit will be energized. The green pilot LED will be illuminated, and when pressing the test/reset button (SW2), the red alarm LED will be illuminated. This test confirms the correct basic operation of the duct smoke unit, excluding the detector head (see functional testing).

In the event of a fire alarm, certain equipment may be required to be shut down. For example, shut down may be achieved by interrupting the fan supply source to that particular piece of equipment when wired as indicated on Page 4.

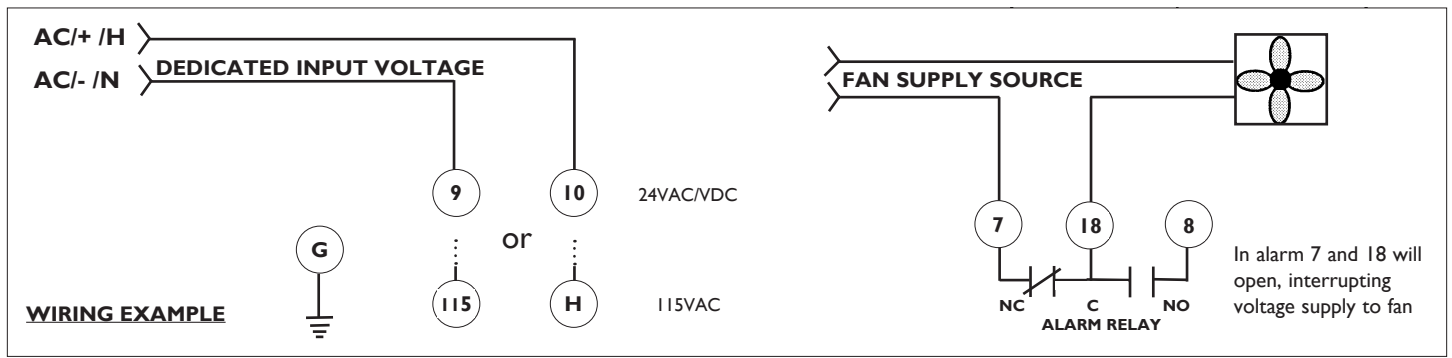

FIRE ALARM CONTROL PANEL WIRING

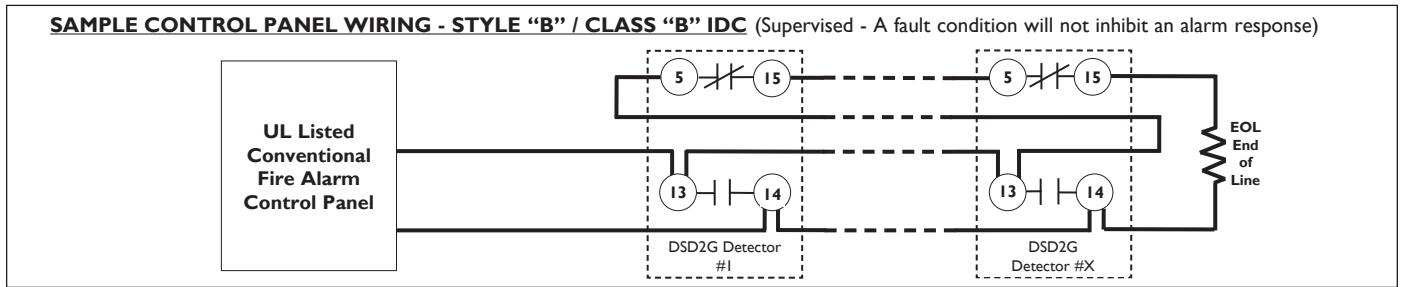
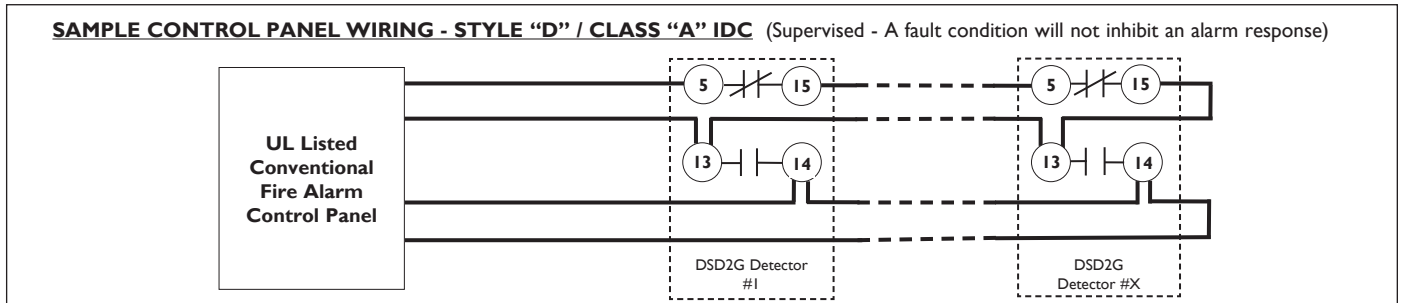

MSR REMOTE ACCESSORY WIRING

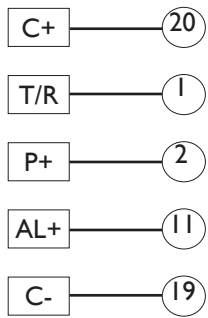

CONNECTIONS SHOWN FOR ALL POSSIBLE TERMINAL STYLE CONFIGURATIONS.

CONNECT ONLY THOSE TERMINALS AVAILABLE ON THE MSR REMOTE ACCESSORY CONTROL ASSEMBLY.

MS REMOTE ACCESSORY WIRING

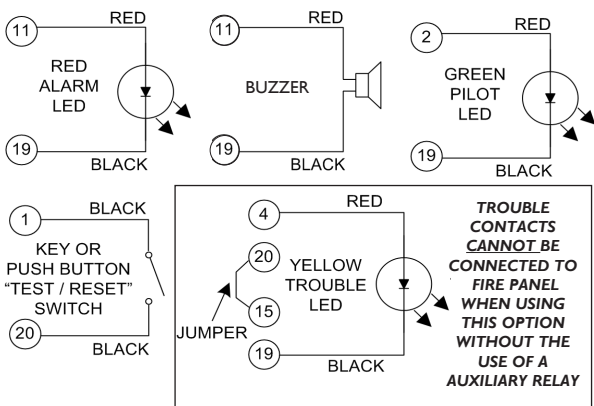

INTERCONNECTION WIRING FOR COMMON FUNCTIONS

* **NOTE:** A common power supply must be used for all interconnected detectors.

Common Test/Reset

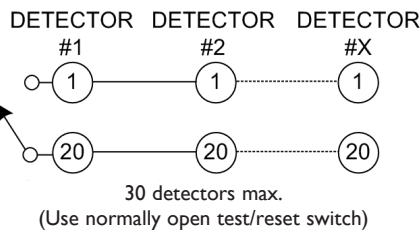

Common Alarm Shutdown

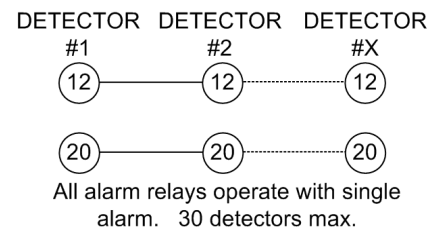

Adding Individual Horn/Strobes

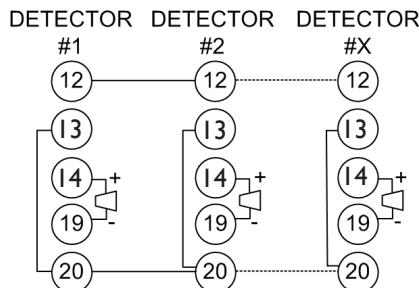

Adding Common Alarm Horn/Strobes

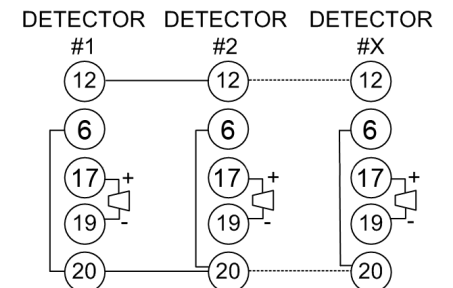

TESTING AND MAINTENANCE PROCEDURES

OPERATIONAL TESTING

To determine the correct operation of the DSD2G Series duct smoke detector, ensure input power is connected and the green pilot LED is illuminated.

The LED on the detector head will flash while the unit is in standby mode. The LED on the smoke detector head will be permanently illuminated when smoke is detected and the head is in alarm.

With the air handling unit shut down (not connected), and the clear cover

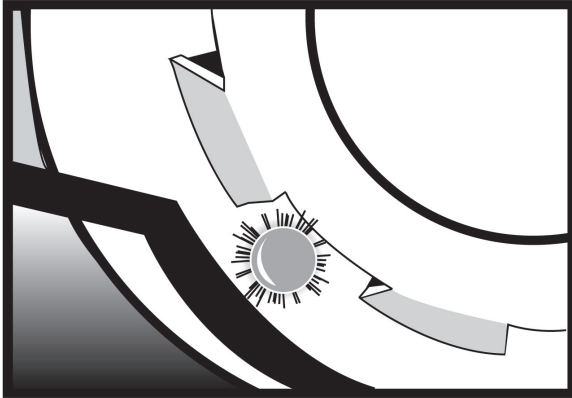

Above: The LED will be permanently illuminated when the unit is in alarm.

removed, press and hold the test/reset button and the cover removal switch on the DSD2G. The red alarm LED on the circuit board will be illuminated and the alarm relay outputs will change state. Using a multimeter set to OHMS (or continuity buzzer function on the meter) place the meter probes on the following terminals, and ensure the contacts are closed (continuity) (8-18) and (6-17). When releasing the test/reset button these contacts will open.

The trouble contacts (4,15,5) on the DSD2G detector will not change state in the event of a fire alarm, operational, or functional testing. The trouble contacts can be tested by either releasing the cover removal switch, or depressing the cover removal switch after rotating the smoke detector head counter-clockwise and removing the detector head. This action will extinguish the green pilot LED and cause the trouble contacts to change state, (4-15) will be closed (continuity) and (5-15) will be open circuit. Replacing the detector head and rotating it clockwise until it locks, will cause the green pilot LED to be illuminated and the unit will be operational, terminals (4-15) will be an open circuit and (5-15) will be closed (continuity).

FUNCTIONAL TESTING

Once operational testing is concluded the unit requires functional testing to determine the correct operation of the detector head.

MAGNET TESTING: Place the magnet provided with the installation kit on top of the housing between the raised sections above the detector head (as indicated by the arrows on the unit cover). Allow at least five seconds for alarm initiation. Remove magnet and reset detector.

SMOKE TESTING: Using smoke test canister with testing nozzle (Greystone part number TG-2000), insert the test gas nozzle into the test port on the unit cover. Press can against cover to release gas into the chamber.

CAUTION: DO NOT SPRAY GAS FOR MORE THAN ½ SECOND. TEST GAS FACILITY MAY RESULT IN DETECTOR CONTAMINATION.

⚠ MISE EN GARDE: NE VAPORISEZ PAS DE GAZ POUR PLUS DE ½ SECONDE. SURUTILISATION DES GAZ DE TEST INSTALLATION PEUT ENTRAÎNER LA CONTAMINATION DU DÉTECTEUR.

After 15 to 20 seconds the detector head will go into alarm, illuminating the detector head LED and causing the duct unit functions to operate, alarm relays will change state, and the alarm related remote accessories, if attached, will function.

If no test gas is available to conduct functional testing, remove cover and, while holding down the cover removal switch, blow smoke from a cotton wick or punk directly at the head to cause an alarm. The alarm indicator should illuminate within one minute.

Should additional testing also be required for simulated fire conditions, smoke bombs placed in the duct may not be suited for the particular detector head selected and installed. Consult the smoke bomb data for proper use and compatibility with detector type.

The S65A photoelectric detector head (55000-328APO) operates on the principle of light scatter and will detect smoke particles of between 1 and 10 microns in size.

When purchasing smoke bombs for additional required functional testing, ensure smoke particle sizes comply with the criteria as described above.

NOTE: In situations that require a duct smoke detector to be held in an alarm condition for an extended period of time, the magnet test or smoke test methods should be used to ensure the detector is locked into alarm.

MAINTENANCE

Each installation location must be assessed on its own merits. If the protected area is of a very dirty nature then the DSD2G Duct unit(s) will have to be checked and cleaned on a quarterly basis or when cleaning is required.

As a guideline the smoke detector head should be cleaned every six months or as required. The best methods of cleaning are to vacuum the detector head thoroughly or to blow the detector head out using clean, dry compressed air.

Do not use chemicals or non-conforming air to clean the detector head housing as this could contaminate the detector head and damage the casing.

Sensing tubes must be inspected and cleaned in accordance with the schedule as determined above, to allow the free flow of air through both inlet and exhaust tubes.

Consult your local code and AHJ requirements for required maintenance schedules.



GREYSTONE
ENERGY SYSTEMS INC

150 English Drive, Moncton, NB E1E 4G7, Canada
Tel: +1-506-853-3057 Fax: +1-506-853-6014
www.greystoneenergy.com

AVAILABLE ACCESSORIES FOR USE WITH DSD2G SERIES DUCT SMOKE DETECTORS

MSR-1 00 SERIES Remotes with LEDs for alarm/pilot trouble, with programmable buzzer, silence feature with a key test/reset

MSR-100R/R Red plate
MSR-100R/W White plate
MSR-100RA/W Plugin sounder in a white plate
MSR-100RV/W/C Plugin strobe in a white plate

MSR-50 Series Remotes with a multicolor indicator for alarm, pilot and trouble

MSR-50RK/R Key test/reset in a red plate
MSR-50RK/W Key test/reset in a white plate
MSR-50RKA/R Key test/reset and a plugin sounder in a red plate
MSR-50RKA/W Key test/reset and a plugin sounder in a white plate
MSR-50RKAV/R/C Key test/reset and a plugin sounder/strobe in a red plate
MSR-50RKAV/W/C Key test/reset and a plugin sounder/strobe in a white plate
MSR-50RM/R Magnet test & pushbutton reset in a red plate
MSR-50RM/W Magnet test & pushbutton reset in a white plate

MSR-AV/T Series Stand-alone Sounders with LED Strobe

MSR-AV/TR/C Red plate
MSR-AV/T/W/C White plate

MS-SERIES Remotes in brushed steel plate

MS-RA Remote Alarm for Single Gang Box Labeled Alarm
MS-KA/R Remote with Red Alarm LED & Key test reset

SMOKE TEST GAS

TG-2000 Solo Aerosol Test Gas with Nozzle for Test Port
TG-2500 Centurion Aerosol Test Gas with Nozzle for Test Port

SAMPLING TUBES

STN-1.0 For duct widths of 6" to 1.0'
STN-2.5 For duct widths of 1.0' to 3.0'
STN-5.0 For duct widths of 3.0' to 5.0'
STN-10.0 For duct widths of 5.0' to 10.0'
FAST Tube Sectional Tube for Duct Widths up to 8ft

REPLACEMENT SMOKE DETECTOR HEADS

55000-328APO S65A Replacement Smoke Detector Head (pending obsolescence)
55000-335DCT Replacement Smoke Detector Head

POWER SUPPLIES

T-PB 202-1 24VAC @ 4.0A Class I Power Supply
T-PB 202-0 24VAC @ 4.0A Class I Power Supply
T-PB 303-1 24VAC @ 3.0A Class II Power Supply
T-PB 303-0 24VAC @ 3.0A Class II Power Supply

APD1068 A240401



INSTALLATION AND MAINTENANCE INSTRUCTIONS

DSD2G DUCT SMOKE DETECTORS



DSD2G Photoelectric 4-Wire Duct Smoke Detector



ANSI APPROVED / UL LISTED to the 268A Standard for Smoke Detectors for Duct Application:
UROX, UROX7, File No S2829

CSFM LISTED: 3240-1004:105 • MEA ACCEPTED: 73-92-E VOL 27

NOTICE: The information contained in this document is the most current available at the time of shipment of accompanying product, and is subject to change without notice. Future references should always be made to the most current revision of this document. The information contained in all this document should be considered before installing or using the product. Any example applications shown are subject to the most current enforced local/national codes, standards, approvals, certifications, and/or the authority having jurisdiction. All of these resources, as well as the specific manufacturer of any shown or mentioned related equipment, should be consulted prior to any implementation. For further information or assistance concerning this product, contact Greystone Systems Inc. Greystone Systems Inc. reserves the right to change any and all documentation without notice.
© Greystone Systems Inc. 2009

**A COPY OF THESE INSTRUCTIONS SHOULD BE LEFT WITH THE EQUIPMENT
UNTIL INSTALLATION BY ALL TRADES IS FULLY COMPLETE.
FOLLOWING FINAL INSPECTION, A COPY SHOULD BE LEFT WITH THE OWNER/USER.**

FOR TECHNICAL SUPPORT CALL +1-800-561-5611 (NORTH AMERICA ONLY) or +1-506-853-3057