

INTRODUCTION

The dewpoint transmitters are designed for use in environmental monitoring and control systems where high performance and stability are demanded. It's state-of-the-art design combines digital linearization and temperature compensation with a highly accurate and reliable thermoset polymer based capacitance humidity sensor and curve-matched NTC thermistor temperature sensor for reliability and accuracy in the most critical applications. The dewpoint transmitter has four measurement variables which include dewpoint, dry-bulb temperature, wet-bulb temperature and enthalpy which are available from 2 analog output signals to provide the most efficient monitoring and control solution.

BEFORE INSTALLATION

Read these instructions carefully before installing and commissioning the dewpoint transmitter. Failure to follow these instructions may result in product damage. Do not use in an explosive or hazardous environment, with combustible or flammable gases, as a safety or emergency stop device or in any other application where failure of the product could result in personal injury. **Take electrostatic discharge precautions during installation and do not exceed the device ratings.**

MOUNTING

The dewpoint transmitter installs directly into any air duct with a minimum width/diameter of 25.5 cm (10"). Select a suitable installation area in the middle of the duct wall. To achieve the best reading, do not place in an area where air stratification may be present. **Mount the sensor at least 1.5 m (5') in either direction from elbows, dampers, filters or other duct restrictions. Avoid areas where the transmitter is exposed to vibrations or rapid temperature changes.**

Drill or punch a 32-35mm (1.25" x 1.375") hole in the duct at the preferred location and insert the probe into the hole to mark the enclosure mounting holes. Remove the unit and drill the four mounting holes. Clean all drilled holes of debris before mounting the device. Mount the enclosure to the duct with four #10 sheet metal screws (not included). To prevent air leaks, ensure the gasket is compressed around the probe between the device enclosure and the air duct. As shown in Figure 1.

The enclosure has a hinged cover with latch. Open the cover by pulling slightly on the latch on the right side of the enclosure and at the same time pulling on the cover, as illustrated in Figure 2.

A 21 mm (0.8125") hole is provided for connection of either a 1/2" conduit connector or a cable gland style connector. Insert the conduit or cable gland connector through the hole and securely fasten using a locknut as shown in Figure 3.

Make wire connections as per the "Wiring" illustrations on Page 2.

Two security screws are provided which can be installed to help secure the cover once settings and wiring connections are complete. See Figure 4.

Figure 1

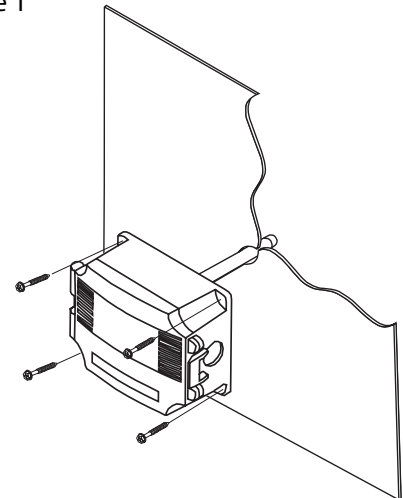

Figure 2

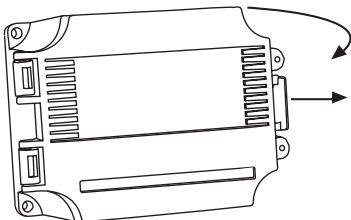

Figure 3

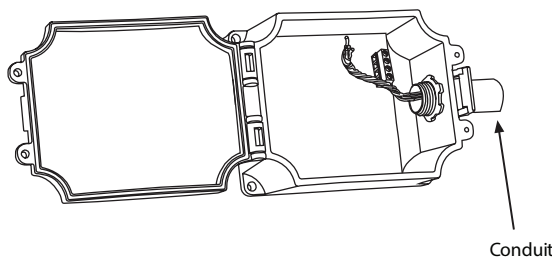
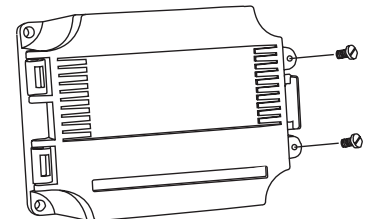

Figure 4



WIRING

- Deactivate the 24 Vac/dc power supply until all connections are made to the device to prevent electrical shock or equipment damage.
- Follow proper electrostatic discharge (ESD) handling procedures when installing the device or equipment damage may occur.
- Use 22 AWG shielded wiring for all connections and do not locate the device wires in the same conduit with wiring used to supply inductive loads such as motors.
- Make all connections in accordance with national and local codes.

Connect the 24 Vac/dc power supply to the terminals labeled PWR (power) and COM (common) as shown in Figure 6. This device has a half-wave type power supply so use caution when wiring multiple devices so that the circuit ground point is the same on all devices and the controller. Use caution if 24 Vac power is used and one side of the transformer is earth-grounded. In general, the transformer should NOT be connected to earth ground when using devices with RS-485 network connections. The device is reverse voltage protected and will not operate if connected backwards.

Figure 5

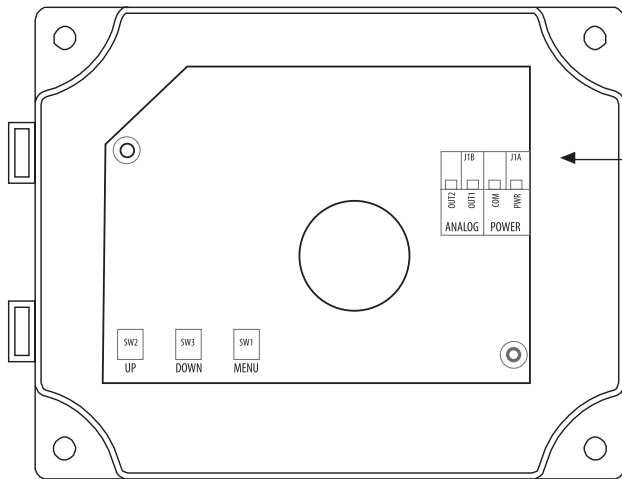
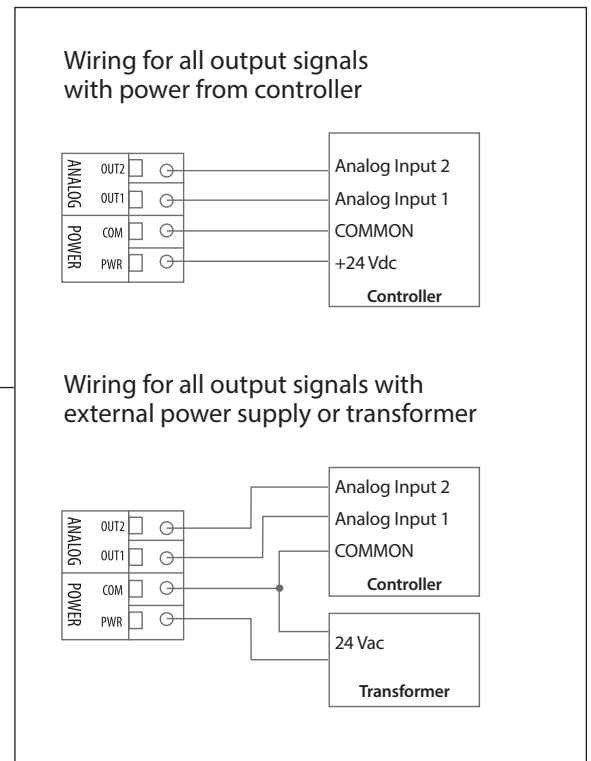
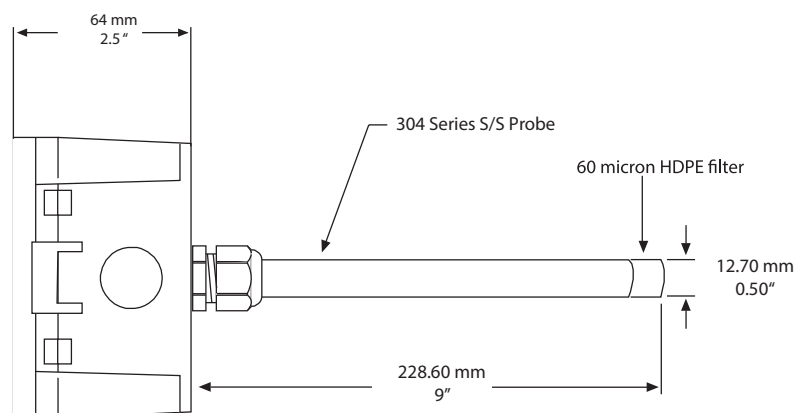
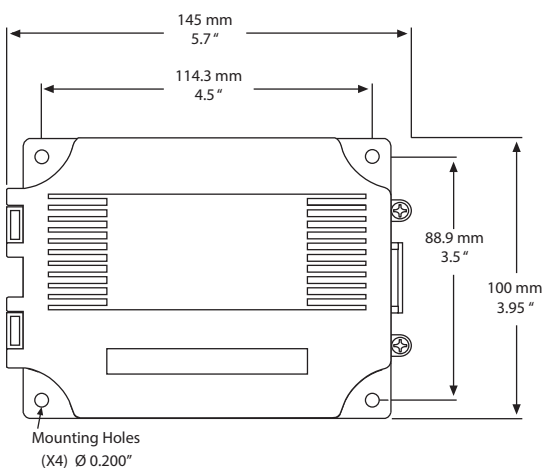

Figure 6



DIMENSIONS



OPERATION

Start-Up Mode

When the device is powered on, it will go through a brief start-up mode. The LCD will display a sequence of information depending on the model. At the end of the start-up sequence, normal operation will begin.

STEP 1 LCD Test

All segments lit for 2 seconds



STEP 2 Model

Displays the model type for 2 sec.
(Volt or current depending on model ordered)



STEP 3 Software Version A1.0 for 2 sec



Normal Mode

In normal operation the device:

- reads the temperature and RH sensors
- calculates values for dewpoint, wet bulb and enthalpy
- updates the LCD values
- updates the analog outputs
- monitors the menu key for activity

If the <MENU> key is pressed, normal operation is suspended while the menu functions are serviced. The program will automatically exit the menu after a period of inactivity.

MENU

The device has several parameters that can be configured locally via the User menu using the keypad and LCD. All parameters default to typical values but the installer may want to change some values. In some cases, such as the device network address, the installer MUST change the settings before operation. Any changes made are saved in non-volatile memory and are restored in case of a power loss. Only the menu items relevant to the device model will be shown. The menu can be accessed at any time after the start-up mode and if there is 5 minutes of inactivity the menu will close and normal operation will continue.

User Menu – Analog Device

To enter the menu, press and release the <MENU> key. This will enter the User menu step 1, pressing the <MENU> key a second time advances to step 2. Each press of the <MENU> key saves the current setting and advances the menu item. The <UP> and <DOWN> keys are used to make changes to program variables by scrolling through the available options. When a value is changed, use the <MENU> key to save it to memory and advance to the next menu item.

<MENU> Press and release to enter the User menu.

5V / 10V (default = 5V)

(This item is only shown for the voltage output model.)

Use <UP> or <DOWN> to toggle the selection.

<MENU>

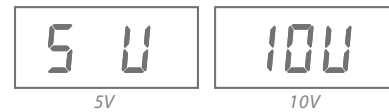

Output Signal 1 Temperature Range (default = -30-50 °C)

This item sets the dry bulb temperature range for OUT1.

Use <UP> or <DOWN> to toggle -30-50 °C, 0-50 °C,

-22-122 °F or 32-122 °F.

<MENU>

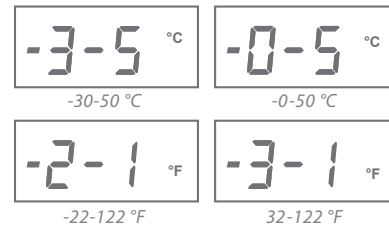

Output Signal 2 (default = Td)

This item selects the OUT2 parameter.

Use <UP> or <DOWN> to toggle Td, Tw or Enthalpy.

The display is either "Td", "Tw" or "kJ/kg + BTU/lb".

<MENU>



Only 1 of the next 3 items is shown, depending on what parameter is selected for Output Signal 2

The shown scale (C/F) depends on the previous Temperature Range selection

Dewpoint Temperature Range (default = -30-50 °C or -22-122 °F)

This item sets the dewpoint temperature range for OUT2.

Use <UP> or <DOWN> to toggle either -30-50, -20-40 or 0-50 for °C,

or -22-122, -4-104 or 32-122 for °F.

Td is lit + either °C or °F.

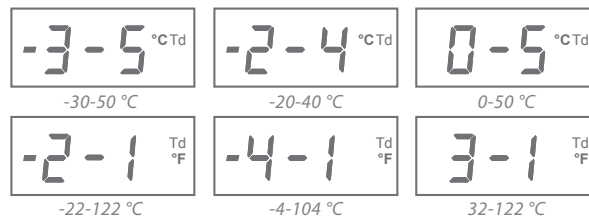

Wet Bulb Temperature Range (default = -20-50 °C or -4-122 °F)

This item sets the wet bulb temperature range for OUT2.

Use <UP> or <DOWN> to toggle either -20-50 or 0-50 for °C, or -4-122 or 32-122 for °F.

The display is similar to Td, except Tw is lit + either °C or °F + -2-5, 0-5, -4-1 or 3-1.

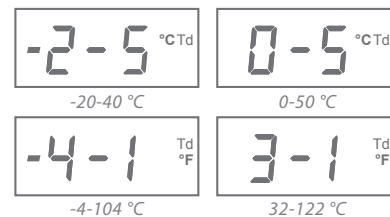

Enthalpy Range

(default = 0-340 kJ/kg)

This item sets the enthalpy range for OUT2 and also the units.

Use <UP> or <DOWN> to toggle either 0-250 kJ/kg, 0-340 kJ/kg, 0-107 BTU/lb or 0-146 BTU/lb. Unit is lit + max value.



<MENU>

LCD

(default = Out1)

This item selects what parameter are displayed on the LCD.

Use <UP> or <DOWN> to toggle Out1, Out2 or both (toggle).

The display is either L1, L2 or L12.



<MENU>

Temperature Offset

(default = 0 °C or 0 °F)

This item is for field calibration and is used to add an offset to the temperature measurement.

Use <UP> or <DOWN> to change from -10-10 °F or -5-5 °C. Either °C or °F is lit.



<MENU>

**RH Offset**

(default = 0 %RH)

This item is for field calibration and is used to add an offset to the RH measurement.

Use <UP> or <DOWN> to change from -10-10 %RH.



<MENU>

Altitude

(default = 0 ft)

This item is to set the local altitude to increase calculation accuracy.

Use <UP> or <DOWN> to change from A 0 to A60. Resolution is 100 ft steps.



<MENU> Exits the menu and returns to normal operation.

SENSOR TYPE:

RH Sensor	Thermoset polymer based capacitive
Temperature Sensor	NTC Thermistor

MEASUREMENT RANGE:

Relative Humidity	0 - 100 %RH
Dry Bulb Temperature	-30 - 50 °C (-22 - 122 °F)

CALCULATED VALUES:

Dewpoint Temperature	-30 - 50 °C (-22 - 122 °F)
Wet Bulb Temperature	-30 - 50 °C (-22 - 122 °F)
Enthalpy	0 - 340 kJ/kg (0 - 146 BTU/lb)

ACCURACY:

Relative Humidity (RH)	± 2% RH, 10 - 90 %RH @ 25 °C
Dry Bulb Temp.(T)	± 0.2 °C (± 0.4 °F) / 0 - 50 °C (32 - 122 °F)
Dewpoint Temp. (Td)	± 1.0 °C (± 1.8 °F) @ 40 %RH / 25 °C
Wet Bulb Temp.(Tw)	± 1.0 °C (± 1.8 °F) @ 50 %RH / 25 °C
Enthalpy (En)	± 2 kJ/kg (± 1 BTU/lb) @ 50 %RH / 25 °C

OUTPUT:

Output Signals (2X)	4 - 20 mA or 0-5/0-10 Vdc (factory set)
Signal 1	Dry Bulb Temperature (field selectable range) T Range 1 = -30 - 50 °C (-22 - 122 °F) T Range 2 = 0 - 50 °C (32 - 122 °F)
Signal 2	Dewpoint Temperature, Wet Bulb Temperature or Enthalpy (field selectable) Td Range 1 = -30 - 50 °C (-22 - 122 °F) Td Range 2 = -20 - 40 °C (-4 - 104 °F) Td Range 3 = 0 - 50 °C (32 - 122 °F) Tw Range 1 = -20 - 50 °C (-4 - 122 °F) Tw Range 2 = 0 - 50 °C (32 - 122 °F) En Range 1 = 0 - 340 kJ/kg (0 - 146 BTU/lb) En Range 2 = 0 - 250 kJ/kg (0 - 107 BTU/lb)
Output Impedance	500 Ω max for current (@ 24 Vdc), 10 KΩ min for voltage

SPECIFICATIONS:

Power Supply	20 - 27 Vdc, 16 - 27 Vac (non-isolated half-wave rectified)
Consumption:	
Current model	50 mA max @ 24 Vdc, 1.5 VA max @ 24 Vac
Voltage model	30 mA max @ 24 Vdc, 1 VA max @ 24 Vac
Operating Conditions	-30 - 50 °C (-22 - 122 °F), 0 - 95 %RH non-condensing
Storage Conditions	-40 - 70 °C (-40 - 158 °F), 0 - 95 %RH non-condensing
Wiring Connections	14 - 22 AWG terminal block
Enclosure	
Dimensions	145W x 100H x 64D mm (5.7W x 3.95H x 2.5D in)
Material	Grey ABS, UL94-5VB
Ratings	IP65 (NEMA 4X)
Probe	230 mm (9") L x 12.7 mm (1/2") D 304 S/S with porous filter
Weight	320 gm (11.3 oz)
Approvals	CE, RoHS

LCD DISPLAY VALUES:

Temperature	-30.0 - 50.0 °C (0.5 °C resolution) or -22 - 122 °F (1 °F resolution)
Dewpoint	-30.0 - 50.0 °C Td (0.5 °C resolution) or -22 - 122 °F Td (1 °F res.)
Wet Bulb	-20.0 - 50.0 °C Tw (0.5 °C resolution) or -4 - 122 °F Tw (1 °F res.)
Enthalpy	0 - 340 kJ/kg (1 kJ/kg resolution) or 0 - 146 BTU/lb (1 BTU/lb resolution)