

#### INTRODUCTION

The CS-625 current switch is a solid-state switch that monitors line current for electrical loads such as pumps, conveyors, machine tools or fans and closes the output contacts when the adjustable trip point is exceeded. It is typically used to monitor motor operation and can be used to determine on/off status, proof of operation, motor failure or belt loss.

The sensor requires no external power as it is totally powered by induction from the primary AC line being monitored. The trip setpoint is adjustable in three jumper-selectable ranges from a minimum value (1 Amp) up to 175 Amps by rotating the adjustment pot counter-clockwise.

The output contacts can switch loads up to 1 Amp 240 Vac.

#### \*WARNING\*

- **Electric Shock Hazard, Use Caution**
- **Disconnect and lock out power before installation**
- Follow national and local electrical codes
- Read and understand these instructions before installing
- Installation only by qualified electrical personnel
- Do not rely on this device to indicate line power
- Only install this device on insulated conductors
- Only install on 600 Vac maximum conductors
- Do not use this device for life-safety applications
- Do not install in hazardous or classified locations
- Install this product in a suitable electrical enclosure
- Failure to follow these instructions may result in serious injury or death.

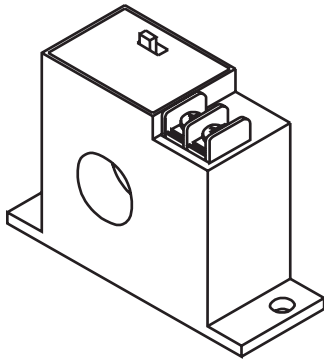

#### INSTALLATION

Read all warnings before beginning. Ensure the selected device has the correct ratings for application. Set the range jumper to the desired range. See Figure 1. Mount the sensor with two screws through the base.

The base has an integrated mounting tab to allow screw mount to a surface.

If predrilling is required, the actual device may be used to mark holes. The mounting holes in the base will accommodate up to a #10 size screw (Not supplied). See Figure 2. Place the monitored conductor through the sensor hole and reconnect. See Figure 3.

The CS-625 is not polarity sensitive. Use shielded wiring for all connections and do not locate the device wires in the same conduit with wiring used to supply inductive loads such as motors. Make all connections in accordance with national and local codes.

Reconnect the power.

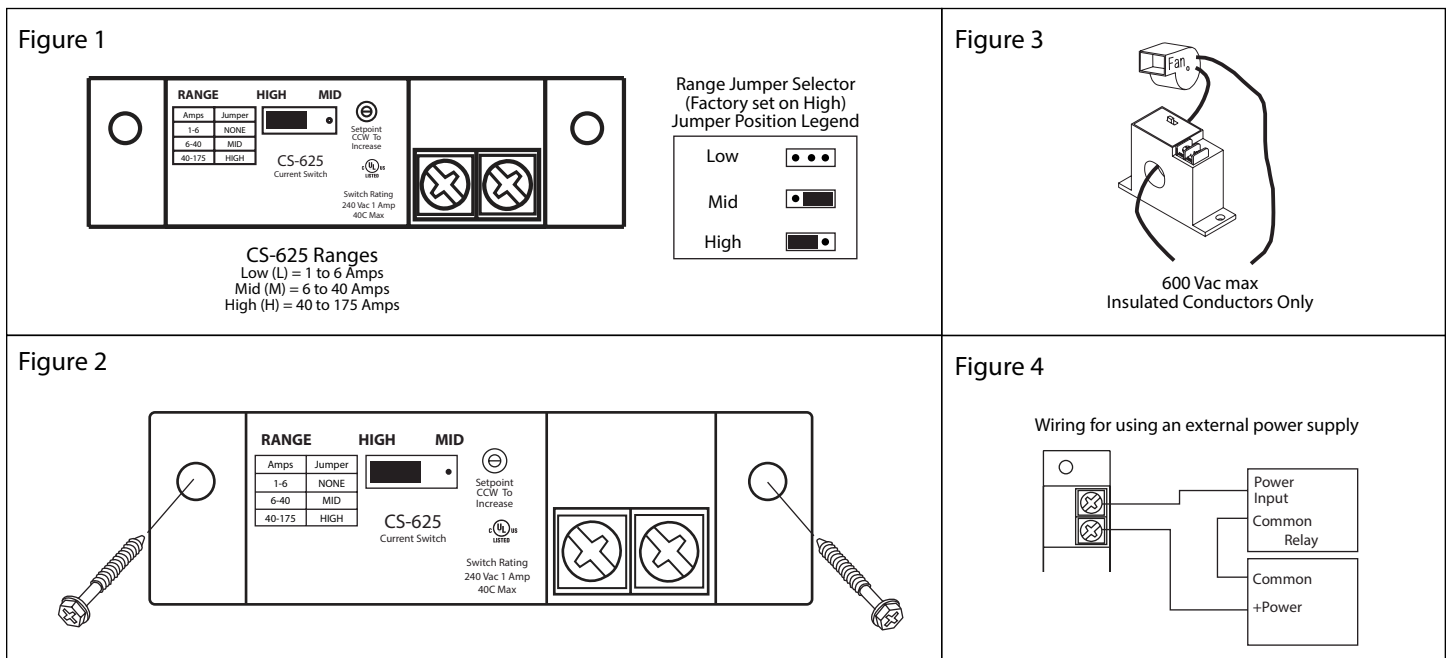

## CALIBRATION

With the sensor installed and range jumper set, turn on the monitored load (motor, heater, etc.) and allow it to run normally. Rotate the setpoint knob counterclockwise several times to make sure switch is open. Then slowly turn the knob clockwise until the switch closes. Turn clockwise slightly more to eliminate false switching.

The CS is now set to detect a current condition. A voltmeter can be used across the contacts to verify switch operation. Please note that the contacts cannot be tested for continuity with an ohmmeter.

## APPLICATIONS

For applications with load currents exceeding the sensor current ranges use an external CT to reduce the current to an acceptable value. For example, to measure a 500 Amp load current, use a 500A:5A CT and wrap the CT secondary through the CS-625 and place the CS-625 in the low range.

For applications with very small load currents (such as less than 1 Amp), wrap the monitored conductor through the sensor aperture several times to increase the current measured by the sensor. For example, to monitor a 0-1 Amp load with a CS-625, wrap the conductor through the sensor aperture 5 times so the sensor actually sees 0-5 Amps. Be careful the combined current of total of the wraps does not exceed the selected current range.

For any application with multiple wraps, note that the CS-625 maximum current rating must be divided by the number of wraps. For example, with one wrap the maximum current is 175 Amps, with 5 wraps the maximum current is  $175/5 = 35$  Amps. Ensure the load current is  $< 35$  Amps or the device may overheat and be damaged.

## SPECIFICATIONS

Setpoint Range.....	1 to 175 Amps adjustable
Maximum Input Current .....	<b>Low:</b> Max current 6 Amps
	<b>Mid:</b> Max current 70 Amps
	<b>High:</b> Max current 250 Amps
Sensing Ranges.....	<b>Low:</b> 1 to 6 Amps no-jumper
	<b>Mid:</b> 6 to 40 Amps
	<b>High:</b> 40 to 175 Amps
Sensor Power .....	Self-powered
Output Type .....	Solid-state
Output Switch Action .....	Normally open
Output Switch Ratings .....	240 Vac, 1 Amp maximum
Frequency .....	50/60 Hz
Reponse Time .....	<200 mA typical
Insulation Class .....	600 Vac, insulated conductors
Operating Temperature.....	-15 to 40°C (5 to 104°F)
Operating Humidity .....	5 to 90 %RH, non-condensing
Terminal Block .....	14 to 22 AWG
Dimensions.....	49mm x 87 mm x 25 mm (1.95" x 3.45" x 1")
Sensor Aperture .....	20 mm (0.8")
Enclosure Material.....	ABS, UL94 V0
Mounting Holes .....	(2) 5 mm holes spaces 75 mm on base
	(2) 0.19" holes spaced 3" on base
Agency Approvals .....	cULus Listed
Country of Origin.....	Canada

Figure 5

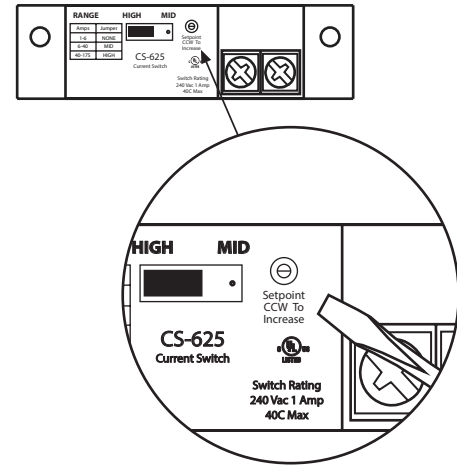
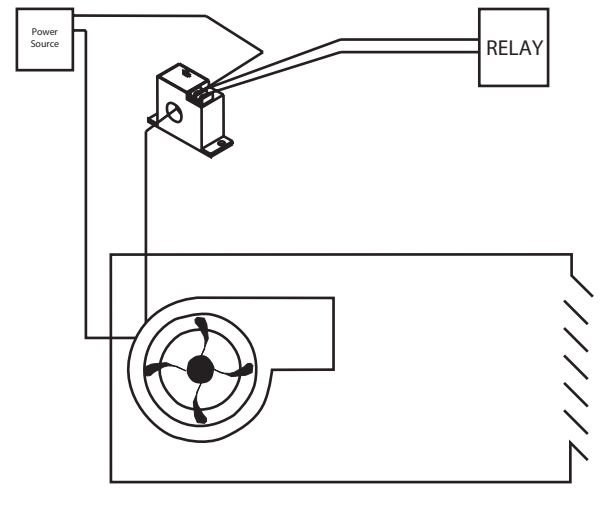
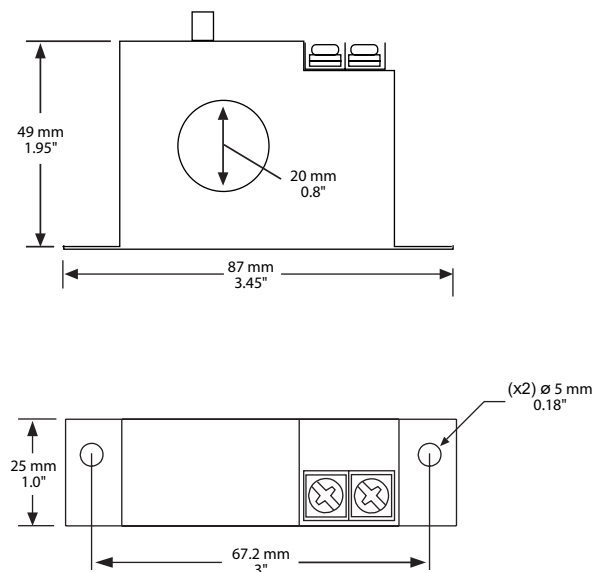

Figure 6



## DIMENSIONS



PRINTED IN CANADA