

INTRODUCTION

The High Current Switch / Dryer Fan Control is a solid-state current switches with N.O. triac outputs to control high current line-voltage AC loads. All models have a factory set trip level of approximately 1 Amp and require no field adjustment for easy installation. Internal circuits are powered by induction from the line being monitored

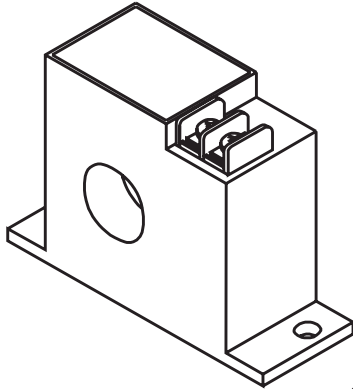

The High Current Switch / Dryer Fan Control series can operate a dryer booster fan directly. These devices sense when a clothes dryer is drawing 1 Amp of current and then closes the output switch to activate the dryer vent booster fan. When the dryer cycle is complete and the current drops below the threshold, the output switch will open or remain closed for a pre-set delay time to allow heat to be removed from the vent before the switch is opened again. The device output can switch 120 Vac loads up to 2.5 Amps. All models are UL certified.

WARNING

- **Electric Shock Hazard, Use Caution**
- Disconnect and lock out power before installation
- Follow national and local electrical codes
- Read and understand these instructions before installing
- Installation only by qualified electrical personnel
- Do not rely on this device to indicate line power
- Only install this device on insulated conductors
- Only install on 600 Vac maximum conductors
- Do not use this device for life-safety applications
- Do not install in hazardous or classified locations
- Install this product in a suitable electrical enclosure
- **Failure to follow these instructions may result in serious injury or death.**

INSTALLATION

Read all warnings before beginning. Ensure the selected device has the correct ratings for application.

Select a convenient location, with-in or adjacent to the breaker panel. Alternatively the sensor can be installed inside the dryer electrical compartment. Refer to Figure 4 through 7 for typical installations.

Mount the sensor with two screws through the base. The base has integrated mounting tabs to allow screw mount to a surface. If predrilling is required, the actual device may be used to mark holes. The mounting holes in the base will accommodate up to a #10 size screw (Not supplied). See Figure 1.

For 3-Phase systems, Disconnect and loop the neutral power wire, white, through the current sensor and reconnect. Connect the fan power supply, as shown 120 Vac max, to the top terminals of the current sensor. See Figure 2

For 220 Vac 3-wire single-phase systems, Determine which of the Hot wires is active for the dryer only. (this is necessary for stacked washer/dryer units). Verify that there is sufficient current to trip the current switch (minimum of 1 amp). If required the wire can be looped through twice to increase the current read by the switch. Connect the fan power supply, as shown 120 Vac max, to the top terminals of the current sensor. See Figure 3.

Figure 1

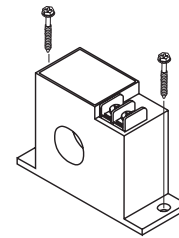

Figure 2

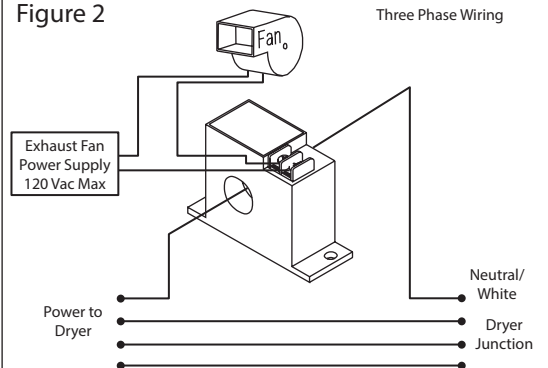

Figure 3

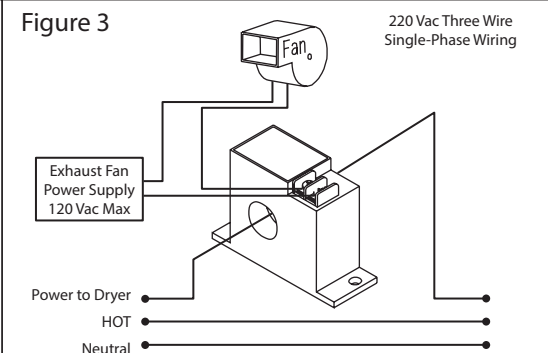

Figure 4

Installation as a dryer junction box (3 phase)

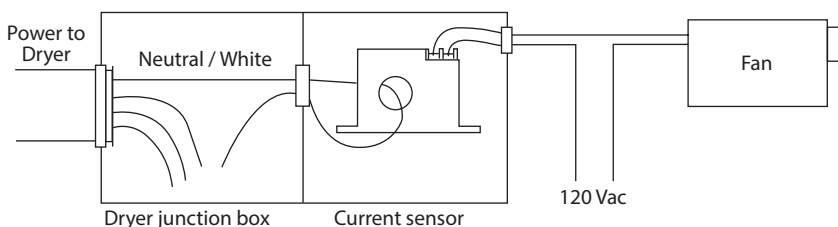

Figure 5

Installation as a dryer junction box (3-wire single phase)

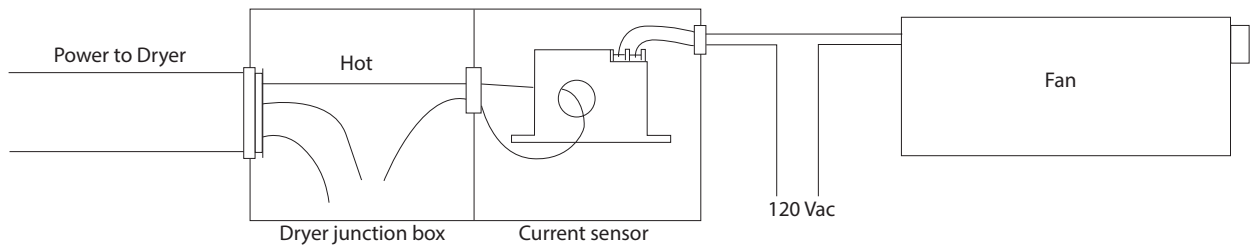

Figure 6

Installation at fuse/breaker panel (3-phase)

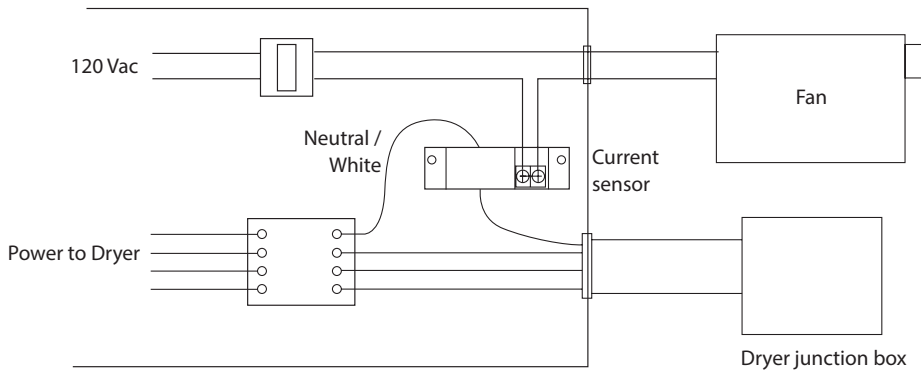
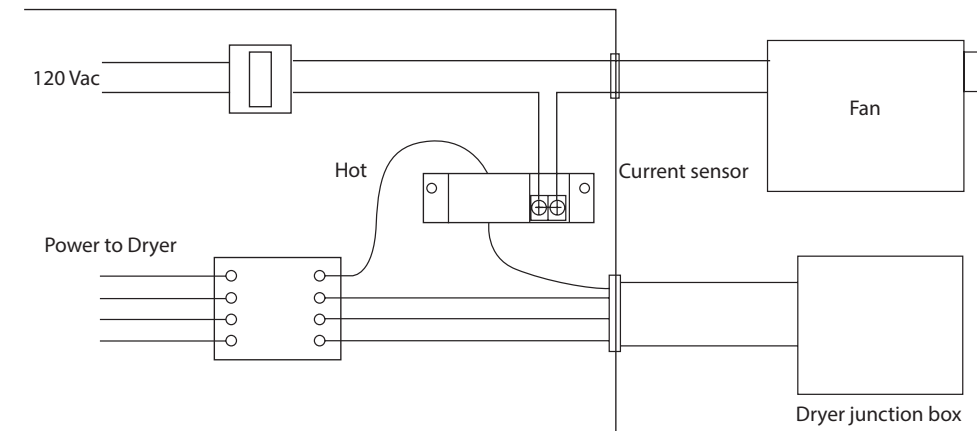

Figure 7

Installation at fuse/breaker panel (3-wire single phase)



SPECIFICATIONS

- Maximum Input Current50 Amps
- Trip Set-pointApproximately 1 Amp
- Switch Rating120 Vac @ 2.5 Amps maximum
- Switch Type.....Solid-state triac
- Off-State Leakage.....<1 mA
- Response Time<200 ms
- Delayed Off Time0, 5, 10, or 15 minutes
- Operating Conditions0 to 40°C (32 to 104°), 0 to 95 %RH non-condensing
- MaterialABS, UL94-V0, Insulation class 600V
- Enclosure Size49mm H x 87mm W x 25mm D (1.95" x 3.45" x 1.00")
- AC Conductor Hole.....20mm (0.8") diameter
- Mounting Holes(2) 5mm holes spaced 76mm apart on base,
(2) x 0.19" holes spaced 3" apart on base
- Agency ApprovalscULus listed
- Country of Origin.....Canada

DIMENSIONS

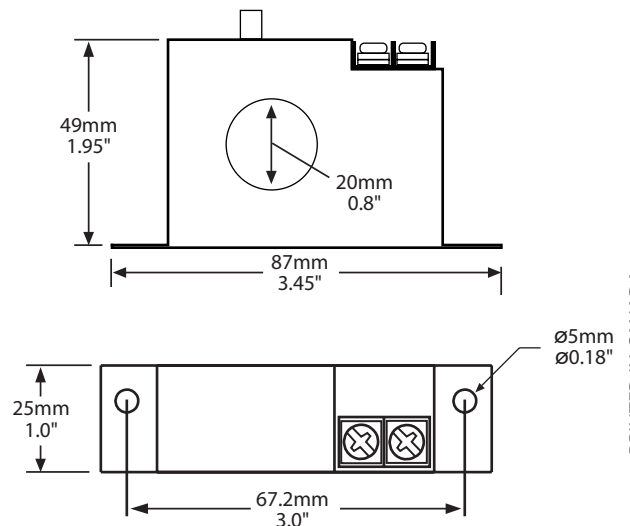

PRINTED IN CANADA