

### INTRODUCTION

The CO<sub>2</sub>/RH/T transmitter incorporates three sensors in one duct mount enclosure for the most efficient environmental monitoring and control system. It uses Infrared Technology to monitor CO<sub>2</sub> levels within an adjustable range of 0 – 10000 ppm, a field-proven RH sensor to monitor relative humidity from 0-100 %RH and a curve-matched thermistor to measure temperature over common field-selectable ranges. All three measurements are continuously available on separate outputs as linear analog signals. An optional pass-thru temperature sensor is also available. The device includes an LCD for configuration and operating parameters are programmed using a keypad for specific applications. Options include a control relay.

### BEFORE INSTALLATION

Read these instructions carefully before installing and commissioning the transmitter. Failure to follow these instructions may result in product damage. Do not use in an explosive or hazardous environment, with combustible or flammable gases, as a safety or emergency stop device or in any other application where failure of the product could result in personal injury. **Take electrostatic discharge precautions during installation and do not exceed the device ratings.**

**NOTE:** This CO<sub>2</sub> sensor incorporates a Self Calibration feature to correct CO<sub>2</sub> sensor drift. This feature is recommended for applications where the CO<sub>2</sub> will be exposed to fresh air (400 ppm) at least one hour per day. If the monitored space is occupied 24 hours or consistently maintains higher or lower levels of CO<sub>2</sub>, it is recommended that this feature be turned off, but yearly calibration will be required. If the self calibration is disabled at installation time without allowing for 7 day auto calibration cycle, then a manual calibration should be performed to ensure accuracy of the device.

### MOUNTING

The duct type sensor installs on the outside of a return air duct with the sampling tube inserted into the duct.

Mount the sensor in an easily accessible location in a straight section of duct at least five feet from corners and other items that may cause disturbances in the air flow. Avoid areas where the detector is exposed to vibrations or rapid temperature changes.

The duct CO<sub>2</sub> detector principal of operation is based on the Venturi effect of the probe that extends into the HVAC duct. Air flowing through the duct is forced into the vent holes on one side of the probe, into the enclosure, over the CO<sub>2</sub> sensor and then is drawn back out of the enclosure via the probe vent holes on the opposite side.

**NOTE:** to ensure proper humidity and temperature readings, the RH/T inlet on the probe must be installed directly toward the airflow See Figure 1.

Drill or punch a 7/8" or 1" hole in the duct at the preferred location and insert the probe into the hole to mark the enclosure mounting holes. Remove the unit and drill the two mounting holes. Clean all drilled holes of debris before mounting the device.

Mount the enclosure to the duct with two sheet metal screws such that the duct air flow is parallel with the vent holes in the probe (i.e.: air flows directly into the probe holes). To prevent air leaks, ensure the gasket is compressed around the probe between the device enclosure and the air duct.

The enclosure has a hinged cover with a latch. Open the cover by pulling slightly on the latch on the bottom of the enclosure, at the same time pulling on the cover, as illustrated in Figure 2.

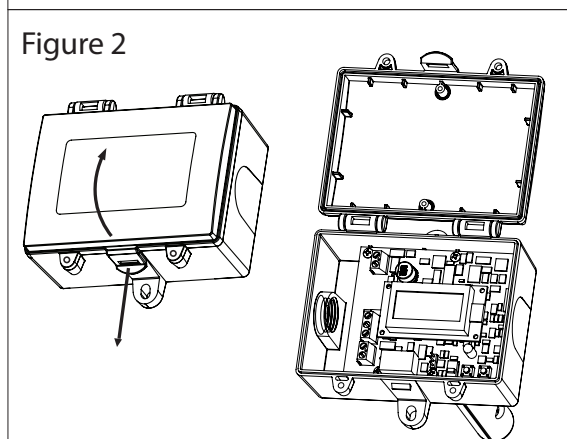
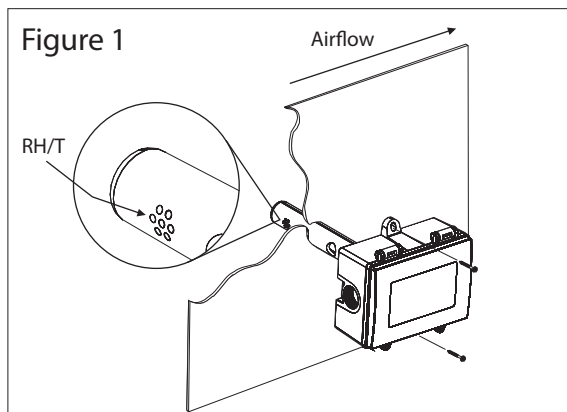

A 1/2" NPT threaded connection hole is provided in the left side of the enclosure. Screw the EMT connector or cable gland connector in until tight. See Figure 3. It is recommended that weatherproof conduit or cable gland fittings be used. The F style enclosure includes a 1/2" NPT to M16 thread adapter and cable gland fitting. Insert the provided foam plug in the EMT opening to prevent air from entering the enclosure through the EMT.

Make wiring connections as per the "Wiring" illustrations on Page 2.

Swing door closed until securely latched. For added security, 2 screws are provided that may be installed in the integrated screw tabs. See Figure 4.

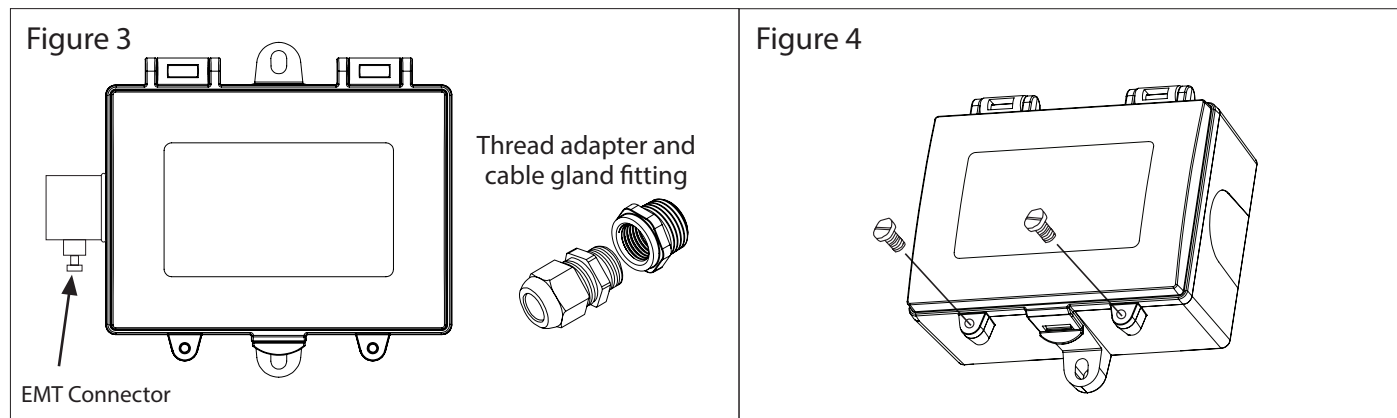

## WIRING

- Deactivate the 24 Vac/dc power supply until all connections are made to the device to prevent electrical shock or equipment damage.
- Use 14-22 AWG shielded wiring for all connections and do not locate the device wires in the same conduit with wiring used to supply inductive loads such as motors. Make all connections in accordance with national and local codes.
- Pull at least six inches of wire into the enclosure, then complete the wiring connection according to the wiring diagram for the applicable power supply and output signal type.
- Connect the plus DC or the AC voltage hot side to the Power terminal. For voltage output or AC power, the supply Common is connected to the Common terminal. The device is reverse voltage protected and will not operate if connected backwards. It has a half-wave power supply so the supply Common is the same as the signal Common. See Figure 5.
- The voltage model is selectable for either 0-5 or 0-10 Vdc via the menu (the factory default is 0-5 Vdc). See Figure 5.

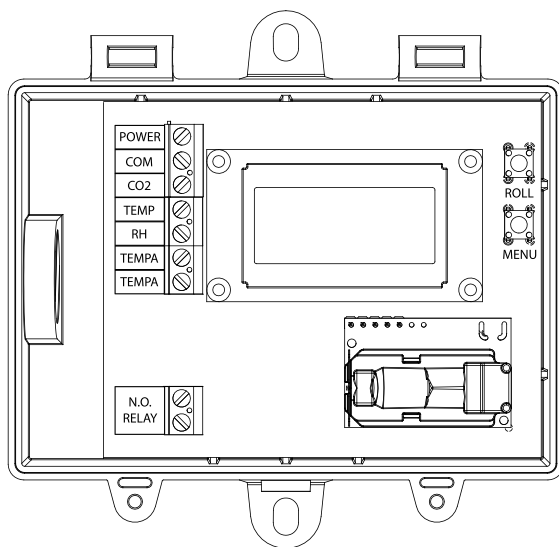
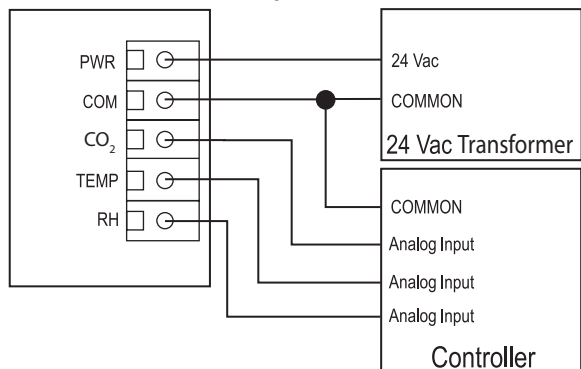
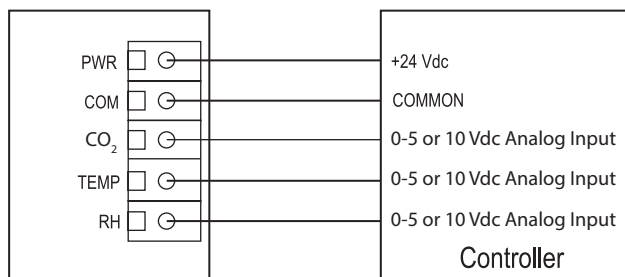

Figure 5

### Wiring for all output signals and external 24 Vac power transformer



### Wiring for voltage output signal and 24 Vdc power from controller



- The optional relay output connects to the RELAY terminals. The relay output is completely isolated and has a Normally Open (NO) signal. This signal can be used to directly control an alarm or ventilation fan. See specifications for contact ratings. See Figure 6.
- The optional two-wire temperature sensor output is available with various RTDs and thermistors to suit all control applications and is available on the TEMP terminals. See Figure 7.

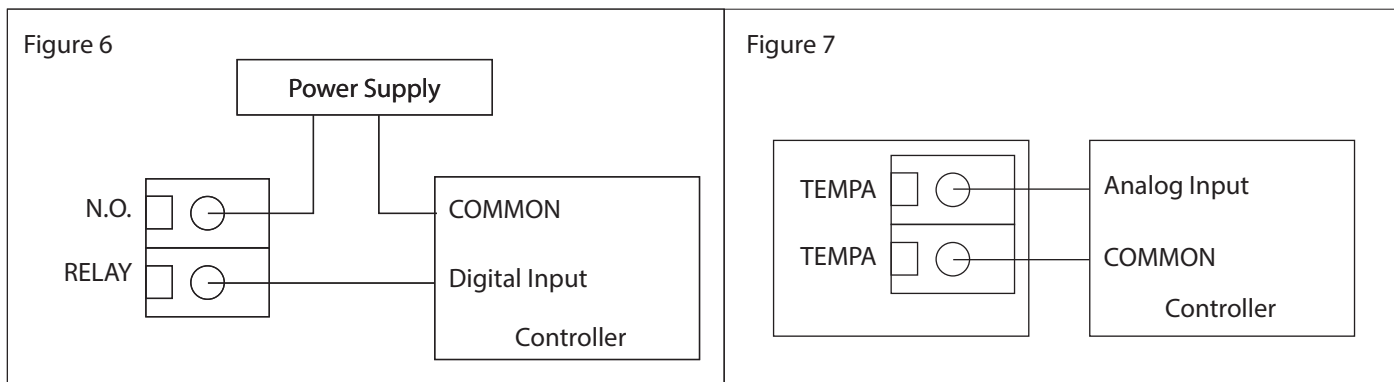

## OUTPUTS

The CO<sub>2</sub> output is scaled so that 4-20 mA (or 0-5/0-10Vdc) equals 0 to Out\_High as set in the Setup menu. The factory default is 0-2000 ppm, and can be adjusted between 0-1000ppm and 0-10,000. The Out\_High can be changed in the Setup menu and the output signal is scaled accordingly. The RH and temperature outputs operate similar to the CO<sub>2</sub> output. RH is scaled 0-100 %RH and temperature defaults to 0 to 50°C but can be changed to 0 to 35 °C, 32 to 95°F or 32 to 122 °F using the Setup Menu. For voltage output models, the factory default is 0-5 Vdc and can be changed to 0-10 Vdc in the Setup Menu.

## OPERATION

The CO<sub>2</sub>, RH and Temperature signals are connected to the BAS analog inputs. The BAS reads the voltage or current signals and calculates actual values using correct scaling for the ranges and signal type. These values can be used to control ventilation devices or initiate alarms. All values are displayed locally on the LCD. The Setup Menu can be used to modify the displayed information. The display is factory set to display all three measurement values. The CO<sub>2</sub> level will be displayed as 0-2000 ppm, the %RH will be displayed as 0-99H and the temperature will be displayed as 0 to 50°C. The Setup menu can be used to modify the displayed information. The installer can select to only display CO<sub>2</sub>, or to display CO<sub>2</sub> and RH, or alternately CO<sub>2</sub> and temperature. The device supports four temperature ranges that may also be selected in the menu.

The default is 0 to 50°C but this may be changed to 0-35°C and the the output scaling will change. Also, the temperature range may be changed to 32 to 122°F or 32 to 95°F and output signal will stay the same to match the display.

## USER MENU

The User Menu has several items as shown below. To enter the menu, press and release the <MENU> key while in normal operation. This will enter the User Menu step 1, pressing the <MENU> key a second time advances to step 2. Each press of the <MENU> key saves the selection and advances the menu item. The <ROLL> key is used to make changes to program variables by scrolling through the available options.

NOTE: If no keys are pressed for 5 minutes, the menu will automatically exit.

<MENU> Press and release to enter the setup menu.

**Out High**  
2000 ppm

The default CO<sub>2</sub> range is 0-2000 ppm. The output span can be changed from 1000 to 10000 ppm in increments of 500. Use <ROLL> to change the value.

<MENU> Press to advance to next menu item

**Auto Cal**  
ON

Automatic Cal Mode default is ON to correct CO<sub>2</sub> sensor drift to better than ±10 ppm per year. ON is recommended for applications where the CO<sub>2</sub> level will be close to normal (400 ppm) at least once per day. If a building is occupied 24 hours and the CO<sub>2</sub> level is fairly constant then the Auto Cal feature should be turned off. Turning off the Auto Cal feature will require the device to be calibrated annually.

<MENU> Press to advance to next menu item

*Altitude*  
*0 ft*

The default is 0 meter. Change by using <ROLL> from 0 to 2550 meters in 500 meter increments for CO<sub>2</sub> local altitude correction.

<MENU> Press to advance to next menu item

*Temp C/F*  
*°C*

The temperature scale defaults to Celsius (°C). Use <ROLL> to change to Fahrenheit (°F).

<MENU> Press to advance to next menu item

*T Range*  
*0-50 °C*

Two temperature ranges are available for output scaling, 0-35°C (32-95°F) or 0-50°C (32-122°F). Change using <ROLL>. The available range will depend on the °C or °F menu selection.

<MENU> Press to advance to next menu item

*T Offset*

This item allows calibration of the temperature sensor. Use <ROLL> to add an offset to 0°C the temperature signal and display. -1 subtracts 1 degree from the temperature and +1 adds 1 degree to the temperature. The range is -5 to +5°C or -10 to +10°F. Resolution is 0.5°C or 1°F. Units depend on the previous C/F setting and resets to 0° if C/F is changed.

<MENU> Press to advance to next menu item

*RH Offset*

This item allows calibration of the RH sensor. Use <ROLL> to add an offset to the RH 0 %RH signal and display. -1 subtracts 1 %RH and +1 adds 1 %RH. The range is -10 to +10 %RH.

<MENU> Press to advance to next menu item

### ***For models with the relay option installed***

*Relay SP*  
*1000 ppm*

The relay trip setpoint default is 1000 ppm. Use <ROLL> to change from 500 to 9000 in 100 ppm increments.

<MENU> Press to advance to next menu item

*Relay Hy*  
*50 ppm*

The relay hysteresis default is 50 ppm. Use <ROLL> to change from 25 to 500 in 25 ppm increments.

<MENU> Press to advance to next menu item

*Relay*  
*On Delay*

The relay on delay time default is 0 minutes. Use <ROLL> to change from 0 to 9 minutes in 1 minute increments.

<MENU> Press to advance to next menu item

*Relay*  
*Test OFF*

Use <ROLL> to toggle the relay ON or OFF for testing purposes.

<MENU>

Press to advance to next menu item

**For models with the voltage output only**

Out Type  
0-5 Vdc

The default output type is 0-5 Vdc. Use <ROLL> to change to 0-10 Vdc if necessary.

<MENU>

Press to advance to next menu item

Calibrat  
1000 ppm

This item is used for 1000 ppm gas calibration and is explained in the *Calibration* section.

<MENU>

Press to advance to next menu item

BackLite  
Auto

Use <ROLL> to enable, disable, or set to auto the LCD backlight. When enabled the LCD backlight is always on, when disabled it never lights, and if set to auto it lights for a time period of 30 seconds whenever a key is pressed. The factory default is Auto.

<MENU>

Press to exit the menu and return to normal operation.

**CALIBRATION**

The RH and temperature measurements typically do not need any calibration for the life of the product. Both values may have user offsets assigned in the Setup Menu.

Calibration with gas requires a field calibration kit with pressure regulator, sensor hood, necessary tubing and appropriate bottles of CO<sub>2</sub> gas. The device requires only a single point 1000 ppm calibration to meet specified accuracy due to the Automatic Calibration mode and other technology incorporated into the model.

Turn the regulator knob off and connect the 1000 ppm CO<sub>2</sub> gas bottle and hand tighten. Remove the cover of the unit to be calibrated to expose the gas sensor chamber. The tubing from the gas bottle can be connected to either port on the chamber after the plastic cap is removed. Gently remove one cap and connect the tubing, note that strong shock or vibration can affect calibration. The CO<sub>2</sub> reading on the LCD will begin to approach 1000 ppm. Wait 1 to 2 minutes until the CO<sub>2</sub> reading stabilizes.

Enter the Setup menu and use the <MENU> key to advance to Calibrat 1000 PPM. Press and hold the <SAVE> key for 2 seconds. When calibration is complete the unit will display the ppm value and Cal Done. Press the <SAVE> key to return to normal operation and shut the gas off.

Disconnect the tubing and replace the cap on the sensor chamber as calibration is complete.

**DIMENSIONS**

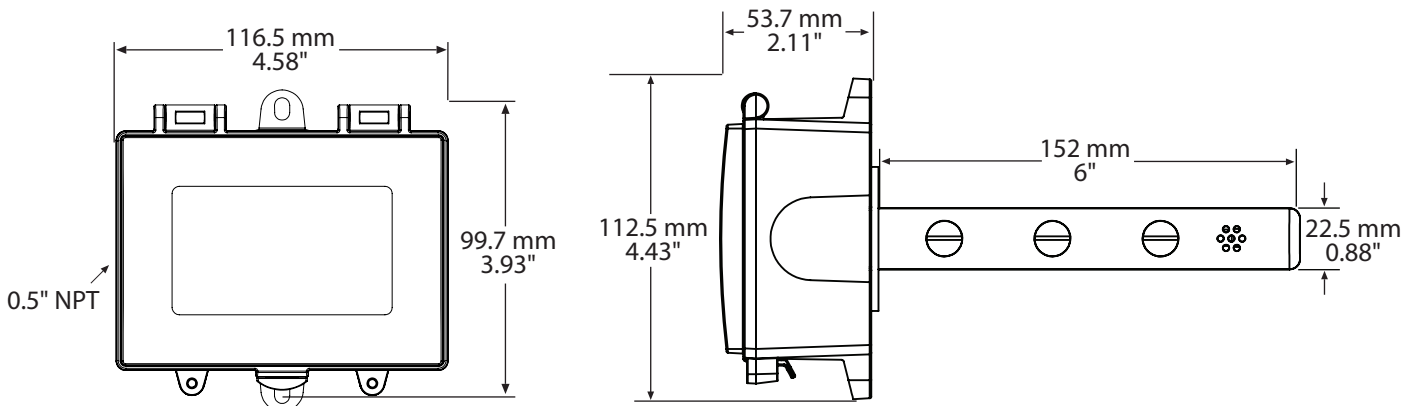

## **SPECIFICATIONS:**

### **CO2 SENSOR**

Measurement Type .....Non-Dispersive Infrared (NDIR), dual channel, diffusion sampling  
Measurement Range.....0-2000 ppm default, adjustable between 0-1000 ppm and 0-10,000ppm  
Standard Accuracy .....±30ppm +3% of reading (with Auto-cal)  
Temperature Dependence .....±2.5ppm/ °C  
Altitude Correction .....Programmable from 0-2550 m via keypad  
Response Time.....20 seconds  
Warm-up Time .....1 minute  
Sensor Life Span.....>15 years

### **RH SENSOR**

Accuracy.....±2 %RH  
Range .....0-100 %RH, non-condensing  
Resolution .....2 %RH  
Hysteresis.....±0.8 %RH  
Response Time.....8 seconds typical  
Long Term Drift..... <0.25%RH/year

### **TEMPERATURE SENSOR**

Range .....0 to 35°C (32 to 95°F) or 0 to 50°C (32 to 122°F) selectable via keypad  
Accuracy.....±0.2°C  
Resolution .....0.1°C

### **OPTIONAL PASS-THRU TEMPERATURE SENSOR**

Type.....Thermistor or RTD  
Accuracy.....Thermistors: ±0.2°C (±0.36°F) @ 25°C (77°F)  
Platinum RTD's: ±0.3°C (±0.54°F) @ 0°C (32°F)  
Nickel RTD's: ±0.4°C (±0.72°F) @ 0°C (32°F)  
Output .....2-wire resistive

### **GENERAL SPECIFICATIONS**

Power Supply .....20 - 28 Vac/dc (non-isolated half-wave rectified)  
Consumptions .....Current - 120 mA max @ 24 Vdc, 212 mA max @ 24 Vac  
Voltage - 79 mA max @ 24 Vdc, 129 mA max @ 24 Vac  
Output Signals.....4-20 mA active (sourcing) or 0-5 Vdc / 0-10 Vdc (field selectable)  
Output Drive Capability.....Current - 550 ohm maximum  
Voltage - 5 Kohm minimum  
Operating Conditions.....0-50°C (32-122°F), 0-95 %RH non-condensing  
Enclosure .....Polycarbonate, UL94-V0, IP65 (NEMA 4X)  
116.5mm x 99.7mm x 53.7mm (4.6" x 3.9" x 2.1")  
Storage Temperature .....-20 to 60°C (-4 to 140°F)  
Probe .....152 mm L x 22.5 mm D (6" x 0.85")

### **OPTIONAL RELAY**

Contact Ratings.....Form A contact (N.O.), 2 Amps @ 140 Vac, 2 Amps @ 30 Vdc  
Relay Trip Point.....Programmable 500 to 9000 ppm in 100 ppm increments.  
Default is 1000 ppm  
Relay Hysteresis.....Programmable 25 to 500 ppm in 25 ppm increments. Default is 50 ppm  
Relay Delay.....Programmable 0 to 9 minutes in 1 minute increments.  
Default is 0 minutes  
Approvals.....CE  
Country of Origin.....Canada