

INTRODUCTION

The CO2 sensor series uses a highly accurate and reliable non-dispersive infrared (NDIR) sensor in an attractive, duct mount enclosure to monitor return air CO2 levels for indoor applications. The compact dual wavelength CO2 sensor achieves excellent performance characteristics, including high accuracy and low power consumption to ensure stable long term operation. The device is also available with an optional resistive temperature sensor.

BEFORE INSTALLATION

Read these instructions carefully before installing and commissioning the device. Failure to follow these instructions may result in product damage. Do not use in an explosive or hazardous environment, with combustible or flammable gases, as a safety or emergency stop device or in any other application where failure of the product could result in personal injury. **Take electrostatic discharge precautions during installation and do not exceed the device ratings.**

MOUNTING

The CO2 duct type sensor installs on the outside of a return air duct with the sampling tube inserted into the duct. Mount the sensor in an easily accessible location in a straight section of duct at least five feet from corners and other items that may cause disturbances in the air flow. Avoid areas where the detector is exposed to vibrations or rapid temperature changes. See Figure 1.

The duct CO2 sensor principal of operation is based on the venturi effect of the probe that extends into the HVAC duct. Air flowing through the duct is forced into the vent hole on one side of the probe, into a sealed chamber within the enclosure, over the CO2 sensor and then air is drawn back out of the enclosure via the vent holes on the opposite side of the probe.

Drill or punch a 7/8" or 1" hole in the duct at the preferred location and insert the probe into the hole to mark the enclosure mounting holes. Remove the unit and drill the two mounting holes. Clean all drilled holes of debris before mounting the device. Mount the enclosure to the duct with two sheet metal screws such that the duct air flow is parallel with the vent holes in the probe (i.e.: air flows directly into the probe holes). To prevent air leaks, ensure the gasket is compressed around the probe between the device enclosure and the air duct.

The enclosure has a hinged cover with a latch. Open the cover by pulling slightly on the latch on the bottom side of the enclosure and at the same time pulling on the cover, as illustrated in Figure 2.

A 1/2" NPT threaded connection hole is provided in the left side of the enclosure. Screw the EMT connector or cable gland connector in until tight. See Figure 3. It is recommended that weatherproof conduit or cable gland fittings be used. The F style enclosure includes a 1/2" NPT to M16 thread adapter and cable gland fitting.

Two security screws are provided which can be installed to help secure the cover once settings and wiring connections are complete. See Figure 4.

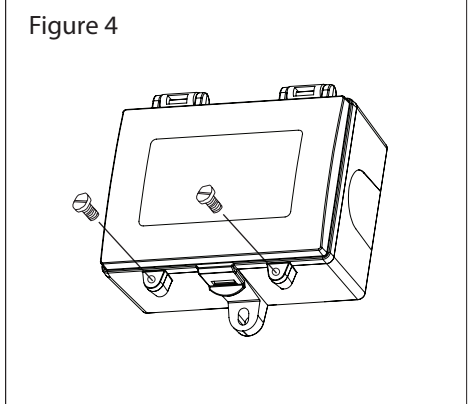
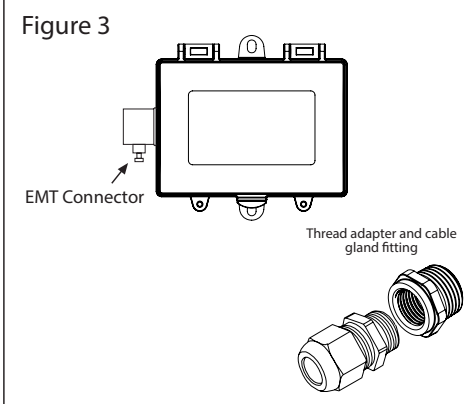
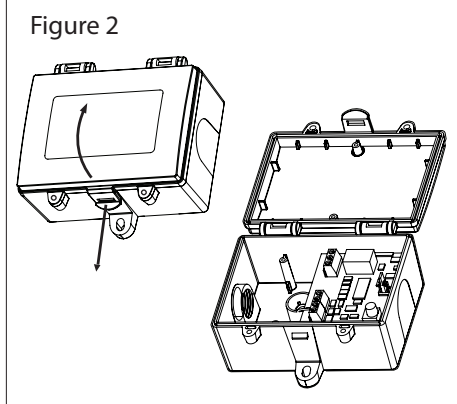
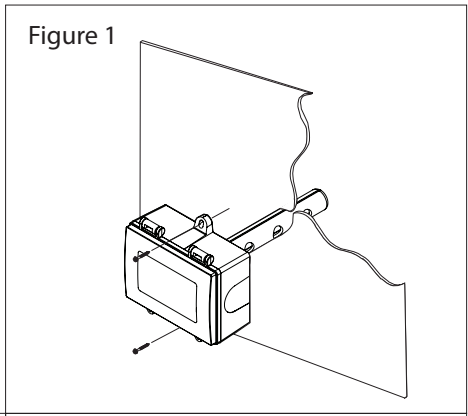

WIRING

Deactivate the 24 Vac/dc power supply until all connections are made to the device to prevent electrical shock or equipment damage. Follow proper electrostatic discharge (ESD) handling procedures when installing the device or equipment damage may occur. Use 22 AWG shielded wiring for all connections and do not locate the device wires in the same conduit with wiring used to supply inductive loads such as motors. Make all connections in accordance with national and local codes.

This is a 3-wire sourcing device. Connect the plus dc or the ac voltage hot side to the POWER terminal. The supply common is connected to the COMMON terminal. The device is reverse voltage protected and will not operate if connected backwards. It has a half-wave power supply so the supply common is the same as the signal common. Several devices may be connected to one power supply and the output signals all share the same common. Use caution when grounding the secondary of a transformer or when wiring multiple devices to ensure the ground point is the same on all devices and the controller.

The analog output is available on one of the CO2 terminals. Either the mA or VOLT output terminal may be used (but not both at the same time). This signal is used for either voltage or 4-20 mA active output as shown in Figure 5. In voltage mode the output is selectable for either 0-5 or 0-10 Vdc using the PCB jumper. The current output operates in the active mode and does not require a loop power supply (the signal current is generated by the transmitter and must not be connected to a powered input or device damage will result).

Check the controller Analog Input to determine the proper connection before applying power. Both current and voltage signals are referenced to the COMMON terminal. The analog output signal is typically connected directly to the Building Automation System (B.A.S.) and used as a control parameter or for logging purposes.

The two-wire temperature sensor output is available with various RTDs and thermistors to suit all control applications and is available on the TEMP SENSOR terminals as shown in Figure 5.

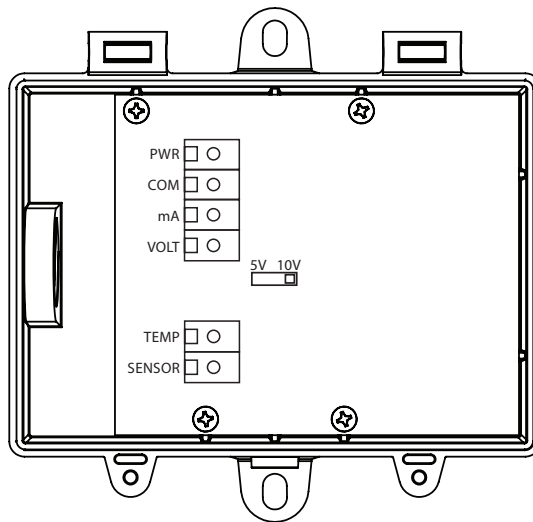
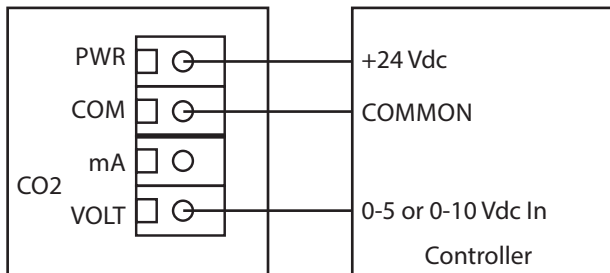
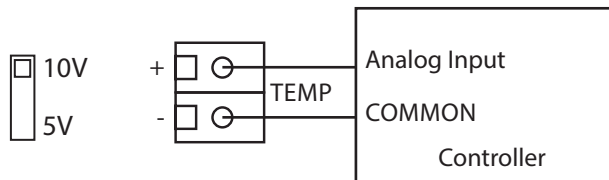
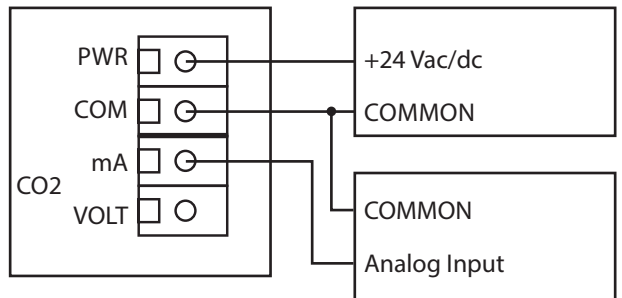

Figure 5

Wiring for voltage output signal and 24 Vdc power from controller



Wiring for 4-20 mA output and external 24 Vac power transformer or power supply



OPERATION

The output signal is available on one of the CO2 terminals and is connected to the BAS analog input which reads the signal and calculates the CO2 ppm value using correct scaling for the range and signal type. The CO2 value is used to control output ventilation devices or initiate alarms.

If an optional temperature sensor is installed it will be wired to an analog input of the BAS that is set for the specific resistance type. This could be a 10K thermistor, a 1000 ohm RTD or other sensor values. The BAS reads the resistance signal and converts it to a temperature value.

The device includes a red LED on the PCB to indicate correct operation. In warm-up mode (the first 1 minute after power is applied), the LED blinks at 2 times per second. After the warm-up period the LED will blink once every 4 seconds to indicate normal operation. If the CO2 level is above the maximum scale (over-range), then the LED will blink once per second.

CALIBRATION

Every sensor is factory calibrated and will achieve stable long term operation due to using dual IR detectors and proprietary signal processing technology. The duct CO2 sensor is designed for simple integration into any BAS system and for long term trouble free operation. As such, field calibration is not available or recommended on the product.

OUTPUT SIGNAL

The CO2 output is scaled such that 4-20 mA or 0-5 Vdc or 0-10 Vdc equals 0 to 2000 ppm.

For 4-20 mA output type, connect the mA output terminal to the controller analog input. The COMMON terminal is the signal reference. Typically, this type of input would have a 250 ohm input impedance.

If using voltage output type, connect the VOLT output terminal to the controller analog input. The COMMON terminal is the signal reference. Typically, this type of input would have a high impedance > 10 Kohms. The VOLT output signal can be scaled as 0-5 or 0-10 Vdc by changing the jumper position on the PCB.

SPECIFICATIONS

SENSOR

CO2 Sensor Dual wavelength non-dispersive infrared (NDIR)
Range..... 0-2000 ppm
Accuracy ± (50 ppm + 3% of reading)
Sensor Life Span..... >10 years

OUTPUT

Output Signals4-20 mA, 0-5 Vdc, 0-10 Vdc (field selectable)
Drive Capability**Current:** 600 Ω max @ 24 Vdc
Voltage: 10K Ω min

POWER SUPPLY

Power Supply.....24 Vac/dc ± 20% (non-isolated half-wave rectified)
Consumption.....80 mA max @ 24 Vdc, 160 mA max @ 24 Vac
Protection.....Reverse voltage and transient protected

OPTIONS

Optional Temperature Sensor....Various RTDs or thermistors as a 2-wire resistance output

GENERAL

Probe152 mm L x 21.6 mm Diameter (6" x 0.85")
Enclosure Material.....Polycarbonate, UL94-V0, IP65 (NEMA 4X)
Enclosure Dimensions.....112 mm W x 117 mm H x 53 mm D (4.4" x 4.6" x 2.1")
Warm-up Time.....1 minute
Pressure Dependency..... <1% of reading / kPa
Operating Conditions.....-10 to 50°C (14 to 122°F), 0-90 %RH non-condensing
Storage Conditions.....-30 to 70°C (-22 to 158°F), 0-85 %RH non-condensing
Wiring Connections.....Screw terminal block (14-22 AWG)
Approvals.....CE, RoHS
Country of Origin.....Canada

DIMENSIONS

