

INTRODUCTION

Indoor air quality has been equated to CO2 levels for Demand Controlled Ventilation (DCV) applications in an effort to improve building health and reduce energy costs. The benefits of healthy and "green" buildings are well known today and progress in controlling ventilation rates to optimum values is still being made. One area that has received significant study and attention is the measurement of indoor air quality pollutants.

The traditional measurement of CO2 levels is often seen as limiting when compared to the total amount of volatile organic compounds (VOCs) present in the air that have a detrimental effect on the human perception of air quality. These indoor VOCs

are hydrocarbons that originate mainly from bio-effluents (odors from human respiration, perspiration and metabolism) and vapors generated from building materials and furnishings. There are thousands of unique VOCs that may be present in indoor air that affect the air quality. The table below (Figure 1) lists some of the more common VOCs and their source.

Figure 1 Typical Indoor Air VOC Contaminants		
Contamination Source	Emission Source	VOCs
Human Being	Breath Skin Respiration and Perspiration Flatus Cosmetics Household Supplies Combustion	Acetone, Ethanol, Isoprene Nonanal, Decanal, a-Pinene Methan, Hydrogen Limonene, Eucalyptol Alcohols, Esters, Limnene Unburnt Hydrocarbons
Office Equipment Building Material Furniture Consumer Products	Printers, Copiers, Computers Paint, Adhesive, Solvent, Carpet PVC (Poly Vinyl Chloride)	Benzene, Styrene, Phenole Formaldehyde, Alkanes, Aldehydes, Ketones Toluene, Xylene, Decane

It is generally understood that the root cause of indoor air quality problems lies with the presence of these VOCs. Unfortunately, it has been difficult to accurately measure VOCs due to the lack of suitable VOC sensing devices. Early VOC sensors suffered from long-term stability problems, drift and an output signal that was difficult to define and apply in a reliable way.

CO2 sensors have long served as an adequate air quality indicator with a defined range ppm output signal that is easy to set thresholds to. The American Society of Heating, Refrigeration and Air-Conditioning Engineers (ASHRAE) Standard 62.1 (Ventilation for Acceptable Indoor Air Quality) is generally used in DCV applications because minimum ventilation rates are clearly defined based on occupancy and CO2 sensors are then generally used to determine occupancy.

This system has worked for DCV system designers due to it's straight-forward design, predictable results and energy saving results. However, the control of indoor air quality based on CO2 levels alone is not optimal because it ignores other air contaminants that are often present. Ventilation should react on demand toward all sources of contamination, not only CO2.

THE IAQ SENSOR

The Indoor Air Quality Sensor uses an advanced MEMS metal oxide semiconductor sensor to detect poor air quality. The sensor reacts quickly to detect a broad range of VOCs such as smoke, cooking odors, bio-effluence, outdoor pollutants and from human activities. The sensor captures all VOC emissions that are completely invisible to CO2 sensors.

Extensive studies and research have shown that there is direct correlation between CO2 levels and VOC levels and the Air Quality Sensor has been calibrated to provide a "CO2-equivalent" ppm measurement value, thereby achieving full compatibility to existing HVAC CO2 ventilation standards. The sensor also includes control algorithms that correct sensor drift and aging and therefore provides a long-term consistent DCV solution while overcoming the deficiencies of CO2 measurement by detecting the true root-cause of ventilation demand, VOCs. The IAQ sensor emulates the human perception of air quality much more than a CO2 sensor and even detects odorless, potentially hazardous substances such as carbon monoxide.

The CO₂-equivalent sensor output value was developed over a period of several years to allow the IAQ sensor to be optimized for Demand Controlled Ventilation applications. The long-term IAQ sensor performance was monitored in various locations including offices, cafeterias, schools, production facilities, apartments and homes in direct comparison to infrared-absorption CO₂ sensors. The data shows consistent results between measured CO₂ values and the IAQ CO₂-equivalent values and also highlight the poor air quality events detected by the IAQ sensor that the CO₂ sensor misses. A sample chart showing CO₂ measurements vs. IAQ measurements is shown in Figure 2.

IAQ SENSOR FEATURES

- Measures total VOCs
- Direct correlation to CO₂ levels
- High sensitivity and fast response
- Stable long-term operation
- 0 to 2000 ppm CO₂ output signal
- LCD to display air quality information
- Internal menu for easy setup
- Analog stepped output for damper control
- Linear output for logging and control
- Selectable 0-5 or 0-10 Vdc signal
- Relay output with adjustable setpoint
- Optional resistive temperature sensors

BEFORE INSTALLATION

Read these instructions carefully before installing and commissioning the transmitter. Failure to follow these instructions may result in product damage. Do not use in an explosive or hazardous environment, with combustible or flammable gases, as a safety or emergency stop device or in any other application where failure of the product could result in personal injury. **Take electrostatic discharge precautions during installation and do not exceed the device ratings.**

NOTE 1: The air quality sensor requires a continuous burn-in time of at least 3 weeks before the sensor algorithms provide accurate measurements. During this period the product-to-product readings may show large variations. The sensor may also indicate very high ppm readings during the initial burn-in phase.

NOTE 2: The air quality sensor is meant to provide an accurate measurement of INDOOR air quality. Diesel exhaust is not a component of indoor air quality and the sensor should not be used in such an application.

MOUNTING

The duct type sensor installs on the outside of a return air duct with the sampling tube inserted into the duct. Mount the sensor in an easily accessible location in a straight section of duct at least five feet from corners and other items that may cause disturbances in the air flow. Avoid areas with vibrations or rapid temperature changes.

The duct sensor principal of operation is based on the Venturi effect of the probe that extends into the HVAC duct. Air flowing through the duct is forced into the vent holes on one side of the probe, over the air quality sensor and then is drawn back out of the probe vent holes on the opposite side.

Drill or punch a 7/8" or 1" hole in the duct at the preferred location and insert the probe into the hole to mark the enclosure mounting holes. Remove the unit and drill the two mounting holes. Clean all drilled holes of debris before mounting the device. Mount the enclosure to the duct with two #10 sheet metal screws (not included) such that the duct air flow is parallel with the vent holes in the probe (i.e.: air flows directly into the probe holes). To prevent air leaks, ensure the gasket is compressed around the probe between the device enclosure and the air duct. As shown in Figure 1.

The enclosure has a hinged cover with a latch. Open the cover by pulling slightly on the latch on the bottom side of the enclosure and at the same time pulling on the cover, as illustrated in Figure 4.

A 1/2" NPT threaded connection hole is provided in the left side of the enclosure. Screw the EMT connector or cable gland connector in until tight. See Figure 5. It is recommended that weatherproof conduit or cable gland fittings be used. The F style enclosure includes a 1/2" NPT to M16 thread adapter and cable gland fitting.

Two security screws are provided which can be installed to help secure the cover once settings and wiring connections are complete. See Figure 6.

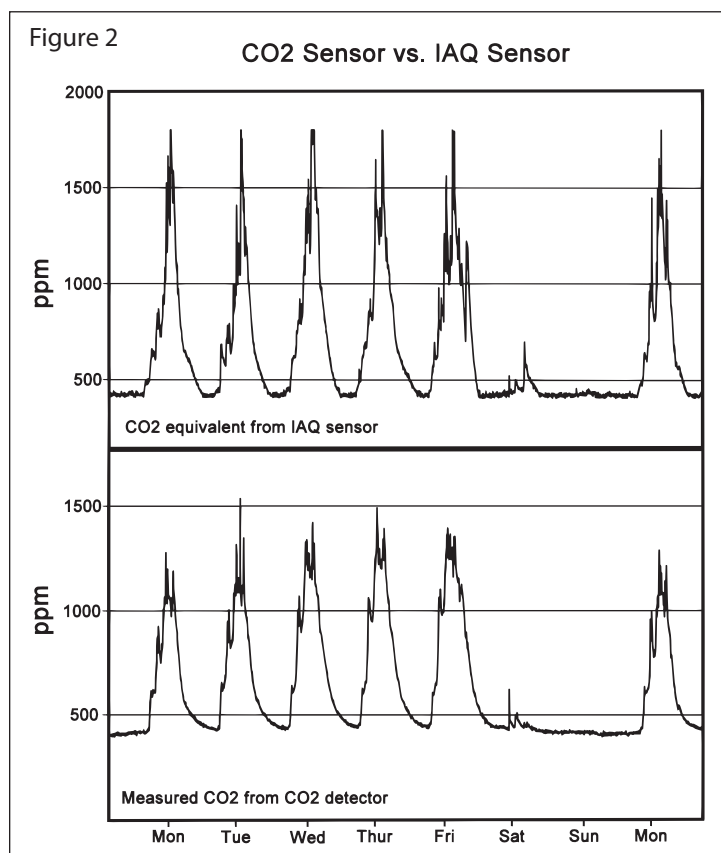

Figure 3

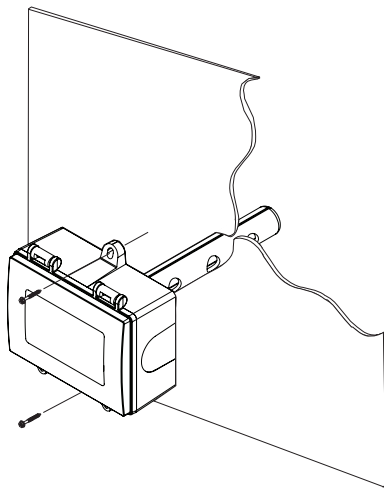

Figure 4

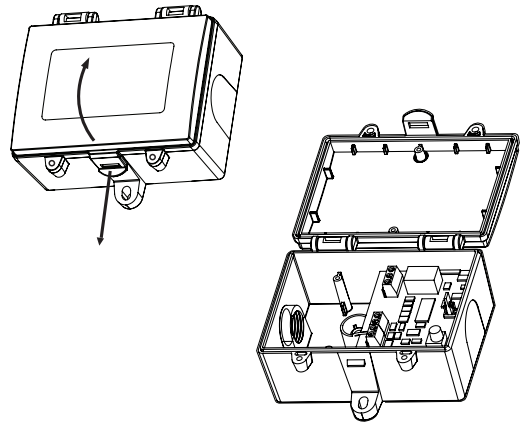

Figure 5

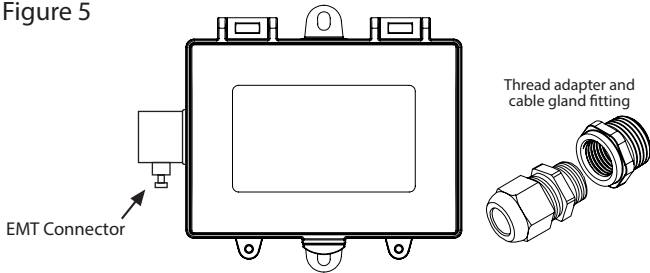
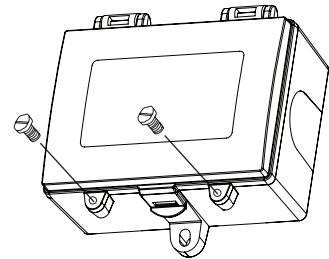

Figure 6



WIRING

- Deactivate the 24 Vac/dc power supply until all connections are made to the device to prevent electrical shock or equipment damage. Follow proper electrostatic discharge (ESD) handling procedures when installing the device or equipment damage may occur
- Use 18-22 AWG shielded wiring for all connections and do not locate the device wires in the same conduit with wiring used to supply inductive loads such as motors. Make all connections in accordance with national and local codes.
- Connector layout is shown in Figure 7. Diagram shown includes all options. If option is not ordered, connector will not be present.
- Connect the positive DC voltage or the hot side of the AC voltage to the terminal marked POWER. The power supply common is connected to the terminal marked COMMON as shown in Figure 8.
- The device is reverse voltage protected and will not operate if connected backwards.

Figure 7

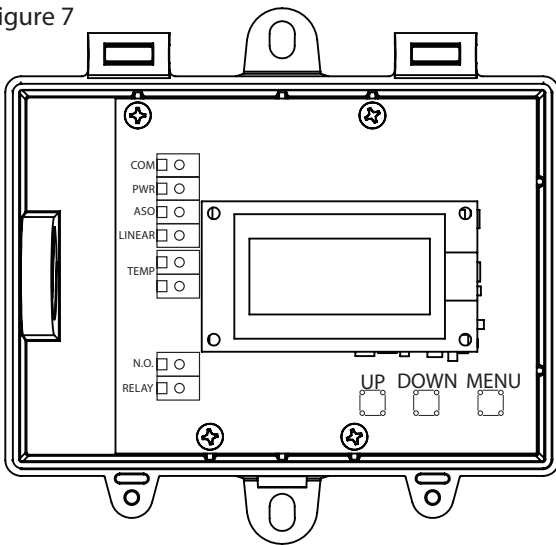

This device has a half-wave type power supply so the power supply common is the same as the output signal common. Therefore, several devices may be connected to one power supply and the output signals all share the same signal common. Use caution when grounding the secondary of an AC transformer or when wiring multiple devices to ensure that the circuit ground point is the same on all devices and the controller.

Figure 8

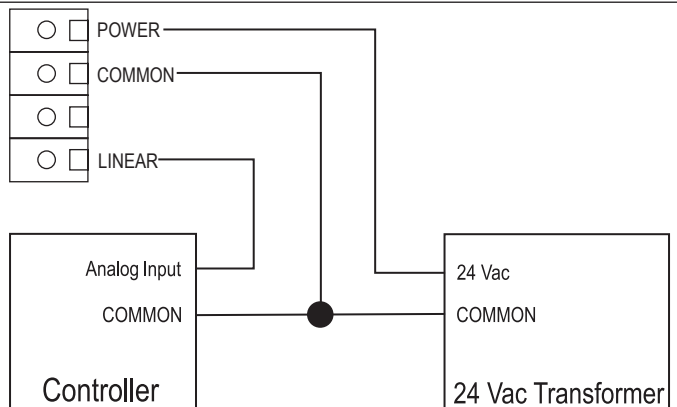
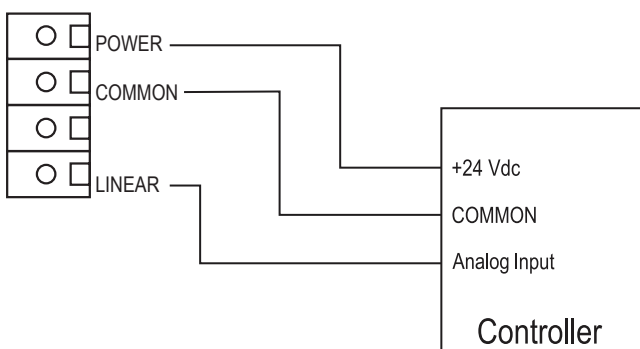

Ensure the controller Analog Input (AI) matches the IAQ voltage output signal type before power is applied. The voltage signals have a minimum load rating. Follow the ratings in the Specification section or inaccurate readings may result.

Connect the LINEAR output signal to a 0-5 or 0-10 Vdc analog input port on the controller as shown in Figure 8. The device is factory configured for 0-5 Vdc output signal but may be changed to 0-10 Vdc via the menu. Changing output signal may be done during set up of the device. This linear output signal represents to 0-2000 ppm CO₂-equivalent value.

The ASO (Analog Stepped Output) output signal is a second voltage signal that represents the three air quality levels of GOOD, FAIR, and POOR. Each level may be set independently via the menu to any value between 0 and 10 Vdc. The factory default is GOOD = 2.5 V, FAIR = 5.0 V, and POOR = 7.5 V. This signal can also be connected to a controller analog input, or it can be connected directly to a 0-5 or 0-10 Vdc input of a damper actuator for direct ventilation control as shown in Figure 9. In this way, the Indoor Air Quality Sensor can be used as a stand-alone device. Since all steps are completely adjustable, the device can also drive a reverse acting actuator.

The relay output available on the RELAY terminals. The relay output terminals are completely isolated from other connections and are NOT connected to the signal COMMON terminal as shown in Figure 10. This signal can be used to directly control an alarm, a ventilation fan or may be connected to a digital input of a Building Automation System for status monitoring. Respect the relay contact specification as listed on Page 6.

An optional resistive temperature sensor may also be included in the device and is connected to the TEMP terminals as shown in Figure 11. Various thermistors or RTDs may be installed on the PCB to suit the application. These terminals would connect to a thermistor or RTD sensor input on the controller.

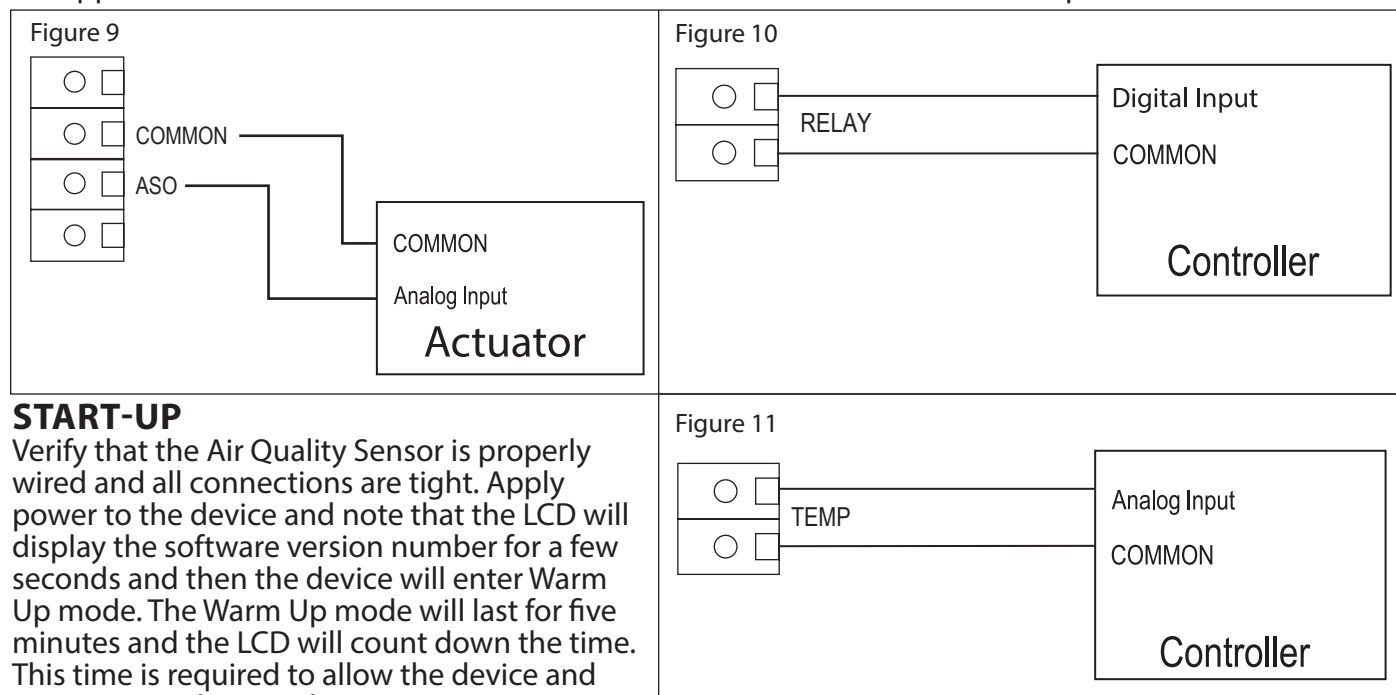

START-UP

Verify that the Air Quality Sensor is properly wired and all connections are tight. Apply power to the device and note that the LCD will display the software version number for a few seconds and then the device will enter Warm Up mode. The Warm Up mode will last for five minutes and the LCD will count down the time. This time is required to allow the device and sensor to reach normal operating temperature.

After the five minutes has expired the device will enter normal operation and the LCD will indicate the IAQ status and ppm value.

OPERATION

In normal operation, the Air Quality Sensor will detect a broad range of reducing gases such as CO and VOCs and translate the measurement into a parts per million (ppm) CO₂ equivalent value. This value is displayed on the LCD in either ppm or % as set in the menu. The air quality value is also displayed as either GOOD, FAIR or POOR and these values can also be set via the menu.

The GOOD, FAIR and POOR air quality levels control the Analog Stepped Output (ASO) signal. The ASO output signal comprises of three independently set voltage levels that can be used to directly control a damper actuator for three positions. The levels are set via the menu and each level can be set anywhere from 0-10 Vdc.

The air quality value is also sent to the LINEAR output as a 0-5 or 0-10 Vdc signal to represent the 0-2000 ppm CO₂ equivalent.

This signal can interface to any voltage analog input for logging or control purposes.

The linear output scaling and ASO operation is shown below. Note that the ASO GOOD/FAIR trip level = 1000 ppm and the FAIR/POOR trip level = 1500 ppm. The ASO output levels are GOOD = 2.5 V, FAIR = 5.0 V and POOR = 7.5 V.

Linear Output vs. IAQ ppm

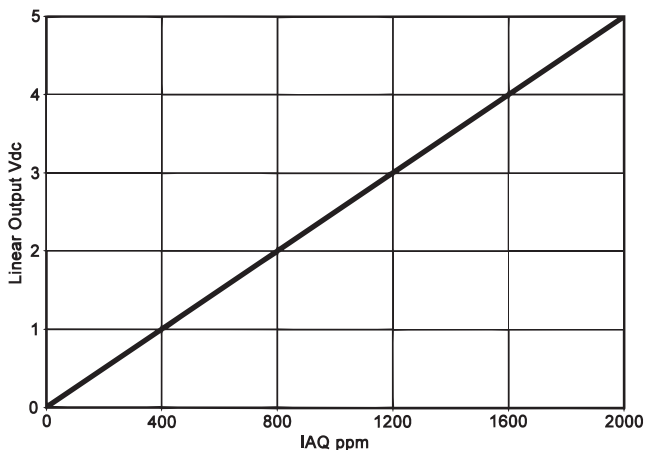

IAQ ppm and ASO Operation

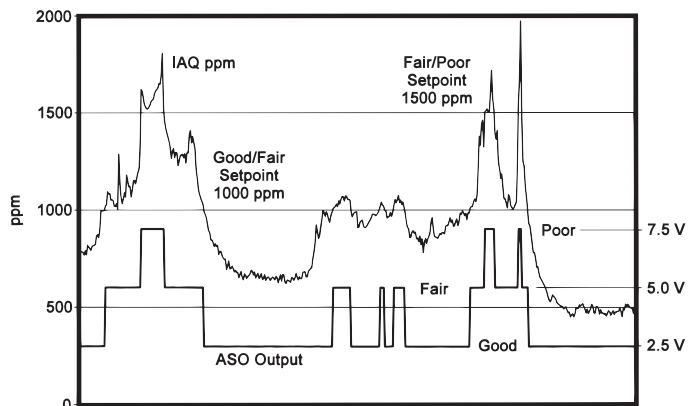

The normally open relay will close when the air quality exceeds a pre-set trip point. The trip point and hysteresis value can be programmed via the menu such that the relay closes when IAQ > Relay Setpoint and opens when IAQ < Relay Setpoint - Hysteresis. By default, the relay has a one minute minimum on and off time to prevent short cycling. This feature may be disabled via the menu. The menu may also be used to test the relay function. The relay can be used to control an alarm, fan directly or to signal a digital input.

Various optional resistive temperature sensors may also be included on the PCB and are available at the TEMP output. This is a two-wire resistive output signal and the temperature value is not displayed on the LCD.

Other features and configurations are described in the Setup Menu section.

NOTE: The air quality sensor requires a continuous burn-in time of at least 3 weeks before the sensor algorithms provide accurate measurements. During this period the product-to-product readings may show large variations. The sensor may also indicate very high ppm readings during the initial burn-in phase.

The air quality sensor is meant to provide an accurate measurement of INDOOR air quality. Diesel exhaust is not a component of indoor air quality and the sensor should not be used in such an application.

MENU

The menu may be accessed any time after the initial warm-up period. The menu is controlled by using the three buttons on the PCB labeled UP, DOWN, and MENU. All values entered are saved in non-volatile memory and will be restored correctly in case of a power failure.

The menu has several items as shown below. To enter the menu, press and release the <MENU> key while in normal operation. This will enter the User menu step 1, pressing the <MENU> key a second time advances to step 2. Each press of the <MENU> key advances the menu item. The <UP> and <DOWN> keys are used to make changes to program variables by scrolling through the available options. When a value is changed, use the <MENU> key to save it to memory and advance to the next menu item. Actual menu displays with the factory default value are shown.

NOTE: If no keys are pressed for 2 minutes, the menu will automatically exit.

<MENU> Press and release to enter the setup menu.

IAQ Unit
ppm

The LCD displays the IAQ sensor reading from 450-2000 ppm. Use <UP> or <DOWN> to change from ppm (default) to % for 0-100% display

<MENU> Press to advance to next menu item

IAQ G/F
1000 ppm

This sets the tip point from Good to Fair IAQ. Factory default is 1000 ppm. Use <UP> or <DOWN> to change from 700 to 1200 ppm in 25 ppm steps.

<MENU> Press to advance to next menu item

IAQ F/P
1500 ppm

This sets the tip point from Fair to Poor IAQ. Factory default is 1500 ppm. Use <UP> or <DOWN> to change from 1300 to 1700 ppm in 25 ppm steps.

<MENU> Press to advance to next menu item

*Analog
Out 5V*

The linear analog output signal defaults to 0-5 Vdc. It can be changed with <UP> or <DOWN> to 0-10 Vdc. The selected scale is equal to 0-2000 ppm.

<MENU> Press to advance to next menu item

*ASO Good
2.5 Vdc*

This sets the ASO output voltage for the Good range. It can be set using <UP> or <DOWN> anywhere from 0-10 Vdc. Resolution is 0.1 Vdc. The ASO output changes accordingly.

<MENU> Press to advance to next menu item

*ASO Fair
5.0 Vdc*

This sets the ASO output voltage for the Fair range. It can be set using <UP> or <DOWN> anywhere from 0-10 Vdc. Resolution is 0.1 Vdc. The ASO out updates.

<MENU> Press to advance to next menu item

*ASO Poor
7.5 Vdc*

This sets the ASO output voltage for the Poor range. It can be set using <UP> or <DOWN> anywhere from 0-10 Vdc. Resolution is 0.1 Vdc. The ASO out updates.

<MENU> Press to advance to next menu item

*IAQ Cal
0 ppm*

Use <UP> or <DOWN> to add or subtract an offset to the IAQ signal. Can change from -200 to +200 ppm in 10 ppm increments.

<MENU> Press to advance to next menu item

*Relay
Test OFF*

Use <UP> or <DOWN> to toggle the relay on or off for testing.

<MENU> Press to advance to next menu item

*Relay SP
1000 ppm*

Use <UP> or <DOWN> to change the relay setpoint from 750-1500 ppm. Default is 1000. Resolution is 25 ppm.

<MENU> Press to advance to next menu item

*Relay Hy
100 ppm*

Can change the relay hysteresis to 20, 50, 100, or 200 ppm. Default is 100.

<MENU> Press to advance to next menu item

*Relay Dly
YES*

By default, the relay has a 1 minute minimum on time and a 1 minute minimum off time to prevent fast cycling. This feature can be disabled here.

<MENU> Press to advance to next menu item

*Relay Op
NO*

By default, the relay is normally open as its non-energized state. Use <UP> or <DOWN> to change to NC (normally closed).

<MENU> Exits the User menu and returns the normal operation. The LCD flashes "Menu Exits" for 3 seconds.

SPECIFICATIONS:

Sensing Technology	MEMS metal oxide semiconductor VOC sensor
Measurement Range	450-2000 ppm CO2 equivalent or 0-100% (menu selectable)
Drift Compensation	Automatic baseline correction
Power Supply	20-28 Vac/dc (non-isolated half-wave rectified)
Consumption	35 mA max @ 24 Vdc
Input Voltage Effect	Negligible over specified operating range
Protection Circuitry	Reverse voltage protected, over voltage protected
Operating Conditions	0-50°C (32-122°F), 5-95 %RH non-condensing
Linear Output Signal	0-5 / 0-10 Vdc (menu selectable) = 0-2000 ppm CO2 equivalent
Analog Stepped Output Signal ..	Three steps representing Good, Fair, and Poor air quality (each step is independently adjustable from 0-10 Vdc)
Output Drive Capability	10 KΩ minimum
Programming and Selection ...	Via internal push-buttons and LCD menu
Warm-up Time	5 minutes
LCD Resolution	1 ppm / 1%
LCD Size	35 mm W x 15 mm H (1.4" x 0.6") alpha-numeric 2 line x 8 characters
Wiring Connections	Screw terminal blocks, 14 to 22 AWG
Probe	152 mm L x 22.5 mm D (6" x 0.88")
Weight	290 gm (10.2 oz)
Relay Output	Form A contact (N.O.) 5 Amps @ 250 Vac, 5 Amps @ 30 Vdc for resistive load 2 Amps @ 250 Vac, 2 Amps @ 30 Vdc for inductive load (trip point and hysteresis set via menu)
Optional Temperature Sensor ..	Various thermistors and RTDs, 2-wire resistive output
Enclosure	Grey polycarbonate with gasket, UL94-V0 IP65 (NEMA 4X) F style includes thread adapter (1/2" NPT to M16) and cable gland fitting 116.5 W x 112.5 H x 53.7 D mm (4.585" x 4.43" x 2.115")
Country of Origin	Canada

DIMENSIONS

