

Gauge Pressure Transmitter WPRG Series

Installation Instructions

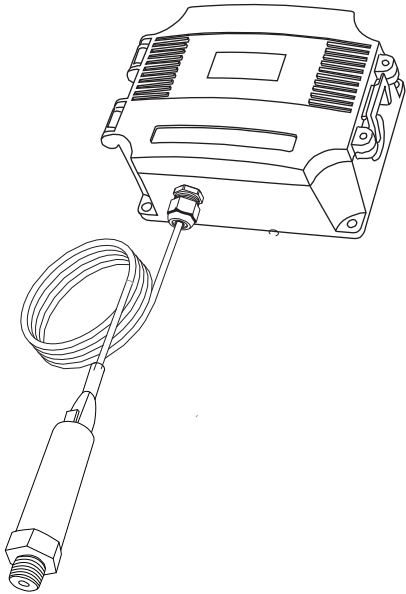

Introduction

The gage pressure transmitter is designed with a single remote sensor that enables it to accept high pressure in several ranges up to 500 PSI, 30 Bar or 3000 kPa. All models can handle overload pressure 2X the maximum full scale range and burst pressure is 5X the maximum full scale range.

Features include field selectable pressure ranges, output signal types, output reversal and slow-dampening for the most flexible applications. The output signal is factory calibrated and temperature compensated for the highest start-up accuracy.

WARNING : Ensure that the maximum individual port pressure does not exceed the highest pressure range of the unit. For example, the highest individual port pressure on a WPRD102 is 100 PSI. Exceeding this may damage the sensors and give erroneous readings. See Figure 9 for ratings.

Before Installation

Read these instructions carefully before installing and commissioning the DP transmitter. Failure to follow these instructions may result in product damage. Do not use in an explosive or hazardous environment, with combustible or flammable gases, as a safety or emergency stop device or in any other application where failure of the product could result in personal injury. Take electrostatic discharge precautions during installation and do not exceed the device ratings.

Mounting

The transmitter mounts on a vertical surface using the four mounting holes on the base of the unit. The remote sensor cable connection should be located on the bottom of the enclosure. The four mounting holes will facilitate a #10 size screw (not supplied). See **Figure 1**. Ensure there is enough space around the unit to make the electrical connections and that it is within an acceptable distance for the length of remote sensor cable. Avoid locations with severe vibrations or excessive moisture. The enclosure has a standard opening for a conduit connector or cable gland type fitting.

The enclosure has a hinged cover with latch. Open the cover by pulling slightly on the latch on the right side of the enclosure and at the same time pulling on the cover, as illustrated in **Figure 2**.

A 21 mm (0.8125") hole is provided for connection of either a 1/2" conduit connector or a cable gland style connector. Insert the conduit or cable gland connector through the hole and securely fasten using a locknut as shown in **Figure 3**.

Two security screws are provided which can be installed to help secure the cover once settings and wiring connections are complete. See **Figure 4**.

Figure 1

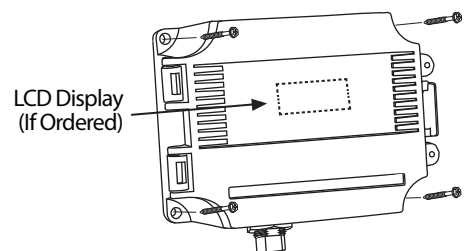

Figure 2

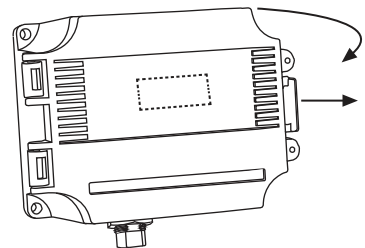

Figure 4

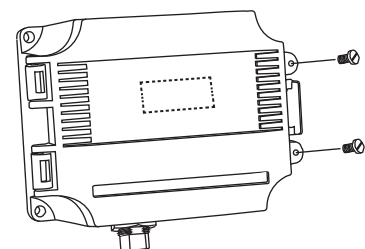
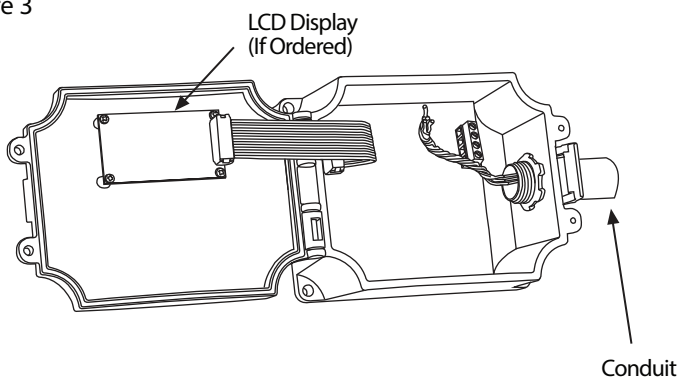

Figure 3



Plumbing

The S/S pressure sensor incorporates 1/4" NPT male threads for connection to the pipe being monitored.

Do not allow material to fall into the pressure sensor as contamination could damage the sensor. It is recommended to use teflon tape to prevent leaks.

Remove the pressure sensor from the remote cable by pressing on the release and pulling apart from the remote cable boot as shown in **Figure 6**.

Wrap the 1/4" NPT male sensor threads with teflon tape. Screw into the sensor port on the pipe being monitored until finger tight. Using an appropriate size wrench, tighten the sensor until snug as shown in **Figure 7**.

Reconnect the remote sensor cable by aligning the remote sensor cable boot and pushing firmly onto sensor. See **Figure 8**.

Configuration

As shown on the drawing in **Figure 9**, several DIP switches are used to select the output signal type, the input pressure range and features that include Backlight on/off, bidirectional operation, port swap, slow damping and analog reverse functions.

WARNING: The DP transmitter must NOT have power applied during set up or when making changes to the Output signal.

OUTPUT SELECTION: The DP transmitter comes with user-selectable outputs of 4-20 mA, 0-5 Vdc and 0-10 Vdc. **It is factory configured to operate in the CURRENT (4-20 mA output) mode**, but can be changed to VOLTAGE mode by sliding the output selection switch from the position marked CURRENT to the position marked VOLTAGE as shown in **Figure 10**.

In VOLTAGE mode the output scale may be changed to either 0-5 or 0-10 Vdc by moving the DIP switch to the 10V or 5V position as shown in **Figure 8**. **The factory default is 10V.**

If CURRENT mode was selected, DIP switch position in Figure 10 is not applicable.

RANGE SELECTION: Each model of the DP transmitter includes four pressure ranges to select from. The input pressure range is set by moving one of the 4 DIP switches to the on position as shown in **Figure 12**.

The factory default for every model is Range 1.

The model number is printed on a label showing the available ranges for that model is adhered to the inside of the enclosure.

FEATURES:

The factory default for all features is OFF except the Backlight if LCD is ordered. Backlight default is ON. See Figure 10.

BACKLIGHT ON: If the DP transmitter was ordered with the LCD option, this switch can be used to turn the backlight on/off. The backlight is enabled in the ON position but can be set to OFF to reduce power consumption.

Figure 5

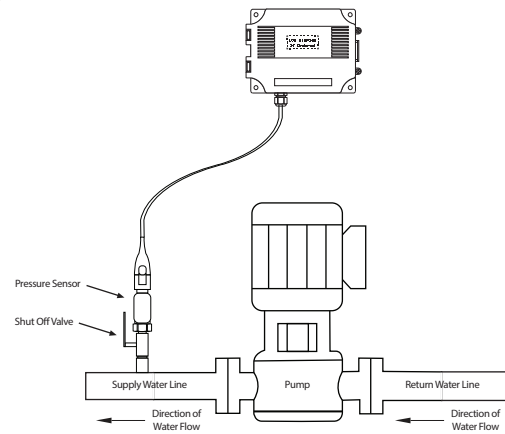

Figure 6

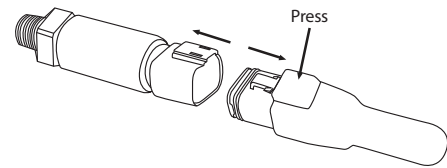

Figure 7

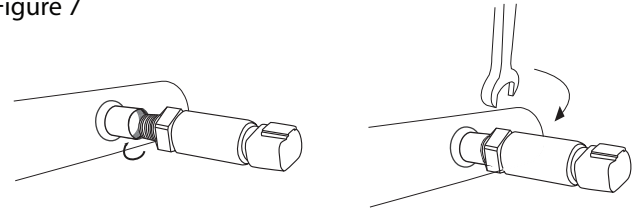

Figure 8

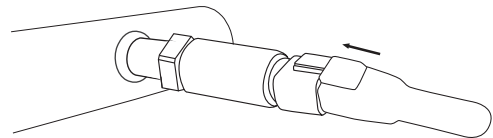

Figure 9

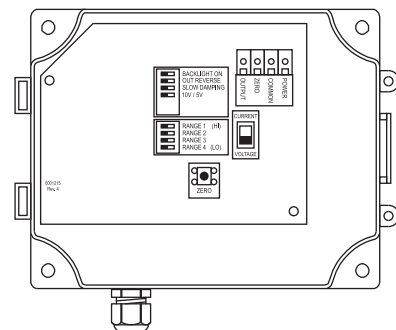

Figure 10

Output Type Selection



Factory default is CURRENT

Figure 11

Output Voltage Span Selection

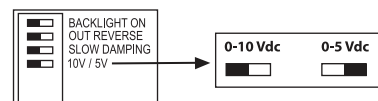

Configuration continued

OUTPUT REVERSE: This switch reverses the output signal polarity. In reverse mode the analog output is maximum when the pressure differential is zero and decreases as pressure increases.

SLOW DAMPING: This switch provides an 8-second averaging for surge dampening (normally it is 4-seconds).

To turn any of these features on slide the appropriate DIP switch to the ON position as shown in **Figure 13**.

Wiring

- Deactivate the 24 Vac/dc power supply until all connections are made to the device to prevent electrical shock or equipment damage.
- Use 14-22 AWG shielded wiring for all connections and do not locate the device wires in the same conduit with wiring used to supply inductive loads such as motors. Make all connections in accordance with national and local codes.
- Pull at least six inches of wire into the enclosure, then complete the wiring connection according to the wiring diagram for the applicable power supply and output signal type.
- Connect the plus DC or the AC voltage hot side to the POWER terminal. For voltage output or AC power, the supply Common is connected to the COMMON terminal. **DO NOT connect power to the OUTPUT terminal as the device will be damaged.**
- It has a half-wave power supply so the supply Common is the same as the signal Common. See **Figure 14**.
- The analog output is available on the OUTPUT terminal.
- Check the controller Analog Input to determine the proper connection before applying power.
- If using the Zero function, connect the Remote Zero Switch between the ZERO and COMMON terminals.

Figure 12

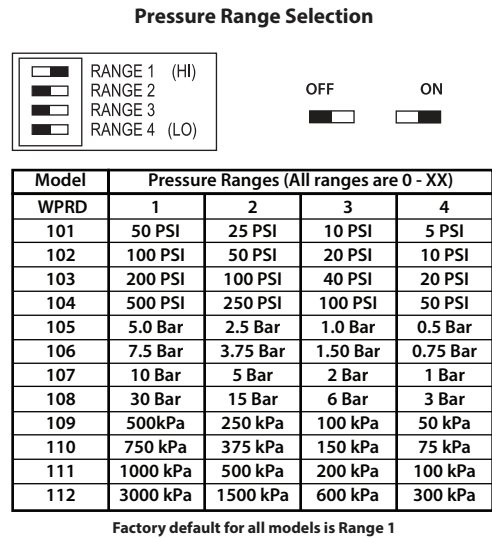

Figure 13

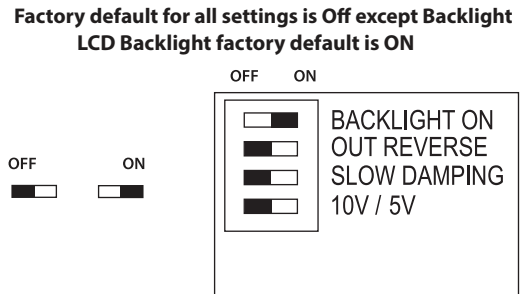
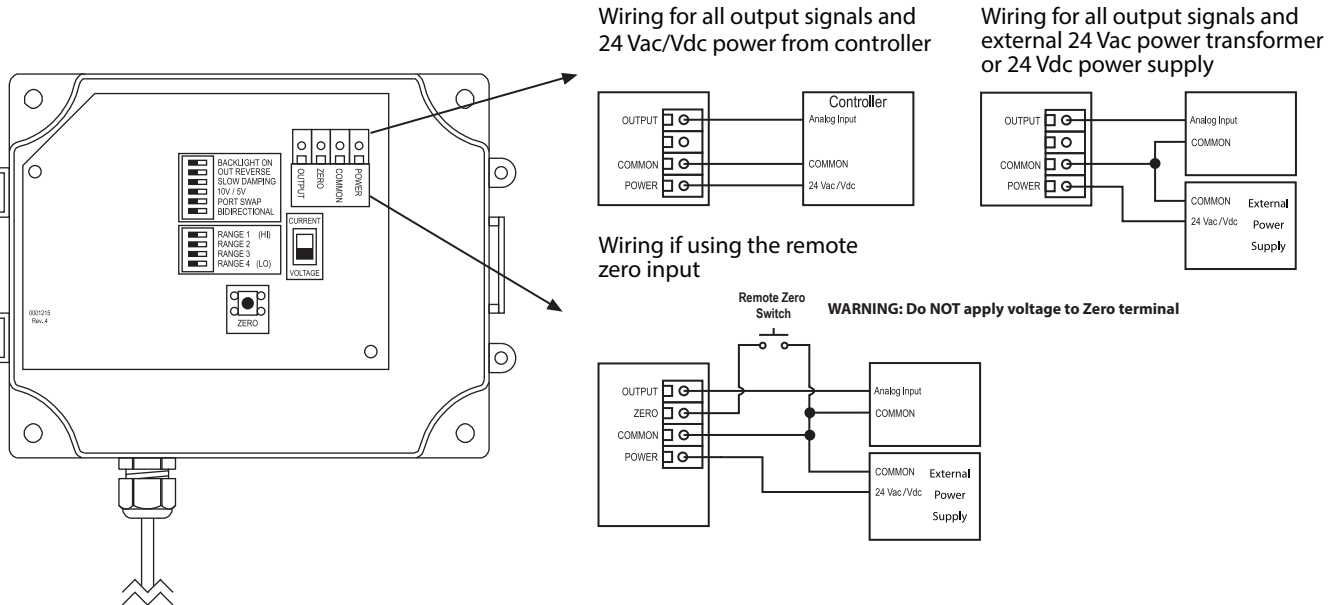

Figure 14



Operation:

For normal operation such as 0-100 PSI, the port is used to measure a positive pressure and 0 PSI = 4 mA and 100 PSI = 20 mA

Calibration:

With the port open to the ambient pressure, press and hold the auto-zero button or provide contact closure on the ZERO terminals for at least 3 seconds. See **Figure 15**. Release the button or terminals and the device will calculate and store the new zero point. To protect the unit from accidental zeroing this feature is enabled only when the detected pressure is less than 5% of the full range. It is not recommended that span calibration be performed in the field unless a high quality calibrator is available.

Specifications:

Media Compatibility	17-4 PH stainless steel
Pressure Ranges.....	4 switch selectable ranges per model - See Figure 12
Line Pressure	Max. line pressure is the highest of the selectable ranges on each model
Proof Pressure	Max. 2X highest range per model
Burst Pressure.....	Max. 5X highest range per model
Accuracy	± 1% F.S. of range selected with combined linearity, hysteresis, and repeatability
Pressure Cycles	>100 million
Surge Damping	Normal: 4 second averaging Slow: 8 second averaging, switch selectable
Sensor Operating Range	-40° to 85°C (-40° to 185°F)
Compensated Range.....	0° to 55°C (32° to 130°F)
Operating Environment	0° to 50°C (32° to 122°F), 10-90% RH condensing
Stability	±0.25% typical (1 year)
Zero Adjust.....	Push-button auto-zero and digital input
Power Supply.....	18 to 28 Vac/Vdc (non-isolated half-wave rectified)
Consumption	100 mA max @ 24 Vdc with LCD backlight, 35 mA with backlight disabled
Output Signal.....	3-wire transmitter; selectable 4-20mA active (sourcing), 0-5 or 0-10 Vdc
Pressure Connections.....	1/4" NPT male
Remote Cable.....	S = FT6 Plenum Rated A = Armoured Flexible S/S
Enclosure	ABS, UL94-5VB hinged lid with gasket, IP65 (Nema 4X)
Dimensions.....	145 X 100 X 64 mm (5.7" X 3.95" X 2.5")
Shock	100G, 11 mSec, 1/2 sine
Vibration	10G peak 20 to 2000 Hz
Wiring Connections	Screw terminal block (14 to 22 AWG)
Optional LCD Display	35 mm x 15 mm (1.4" w x 0.6" h) alpha-numeric 2 line x 8 character Resolution - 1 psi Backlight - Enable or disable via jumper

Dimensions:

