

REMOTE SPOT WATER DETECTOR

Installation Instructions

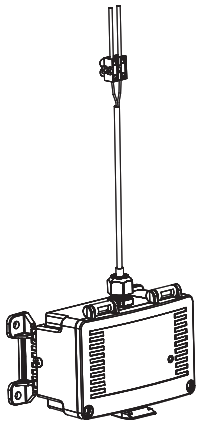

INTRODUCTION

The remote spot water detector is used to detect the presence of water or conductive liquids. It is available with either one or two relay outputs and is designed to signal alarms if one or more of three conditions are met: water is detected, power is lost to the unit, or if there is an internal failure.

The remote spot water detector is housed in an IP65 rated enclosure with remote sensing probes and cable that is available in various lengths. It features height adjustable mounting legs that include 5 preset mounting heights. An LED provides visual status indication.

BEFORE INSTALLATION

- Read these instructions carefully before installing and commissioning the water detector. Failure to follow these instructions may result in product damage.
- Do not use in an explosive or hazardous environment, with combustible or flammable gases, as a safety or emergency stop device or in any other application where failure of the product could result in personal injury.
- **Take electrostatic discharge precautions during installation and do not exceed the device ratings.**

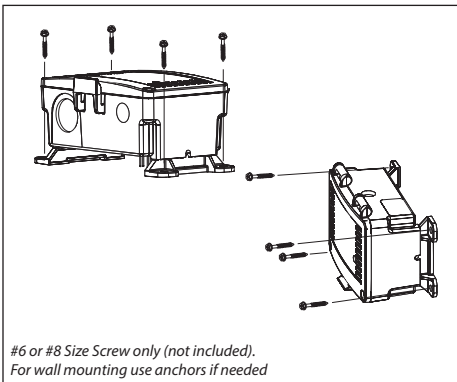

1 Secure by applying a silicone adhesive to the mounting feet and placing the sensor in the area to be protected. For more permanent installations, fasten the sensor using the holes provided in the mounting feet.

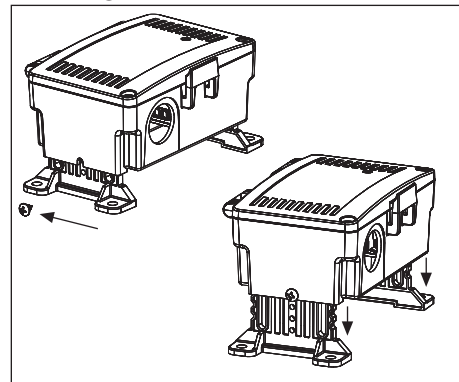

2 The legs have five pre-set heights set by the holes in the leg. To adjust leg height, remove the screws. Pull/push the legs to the height desired, and re-insert screws and tighten.

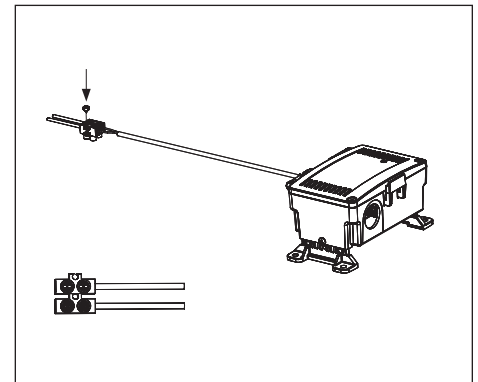

3 Route the cable to desired location. Mount the terminal block using a screw or adhesive. Make sure sensing probes do not contact any surface.

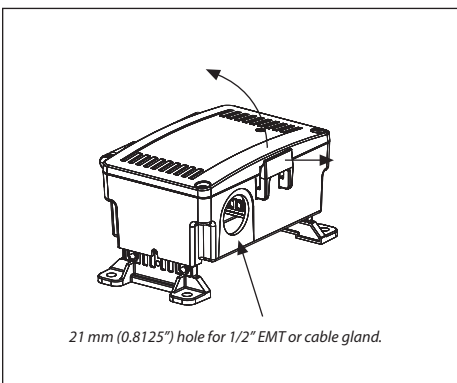

4 Open the cover by pulling slightly on the latch on the enclosure and at the same time pulling up on the cover.

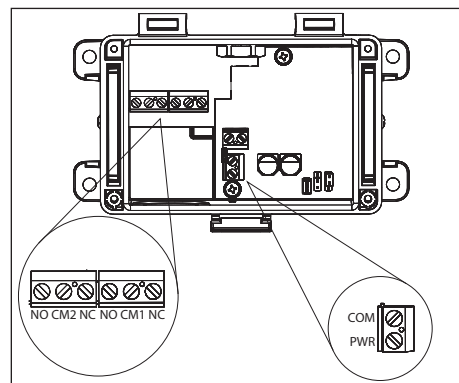

5 Make all connections in accordance with national and local codes. Use 14-22 AWG shielded wire and do not locate the device wires in the same conduit with wiring used to supply inductive loads such as motors. The device is reverse voltage protected and will not operate if connected backwards.

NOTE: All jumpers are factory set. Do not change jumper position. Changing jumper position will cause device to be in constant alarm state.

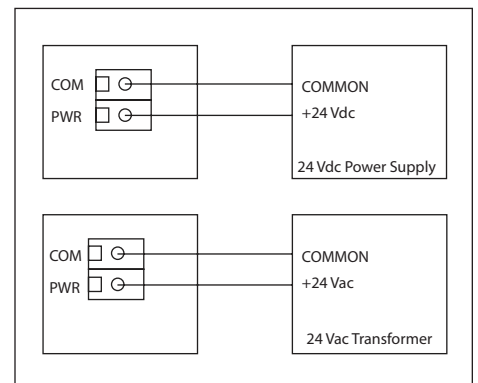

6 To prevent electrical shock or equipment damage make all connections before applying power. Connect 24 Vac/Vdc to PWR & COM terminals.

NOTE: Use caution when wiring multiple devices or when grounding the secondary of a transformer to ensure that the circuit ground point is the same on all devices and the controller.

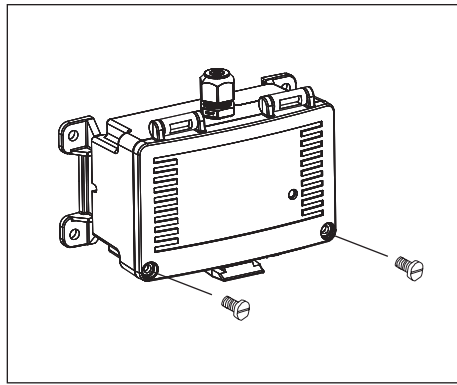
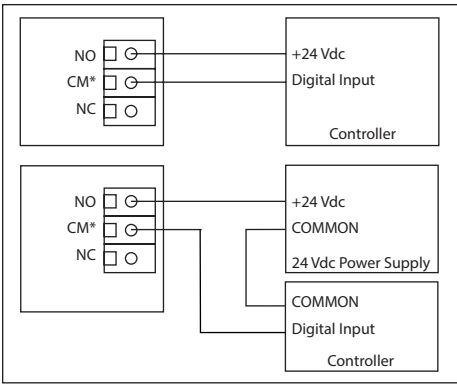

7 Do not exceed the device contact ratings. The relays are Form C type with both a normally open (NO) and a normally closed (NC) contact. Relay terminals are designated NO, CM* and NC.

8 Use the provided security screws to secure the cover.

NOTE: Each relay output is independent and isolated from the other and the relays COMs are not connected to the device COM.

OPERATION

When the sensor is powered on the controller will monitor the liquid detection channels. If a conductive liquid comes in contact with the sensor probes the controller will trigger the relay(s) to indicate liquid is present.

The relays are fail-safe, meaning when power is applied to device the relay is powered. If power is lost to device the relay will de-energize signaling a fault to the system.

1 Relay Model

Relay Activates on water detection.

2 Relay Model

Relay 1 and Relay 2 Activate on water detection.

LED: Green = No water

Red = Water Detection

SPECIFICATIONS

POWER SUPPLY	12 - 27 Vac/dc
SUPPLY CURRENT	125 mA max @ 24 Vac
ALARM OUTPUT	1 or 2 Form C relay(s), NO/NC, rated 2 Amps @ 30 VAC/VDC, 0.5 Amps @ 120 VAC (resistive load)
VISUAL INDICATION	Bi-color LED - Green, Red
OPERATING TEMPERATURE	0 to 50°C (32 to 122°F)
ENCLOSURE	ABS with hinged and gasket cover, IP65 (NEMA 4X)
DIMENSIONS	133.2mm L x 86.7mm W x 60.3-85.7mm H (5.2" x 3.4" x 2.4" - 3.4")
CABLE TYPE	FT-6 Plenum rated
APPROVALS	CE, RoHS
COUNTRY OF ORIGIN	Canada

DIMENSIONS

