

Remote Probe Strap-on Temperature Sensor

Installation Instructions

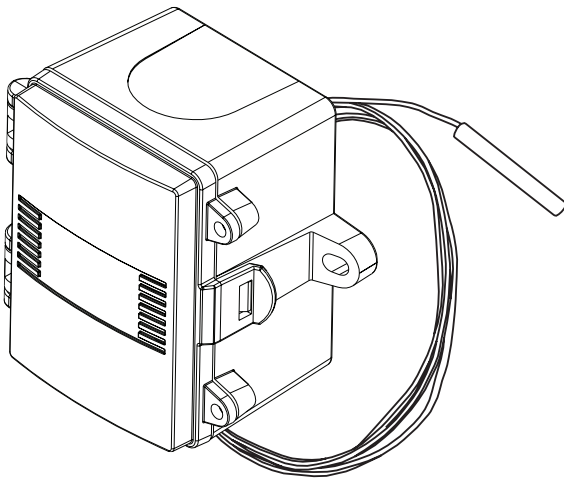

INTRODUCTION

The single point remote probe strap-on temperature sensor utilizes a precision sensor encapsulated in a 6 mm (0.236") OD, 304 stainless steel probe and is available in various lengths. Standard wire length is 1.5 m (5'). All probes are constructed to provide excellent heat transfer, fast response and are potted to resist moisture penetration. A compact ABS enclosure with a hinged and gasketed cover is provided for ease of installation.

BEFORE INSTALLATION

Read these instructions carefully before installing and commissioning the temperature sensor. Failure to follow these instructions may result in product damage. Do not use in an explosive or hazardous environment, with combustible or flammable gases, as a safety or emergency stop device or in any other application where failure of the product could result in personal injury. **Do not exceed the device ratings.**

MOUNTING

The strap-on sensor installs directly onto any pipe where an immersion sensor with thermowell can't be installed. Once a suitable spot is selected, remove a small section of insulation if present and set aside. It is recommended that thermal compound be used to improve heat transfer. Spread a liberal amount on the pipe. Lay probe in thermal compound and secure sensor to pipe using a worm gear clamp (not included). For added protection it is recommended to wrap probe cable around pipe 1 to 2 times as shown in Figure 1. Re-install insulation if present, allowing sensor cable to protrude.

Mount the enclosure on a flat surface in close proximity to the area where the probe inserted on the pipe. Secure the enclosure with two #10 x 25 mm (1") self tapping screws (not provided). As shown in Figure 2.

The enclosure has a hinged cover with a latch. Open the cover by pulling slightly on the latch on the right side of the enclosure. At the same time pulling on the cover, as shown in Figure 3.

A 1/2" NPT threaded connection hole is provided in the bottom of the enclosure. Screw the EMT connector or cable gland connector in until tight. See Figure 4. It is recommended that weatherproof conduit or cable gland fittings be used. The E style enclosure includes 1/2" NPT to M16 thread adapter and cable gland fitting.

Make wiring connections as per the "Wiring" illustrations on Page 2.

Swing door closed until securely latched. For added security, 2 screws are provided that may be installed in the integrated screw tabs. See Figure 5.

Figure 1

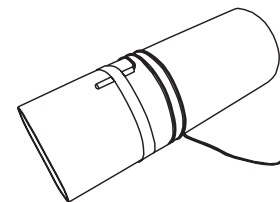

Figure 2

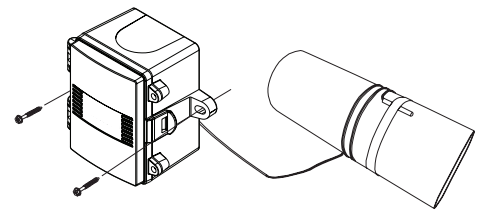

Figure 3

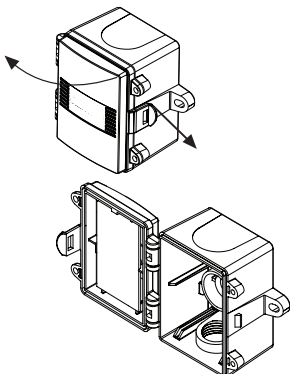

Figure 4

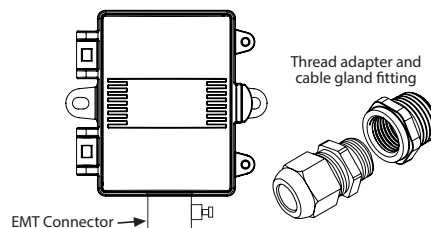
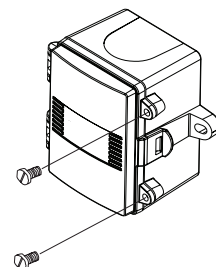
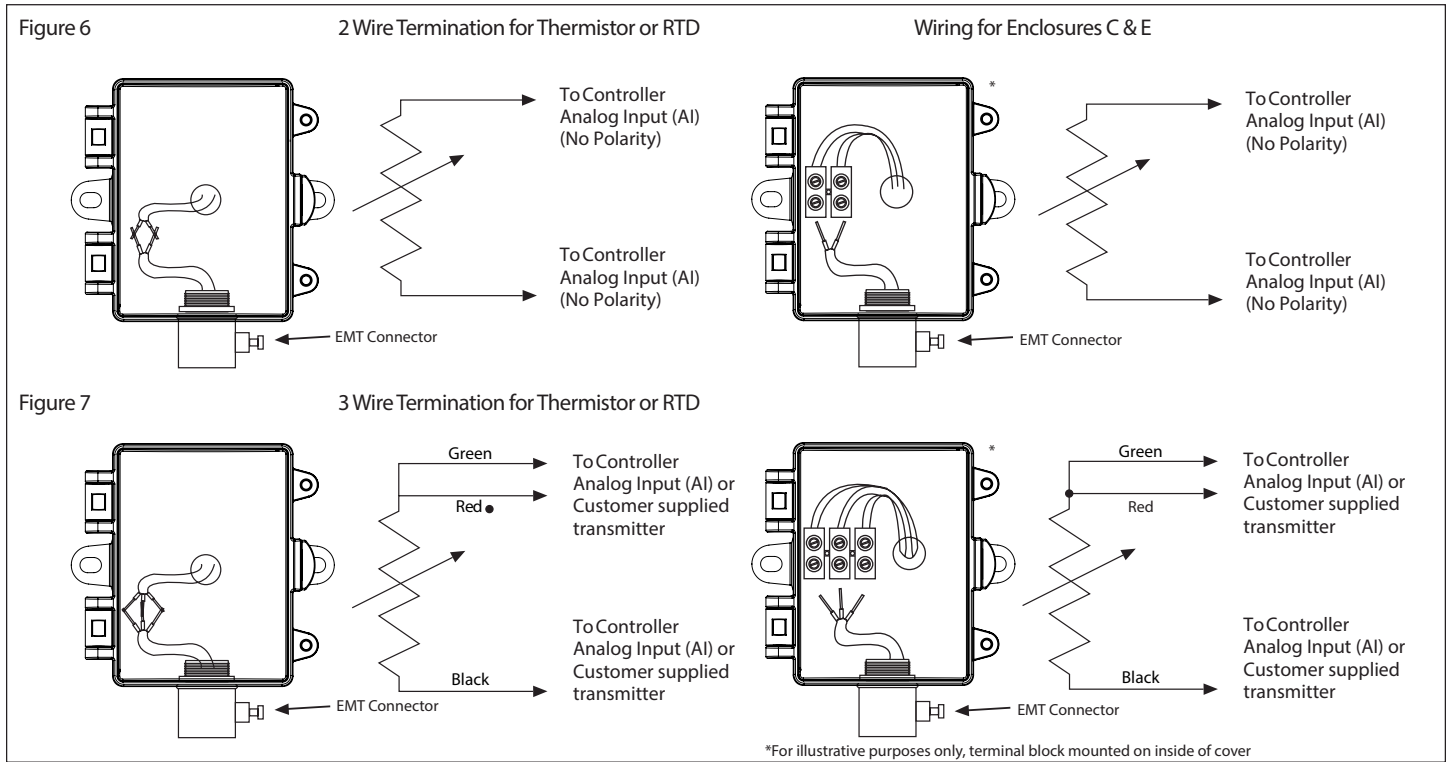

Figure 5



WIRING

- Use 18-24 AWG shielded wiring for all connections. Do not locate the device wires in the same conduit with wiring used to supply inductive loads such as motors. Make all connections in accordance with national and local codes.
- Pull at least six inches of wire into the enclosure, then complete the wiring connection according to the wiring diagrams below.
- All thermistors and most RTD's are a 2 wire hook up and are not polarity sensitive. See Figure 6.
- For RTD's that are 3 wire connection see Figure 7.



TYPICAL WIRE RESISTANCE VALUES

When using low resistance sensors, long wire runs can add significant error to the readings. Use the following chart to determine errors due to wire resistance or consider using a 1000 ohm sensor or a transmitter for better accuracy. Locate the type of wire being used. Multiply the total length of the wire (distance from the controller to the sensor and back) by the number found in the chart below for total resistance.

GAUGE WIRE TYPE	18 AWG	22 AWG	24 AWG
STRANDED (OHMS/FOOT)	5.85 mΩ	14.75 mΩ	23.29 mΩ
SOLID (OHMS/FOOT)	6.4 mΩ	15.85 mΩ	25.72 mΩ

DIMENSION

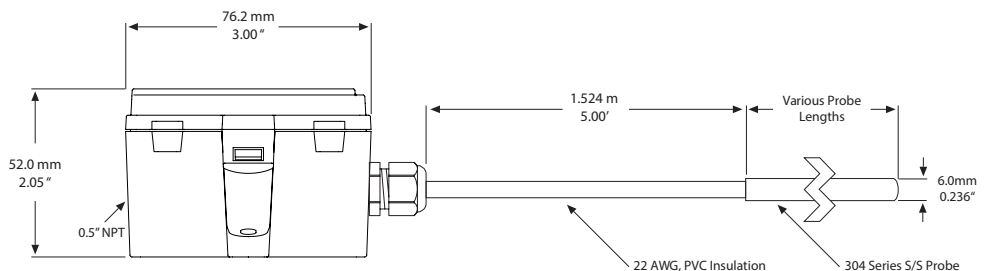
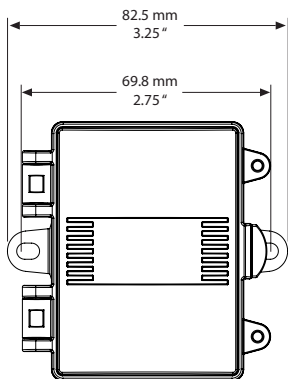

SPECIFICATIONS:

- Sensor Type:.....Various thermistors or RTD
- Sensor Accuracy:.....**Thermistors:** $\pm 0.2^\circ\text{C}$ ($\pm 0.36^\circ\text{F}$) @ 25°C (77°F)
Platinum RTD's: $\pm 0.3^\circ\text{C}$ ($\pm 0.54^\circ\text{F}$) @ 0°C (32°F)
Nickel RTD's: $\pm 0.4^\circ\text{C}$ ($\pm 0.72^\circ\text{F}$) @ 0°C (32°F)
- Probe Sensing Range:.....-40 to 100°C (-40 to 212°F)
- Ambient Operating Range:.....0 to 50°C (32 to 122°F)
- Wire Material:.....PVC insulated, parallel bonded, 22 AWG
- Wire Length:.....1.524 m (5')
- Probe Material:.....304 Series Stainless Steel
- Probe Diameter:.....6 mm (0.236")
- Enclosure:.....ABS - UL94-V0, IP65 (NEMA4X)
C - includes terminal block
E - includes thread adapter (1/2" NPT to M16), cable gland fitting, and terminal block
- Termination:.....A - pigtail, 2 or 3 wire
C & E - terminal block, 2 or 3 wire
- Country of Origin:.....Canada

PRINTED IN CANADA