

# Flexible Copper Duct Average High Limit Thermostat

## Installation Instructions

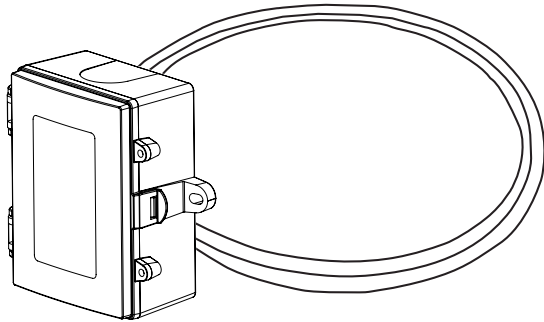

### INTRODUCTION

The flexible copper duct average temperature thermostat incorporates numerous precision thermistor temperature sensors and provides a Form C relay output (NO/NC) with an adjustable setpoint. The sensor is encapsulated in a 7.94 mm (0.3125") OD, soft copper tube and is available in various lengths. All probes provide excellent heat transfer, fast response and resist moisture penetration.

### BEFORE INSTALLATION

Read these instructions carefully before installing and commissioning the temperature sensor. Failure to follow these instructions may result in product damage. Do not use in an explosive or hazardous environment, with combustible or flammable gases, as a safety or emergency stop device or in any other application where failure of the product could result in personal injury. **Do not exceed the device ratings.**

### MOUNTING

The sensor installs directly into any air duct with several lengths available for a wide range of duct widths/diameters. Select a suitable installation area in the middle of the duct wall. To achieve the best reading, do not place in an area where air stratification may be present. Mount the sensor at least 1.5 m (5') in either direction from elbows, dampers, filters or other duct restrictions. Avoid areas where the sensor is exposed to vibrations or rapid temperature changes.

Once a suitable spot is selected, drill a 9.5 - 12 mm (3/8" - 1/2") hole. Uncoil the copper probe and slide into the drilled hole until the enclosure is flush against the duct. The airflow direction is not important. Secure the enclosure to the duct with #10 x 25 mm (1") self tapping screws (not provided). Tighten screws until the enclosure is tight against the duct and that there is no movement of the enclosure as shown in Figure 1.

A foam gasket is provided on the back of the enclosure that provides a tight seal against any air leaks.

The probe can easily be shaped to fit any duct size but observe a minimum bend radius of 4" to prevent damage to the wire or sensors. Criss-cross the duct multiple times so that the probe covers a large section of the duct. The probe needs to be fastened onto hangers using tube clamps or wire ties. See Figure 2.

The enclosure has a hinged cover with a latch. Open the cover by pulling slightly on the latch on the right side of the enclosure. At the same time pulling on the cover, as illustrated in Figure 3.

A 1/2" NPT threaded connection hole is provided in the bottom of the enclosure. Screw the EMT connector or cable gland connector in until tight. See Figure 4. It is recommended that weatherproof conduit or cable gland fittings be used. The F style enclosure includes a 1/2" NPT to M16 thread adapter and cable gland fitting.

Make wiring connections as per the "Wiring" illustrations on Page 2.

Swing door closed until securely latched. For added security, 2 screws are provided that may be installed in the integrated screw tabs. See Figure 5.

Figure 1

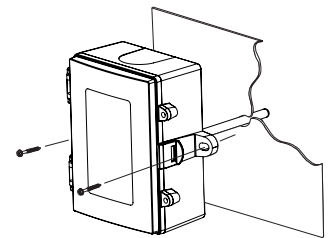

Figure 2

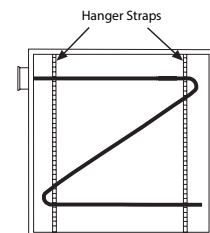

Figure 3

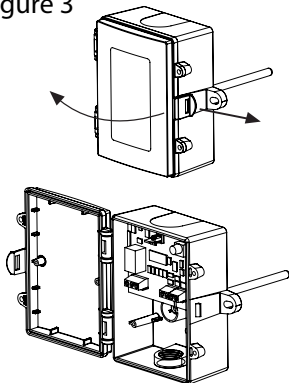

Figure 4

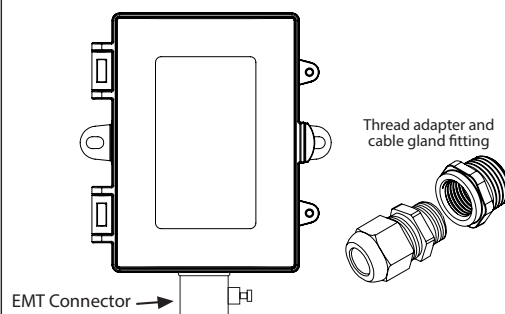
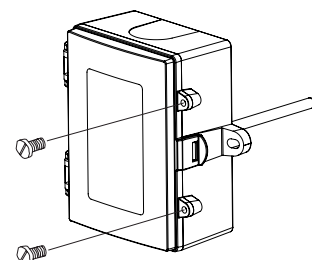
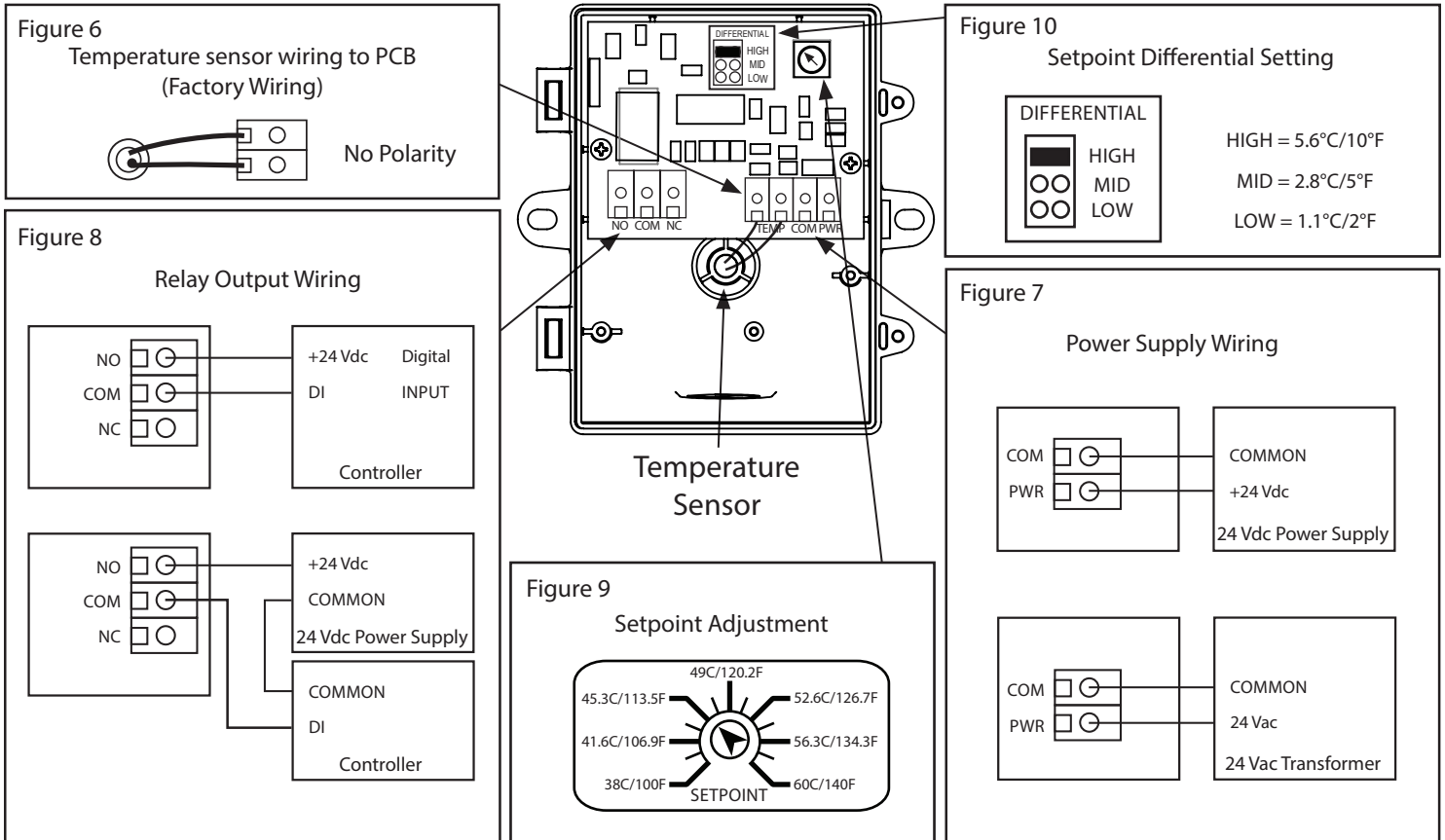

Figure 5



# WIRING

- Deactivate the 24 Vac/dc power supply until all connections are made to the device to prevent electrical shock or equipment damage.
- Use 14-22 AWG shielded wiring for all connections and do not locate the device wires in the same conduit with wiring used to supply inductive loads such as motors. Make all connections in accordance with national and local codes.
- The temperature thermostat comes with the temperature sensor pre-wired to the PCB. If removal is required for installation then it may be re-wired as shown in Figure 6.
- Pull at least six inches of control wire into the enclosure, then complete the wiring connection according to the wire diagram for the applicable power supply as shown in Figure 7.
- Connect the DC positive or the AC voltage hot side to the PWR terminal. The supply common is connected to the COM terminal. See Figure 7.
- The relay has both Normally Open (NO) and Normally Closed (NC) contacts available. The relay output is available on the NO/COM/NC terminal. Make connections before applying power as shown in Figure 8.
- The setpoint differential has 3 jumper selectable settings (Low/Mid/High). Set jumper to desired differential as shown in Figure 10.
- To set the switching setpoint, turn the setpoint potentiometer to the desired temperature setting as shown in Figure 9.
- Once all connections settings are made and checked, power can be applied.



## SPECIFICATIONS:

- Power Supply:.....12 to 28 Vac/dc
- Consumption:.....50 mA max
- Relay Contacts:.....SPDT, Form C contacts (N.O. and N.C.)  
5 Amps @ 30 Vac/250 Vac resistive  
1.5 Amps @ 30 Vdc/250 Vac inductive
- Relay Action:.....Activates on temperature rise
- Setpoint Operation:.....Single-turn knob-pot on PCB
- Adjustable Setpoint:.....38 to 60°C (100 to 140°F)
- Setpoint Temperature:.....Low/Mid/High jumper selectable  
Differential 1.1, 2.8, 5.6°C (2, 5, 10°F)
- Temperature Sensor:.....10K ohm curve matched precision thermistor
- Sensor Accuracy:.....±0.2°C, 0 to 70°C (±0.36°F, 32 to 158°F)
- Probe Sensing Range:.....-20 to 60°C (-4 to 140°F)
- Probe Material:.....Soft copper
- Probe Diameter:.....7.94 mm (0.3125")
- Probe Length: .....1800 mm, 3600 mm, 6100 mm, 7300 mm  
(6', 12', 20', 24')
- Wire Material:.....FT-6 Plenum-rated cable
- Operating Conditions:.....-10 to 50°C (14 to 122°F), 5 to 95% RH, non-condensing
- Storage Conditions:.....-30 to 70°C (-22 to 158°F), 5 to 95% RH, non-condensing
- Wiring Connections:.....Screw terminal block (14 to 22 AWG)
- Enclosure:.....Grey Polycarbonate UL94-V0, IP65 (NEMA 4X)  
Optional thread adapter (1/2" NPT to M16)  
and cable gland fitting
- Country of Origin:.....Canada

## DIMENSIONS

