

Strap-on Temperature Sensor Installation Instructions

ABS Enclosure



Other Enclosure Styles

Metal Enclosure



Weatherproof Enclosure



Strap-on Temperature Sensor

Designed for monitoring temperatures on pipes where an immersion sensor can not be used. It is available with various probe lengths and enclosures to fit any application

Temperature Transmitter Information

Mount the probe under any pipe insulation in direct contact with the pipe to measure the temperature of the pipe using metal pipe straps or cable ties. For best results, thermal compound should be used between the probe and pipe to improve heat transfer and the installation should be wrapped with insulation to reduce the effects of ambient air

Specifications

Standard Length	2", 4", 6", 8", 12", 18"
Operating Temperature Range	-20 to 105 °C (-4 to 221 °F)
Cable Type	PVC insulated, parallel bonded
Wiring Connections	Pig Tail (2 or 3 wire)
Enclosures	ABS, Metal or Weatherproof
Sensor Types	100 Ω, 1K PT, 1K Nickel RTD's, 1801 K, 3K, 10K (type 2 & 3) 20K & 100K Thermistors

Typical Wire Resistance Values

When using low resistance sensors (i.e. 100 ohm RTD), long wire runs can add significant error to the readings. Use the following chart to determine errors due to wire resistance or consider using a 1000 ohm sensor or a transmitter for better accuracy. Locate the type of wire being used. Multiply the total length of the wire (distance from the controller to the sensor and back) by the number found in the following chart for total resistance

GAUGE WIRE TYPE	18 AWG	22 AWG	24 AWG
STRANDED (OHMS/ FOOT)	5.85 mΩ	14.75 mΩ	23.29 mΩ
SOLID (OHMS/FOOT)	6.4 mΩ	15.85 mΩ	25.72 mΩ

Wiring & Color codes

All two-wire sensors are polarity insensitive. The three-wire sensors have the following color code:

<u>Connection</u>	<u>Strap-on Wire Color</u>
EXCitation	RED
SENse	GREEN
NEGative	BLACK

To connect a three-wire sensor as a two-wire, tie the EXCitation and SENSE lines together.

Dual sensor probes will have one sensor on the RED and BLACK wires and the second sensor on the GREEN and WHITE wires.

Temperature Transmitter

Installation Instructions

Specifications

Power Supply	15-35 Vdc or 12-26 Vac (no LCD) 22-35 Vdc or 18-26 Vac (with LCD)	Output Signal	4-20 mA or 0-5 Vdc or 0-10 Vdc
Accuracy	± 0.1% FSO	Output Drive	>550 ohms (>325 ohms with LCD) 5K ohm min for voltage outputs
Operating Range . . .	0-70 °C (32-158 °F), 5-95 %RH -40-85 °C (-40-185 °F) for OSA	Wire Connections . . .	Screw terminal block (14-22 AWG)
		Standard Sensors . . .	100 ohm and 1000 ohm RTD

Wiring

Use shielded twisted pair wiring of at least 22 AWG for all connections and do not run the signal or power wires in the same conduit with wiring used to supply inductive loads such as motors. Disconnect the power supply before making any connections to prevent electrical shock or equipment damage. Make all connections in accordance with national and local electrical codes.

The sensor comes in either a 2-wire or 3-wire configuration. The 2-wire configuration is not polarity sensitive and can be connected to the NEG and EXC terminals. The 3-wire configuration will have RED-GREEN-BLACK wires or two like colored wires and one different colored wire. The BLACK or different colored wire connects to the NEG terminal. The RED/GREEN or like colored wires connect to the SEN and EXC terminals. It does not matter which color goes in which terminal.

The transmitter is available with either 4-20 mA, 0-5 Vdc or 0-10 Vdc output signals. Follow the example wiring diagrams to determine the correct wiring for the product. All models have the same terminal functions. For 4-20 mA loop powered operation, only PWR and OUT are required. The COM terminal is only used for voltage output types or for AC power.

Ensure the controller Analog Input (AI) matches the transmitter output signal type before power is applied. The device is reverse voltage protected and will not operate if connected backwards. The voltage output signal has a minimum load that it is able to drive and the current signal has a maximum load. Follow the ratings in the Specification section or inaccurate readings may result.

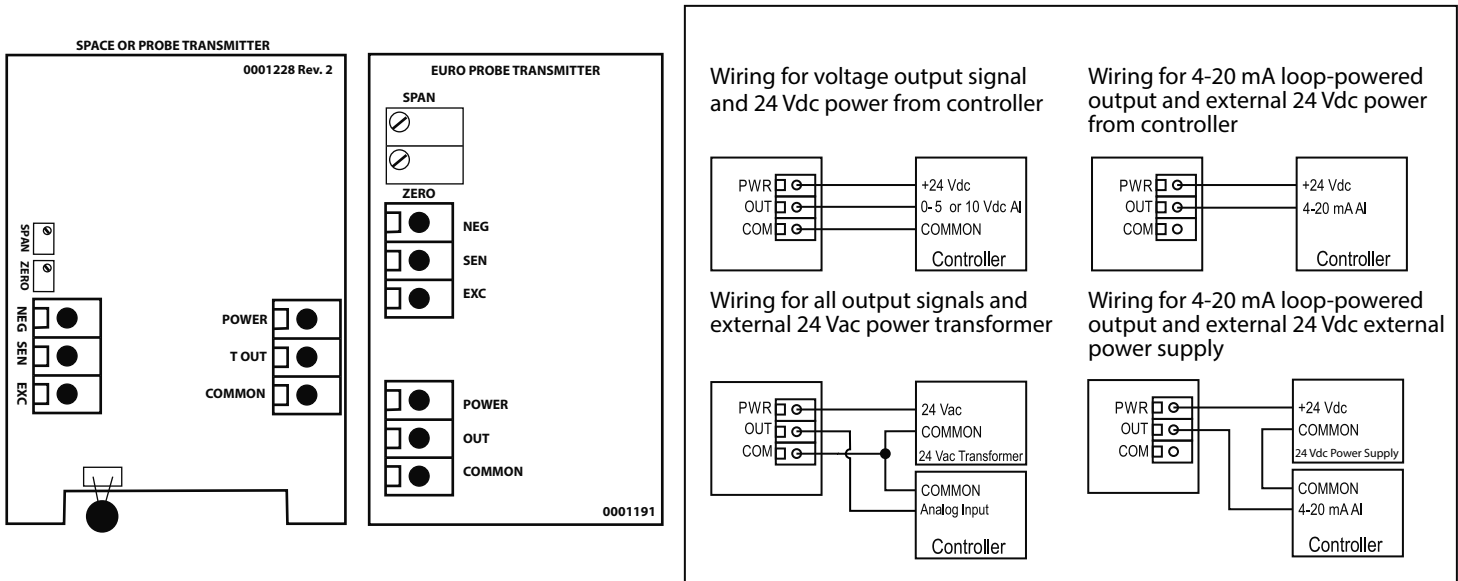

Operation

The product should be allowed to warm-up for several minutes before attempting to verify accuracy. Allow the transmitter to operate for 20 minutes before any calibration is performed.

The calibrated range of the transmitter is written on the board. Operation can be verified by measuring the output signal. For voltage output models, measure the voltage between the OUT and COM terminals. The voltmeter should read between 0-5 or 0-10 Vdc depending on the model. For current output models, insert a mA meter in series with the OUT terminal and it should read between 4 and 20 mA.

Calibration

The unit can be calibrated in the field using precision resistance values equal to the zero and span of the temperature range. Simply replace the attached probe with the resistor, then adjust the ZERO and SPAN pots accordingly to obtain the correct output signal. Repeat the adjustments until both values are correct. For units with 3-wire sensors jumper the SEN and EXC terminals with a wire.

The recommended temperature range for standard probe sensors is -25°C to 105°C (-13°F to 221°F) and Extended Temperature Probes are recommended for applications outside these temperatures. Extended Temperature Probes are available using both 100 Ohm and 1000 Ohm Platinum RTD's in thin-film types as applicable to operate between -70°C and 400°C (-94°F and 752°F), and using the 100 Ohm Platinum wire-wound ceramic RTD for applications between -125°C and 600°C (-193°F and 1112°F).

All Extended Temperature Probes consist of a stainless steel probe which is potted and back-filled, the requested sensor type, and wire rated for the required application. Metal boxes are required for use with Duct and Immersion type probes while Strap-on probes are usually supplied with ABS boxes. In the case where a transmitter board is included (TE5xx series) with an immersion sensor, the probe **MUST** be installed in the metal enclosure that does not contain the transmitter board. This is to prevent overheating of the board from heat transferal through the probe and fitting.

All Extended Temperature Probes are manufactured as 3-wire devices. The three wires are used for EXCITATION, SENSE and COMMON. The EXCITATION and SENSE wires are electrically connected together at the sensor and use the same colored wire (usually either red or black) while the COMMON wire is connected to the other side of the sensor and is a different colored wire (usually either white or yellow). This can be confirmed by measuring the resistance between the wires. The EXCITATION and SENSE wires will measure at about 0 ohms. Measuring between either the EXCITATION and COMMON or SENSE and COMMON will read the sensor resistance.

For 2-wire operation connect the EXCITATION and SENSE wires together or simply cut either one of these two wires and leave it unused.