

Strap-on Assembly Temperature Sensor

Installation Instructions

ABS Enclosure



Other Enclosure Styles

Metal Enclosure



Round ABS Enclosure



Strap-on Temperature Sensor

Designed for monitoring temperatures on pipes where an immersion sensor can not be used. It comes with a 10" quick-open worm drive stainless steel strap for fast and easy installation.

Installation

Mount the unit's copper plate so that it is in direct contact with the pipe to measure the temperature of the pipe using the worm drive strap. For best results, thermal compound should be used between the plate and pipe to improve heat transfer.

Specifications

Operating	-20 to 105 °C (-4 to 221 °F)
Cable Type	PVC insulated, parallel bonded
Wiring Connections	Pig Tail (2 or 3 wire)
Enclosures	ABS, Metal or Round ABS
Sensor Types	100 Ω, 1K PT, 1K Nickel RTD's, 1801 K, 3K, 10K (type 2 & 3) 20K & 100K Thermistors

Typical Wire Resistance Values

When using low resistance sensors (i.e. 100 ohm RTD), long wire runs can add significant error to the readings. Use the following chart to determine errors due to wire resistance or consider using a 1000 ohm sensor or a transmitter for better accuracy. Locate the type of wire being used. Multiply the total length of the wire (distance from the controller to the sensor and back) by the number found in the following chart for total resistance

GAUGE WIRE TYPE	18 AWG	22 AWG	24 AWG
STRANDED (OHMS/ FOOT)	5.85 mΩ	14.75 mΩ	23.29 mΩ
SOLID (OHMS/FOOT)	6.4 mΩ	15.85 mΩ	25.72 mΩ

Wiring & Color codes

All two-wire sensors are polarity insensitive. The three-wire sensors have the following color code:

<u>Connection</u>	<u>Strap-on Wire Color</u>
EXCitation	RED
SENse	GREEN
NEGative	BLACK

To connect a three-wire sensor as a two-wire, tie the EXCitation and SENSE lines together.

Dual sensor units will have one sensor on the RED and BLACK wires and the second sensor on the GREEN and WHITE wires.

Specifications

Power Supply 15-35 Vdc or 12-26 Vac (no LCD)
 22-35 Vdc or 18-26 Vac (with LCD)
 Accuracy $\pm 0.1\%$ FSO
 Operating Range . . . 0-70 °C (32-158 °F), 5-95 %RH
 -40-85 °C (-40-185 °F) for OSA
 Output Signal 4-20 mA or 0-5 Vdc or 0-10 Vdc
 Output Drive >550 ohms (>325 ohms with LCD)
 5K ohm min for voltage outputs
 Wire Connections . . . Screw terminal block (14-22 AWG)
 Standard Sensors . . . 100 ohm and 1000 ohm RTD

Wiring

Use shielded twisted pair wiring of at least 22 AWG for all connections and do not run the signal or power wires in the same conduit with wiring used to supply inductive loads such as motors. Disconnect the power supply before making any connections to prevent electrical shock or equipment damage. Make all connections in accordance with national and local electrical codes.

The transmitter is available with either 4-20 mA, 0-5 Vdc or 0-10 Vdc output signals. Follow the example wiring diagrams to determine the correct wiring for the product. All models have the same terminal functions. For 4-20 mA loop powered operation, only **PWR** and **OUT** are required. The **COM** terminal is only used for voltage output types or for AC power.

Ensure the controller Analog Input (AI) matches the transmitter output signal type before power is applied. The device is reverse voltage protected and will not operate if connected backwards. The voltage output signal has a minimum load that it is able to drive and the current signal has a maximum load. Follow the ratings in the Specification section or inaccurate readings may result.

If the TE510 has a dual sensor probe, connect the RTD (Red/Black) leads to the **SENSOR** terminals. The second sensor is Green/White.

Operation

The product should be allowed to warm-up for several minutes before attempting to verify accuracy. Allow the transmitter to operate for 20 minutes before any calibration is performed.

Operation can be verified by measuring the output signal. For voltage output models, measure the voltage between the **OUT** and **COM** terminals. The voltmeter should read between 0-5 or 0-10 Vdc depending on the model. For current output models, insert a mA meter in series with the **OUT** terminal and it should read between 4 and 20 mA. If an LCD is installed, it should indicate the same value as the output.

Calibration

The unit can be calibrated in the field using precision resistance values equal to the zero and span of the temperature range. Simply replace the attached probe with the resistor, then adjust the **ZERO** and **SPAN** pots accordingly to obtain the correct output signal. Repeat the adjustments until both values are correct. Note the TE510 also has adjustments for the LCD which can be done at the same time. For units with 3-wire sensors, remember to jumper the **SEN** and **EXC** terminals with a wire.

Loop Powered Connection With Controller 24 Vdc Power

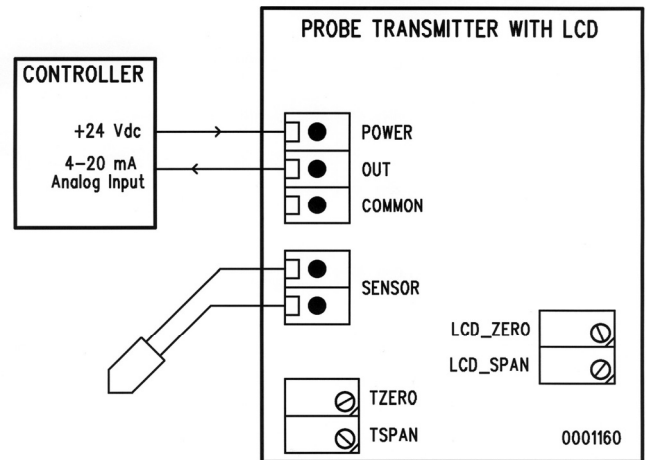

Voltage Connection With Controller 24 Vdc Power

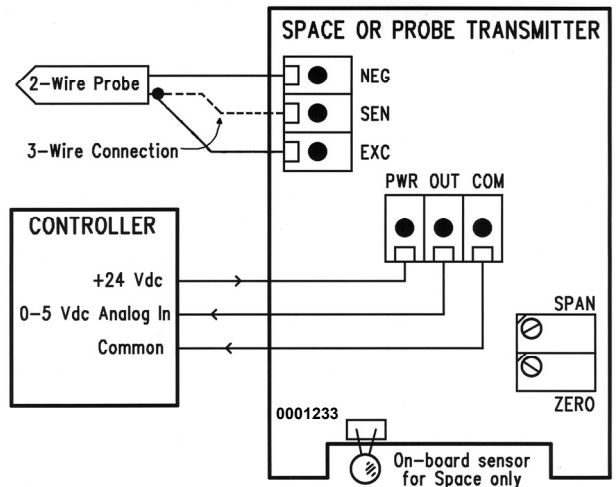

4-20 mA Connection With External 24 Vac Power

