

## ABS, Euro Enclosures



## Other Enclosure Styles

### Metal Enclosure



### Weatherproof Enclosure



## Rigid Duct Avg. Temperature Sensor

Designed for 4 point averaging temperature monitoring. It is available with various probe lengths and enclosures to fit any application.

## Specifications

Standard Lengths	18", 24", 36"
Operating Temperature Range	-20 to 105 °C (-4 to 221 °F)
Cable Type	PVC/Kynar insulated
Wiring Connections	Pig Tail (2 or 3 wire)
Enclosures	ABS, Euro, Metal or Weatherproof
Sensor Types	100 Ω, 1K PT, 1K Nickel RTD's, 1801 Ω, 3K, 10K (type 2 & 3), 20K & 100K Thermistors,

## Installation

The duct type probes are installed through a 1/4" hole in the side of the duct to monitor a single point temperature within the duct. Since the probes are tip sensitive, select a probe length that places the sensor well into the duct to avoid errors due to laminar flow. Install the probes in a straight section of duct away from heating, cooling or humidifier elements.

## Typical Wire Resistance Values

When using low resistance sensors (i.e. 100 ohm RTD), long wire runs can add significant error to the readings. Use the following chart to determine errors due to wire resistance or consider using a 1000 ohm sensor or a transmitter for better accuracy. Locate the type of wire being used. Multiply the total length of the wire (distance from the controller to the sensor and back) by the number found in the following chart for total resistance.

GAUGE WIRE TYPE	18 AWG	22 AWG	24 AWG
STRANDED (OHMS/FOOT)	5.85 mΩ	14.75 mΩ	23.29 mΩ
SOLID (OHMS/FOOT)	6.4 mΩ	15.85 mΩ	25.72 mΩ

## Wiring & Color codes

All two-wire sensors are polarity insensitive. The three-wire sensors have the following color code:

Connection	Wire Color
EXCitation	YELLOW
SENse	YELLOW
NEGative	BLACK

To connect a three-wire sensor as a two-wire, tie the EXCitation and SENse lines together. All connections should be made using either butt-splices or soldering. The use of wire nuts is not recommended.

# Temperature Transmitter

## Installation Instructions

### Specifications

Power Supply . . . . .	15-35 Vdc or 12-26 Vac (no LCD) 22-35 Vdc or 18-26 Vac (with LCD)	Output Signal . . . . .	4-20 mA or 0-5 Vdc or 0-10 Vdc
Accuracy . . . . .	± 0.1% FSO	Output Drive . . . . .	>550 ohms (>325 ohms with LCD) 5K ohm min for voltage outputs
Operating Range . . .	0-70 °C (32-158 °F), 5-95 %RH -40-85 °C (-40-185 °F) for OSA	Wire Connections . . .	Screw terminal block (14-22 AWG)
		Standard Sensors . . .	100 ohm and 1000 ohm RTD

### Wiring

Use shielded twisted pair wiring of at least 22 AWG for all connections and do not run the signal or power wires in the same conduit with wiring used to supply inductive loads such as motors. Disconnect the power supply before making any connections to prevent electrical shock or equipment damage. Make all connections in accordance with national and local electrical codes.

The sensor comes in either a 2-wire or 3-wire configuration. The 2-wire configuration is not polarity sensitive and can be connected to the NEG and EXC terminals. The 3-wire configuration will have RED-GREEN-BLACK wires or two like colored wires and one different colored wire. The BLACK or different colored wire connects to the NEG terminal. The RED/GREEN or like colored wires connect to the SEN and EXC terminals. It does not matter which color goes in which terminal.

The transmitter is available with either 4-20 mA, 0-5 Vdc or 0-10 Vdc output signals. Follow the example wiring diagrams to determine the correct wiring for the product. All models have the same terminal functions. For 4-20 mA loop powered operation, only PWR and OUT are required. The COM terminal is only used for voltage output types or for AC power.

Ensure the controller Analog Input (AI) matches the transmitter output signal type before power is applied. The device is reverse voltage protected and will not operate if connected backwards. The voltage output signal has a minimum load that it is able to drive and the current signal has a maximum load. Follow the ratings in the Specification section or inaccurate readings may result.

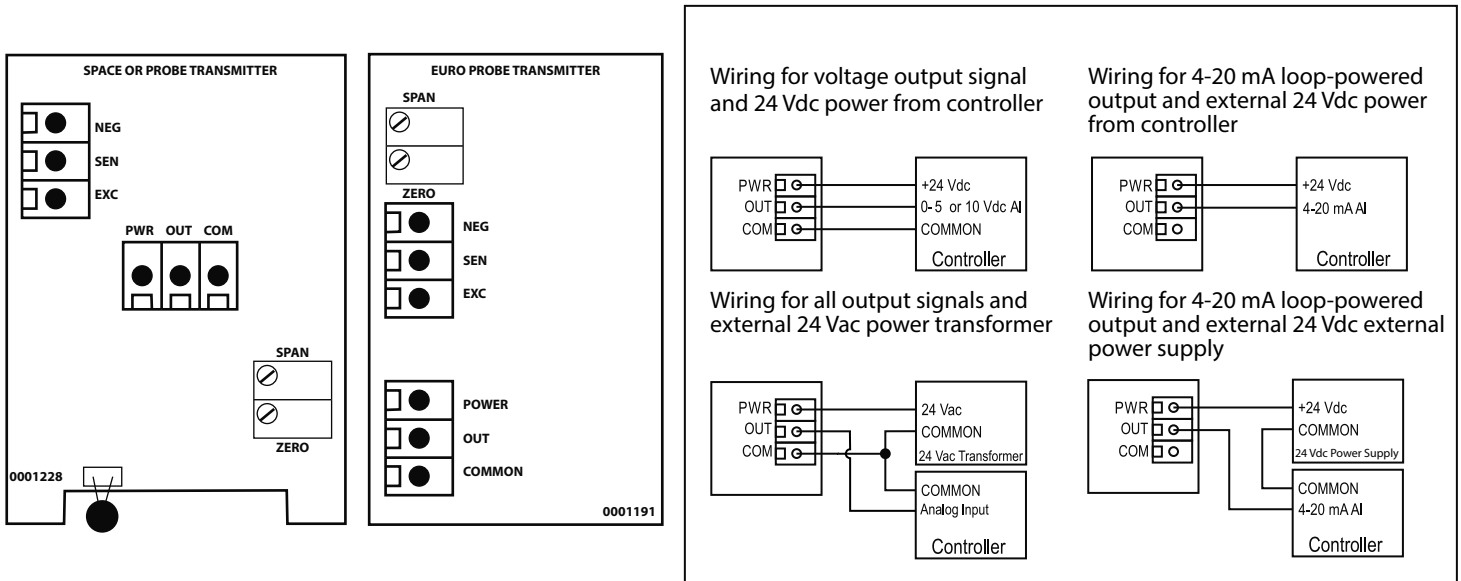

### Operation

The product should be allowed to warm-up for several minutes before attempting to verify accuracy. Allow the transmitter to operate for 20 minutes before any calibration is performed.

The calibrated range of the transmitter is written on the board. Operation can be verified by measuring the output signal. For voltage output models, measure the voltage between the OUT and COM terminals. The voltmeter should read between 0-5 or 0-10 Vdc depending on the model. For current output models, insert a mA meter in series with the OUT terminal and it should read between 4 and 20 mA.

### Calibration

The unit can be calibrated in the field using precision resistance values equal to the zero and span of the temperature range. Simply replace the attached probe with the resistor, then adjust the ZERO and SPAN pots accordingly to obtain the correct output signal. Repeat the adjustments until both values are correct. For units with 3-wire sensors jumper the SEN and EXC terminals with a wire.