

ABS, Bracket Enclosures



Other Enclosure Styles

Metal Enclosure



Weatherproof Enclosure



Duct Temperature Sensor

Designed for single point monitoring. It is available with various probe lengths and enclosures to fit any application.

Specifications

Standard Lengths	2", 4", 6", 8", 12", 18"
Operating Temperature Range	-20 to 105 °C (-4 to 221 °F)
Cable Type	PVC insulated, parallel bonded (100 Ω, IC Sensors – FT-4)
Cable Type (Bracket only)	FT-6, plenum rated (CSA)
Wiring Connections	Pig Tail (2 or 3 wire)
Enclosures	ABS, Metal or Weatherproof
Sensor Types	100 Ω, 1K PT, 1K Nickel RTD's, 1801 Ω, 3K, 10K (type 2 & 3), 20K & 100K Thermistors, IC Sensors

Installation

The duct type probes are installed through a 1/4" hole in the side of the duct to monitor a single point temperature within the duct. Since the probes are tip sensitive, select a probe length that places the sensor well into the duct to avoid errors due to laminar flow. Install the probes in a straight section of duct away from heating, cooling or humidifier elements.

Typical Wire Resistance Values

When using low resistance sensors (i.e. 100 ohm RTD), long wire runs can add significant error to the readings. Use the following chart to determine errors due to wire resistance or consider using a 1000 ohm sensor or a transmitter for better accuracy. Locate the type of wire being used. Multiply the total length of the wire (distance from the controller to the sensor and back) by the number found in the following chart for total resistance.

GAUGE WIRE TYPE	18 AWG	22 AWG	24 AWG
STRANDED (OHMS/FOOT)	5.85 mΩ	14.75 mΩ	23.29 mΩ
SOLID (OHMS/FOOT)	6.4 mΩ	15.85 mΩ	25.72 mΩ

Wiring & Color codes

All two-wire sensors are polarity insensitive. The three-wire sensors have the following color code:

<u>Connection</u>	<u>Duct Wire Color</u>
EXCitation	RED
SENse	GREEN
NEGative	BLACK

To connect a three-wire sensor as a two-wire, tie the EXCitation and SENse lines together. All connections should be made using either butt-splices or soldering. The use of wire nuts is not recommended.

The BB Duct sensor uses the RED and BLACK wires for the sensor. The GREEN and WHITE wires are not used.

Specifications

Power Supply 24 Vdc \pm 20% or 24 Vac \pm 10%
 Consumption 22 mA maximum
 Output Signals 4-20 mA or 0-5 Vdc or 0-10 Vdc
 Output Drive 400 ohm max for current output
 5K ohm min for voltage output
 Accuracy \pm 0.1% FSO
 Operating Range 0-50 °C (32-122 °F), 5-95 %RH
 Wire Connections Screw terminal block (14-22 AWG)
 Sensor 1000 ohm RTD
 LCD Display 3 digit for 88.8 or 888 as necessary
 0.95" w x 0.45" h (24 x 11 mm)
 Enclosure 5.7" w x 3.95" h x 2.5" d
 (145 x 100 x 63 mm)

Wiring

Use shielded twisted pair wiring of at least 22 AWG for all connections and do not run the signal or power wires in the same conduit with wiring used to supply inductive loads such as motors. Disconnect the power supply before making any connections to prevent electrical shock or equipment damage. Make all connections in accordance with national and local electrical codes.

The transmitter is available with either 4-20 mA, 0-5 Vdc or 0-10 Vdc output signals. Follow the example wiring diagrams to determine the correct wiring for the product. All models have the same terminal functions. For 4-20 mA loop powered operation, only **POWER** and **OUTPUT** are required. The **COMMON** terminal is only used for voltage output types or for AC power.

Ensure the controller Analog Input (AI) matches the transmitter output signal type before power is applied. The device is reverse voltage protected and will not operate if connected backwards. The voltage output signal has a minimum load that it is able to drive and the current signal has a maximum load. Follow the ratings in the Specification section or inaccurate readings may result.

If the transmitter has a dual sensor probe, connect the RTD (Red/Black) leads to the **SENSOR** terminals. The second sensor is Green/White.

Operation

The product should be allowed to warm-up for several minutes before attempting to verify accuracy. Allow the transmitter to operate for 20 minutes before any calibration is performed.

Operation can be verified by measuring the output signal. For voltage output models, measure the voltage between the **OUTPUT** and **COMMON** terminals. The voltmeter should read between 0-5 or 0-10 Vdc depending on the model. For current output models, insert a mA meter in series with the **OUTPUT** terminal and it should read between 4 and 20 mA. The LCD will indicate the same temperature value as the output signal.

Calibration

The unit can be calibrated in the field using precision resistance values equal to the zero and span of the temperature range. Simply replace the attached probe with the resistor, then adjust the **ZERO** and **SPAN** pots accordingly to obtain the correct output signal and display value. Repeat the adjustments until both values are correct.

Loop Powered Connection With Controller 24 Vdc Power

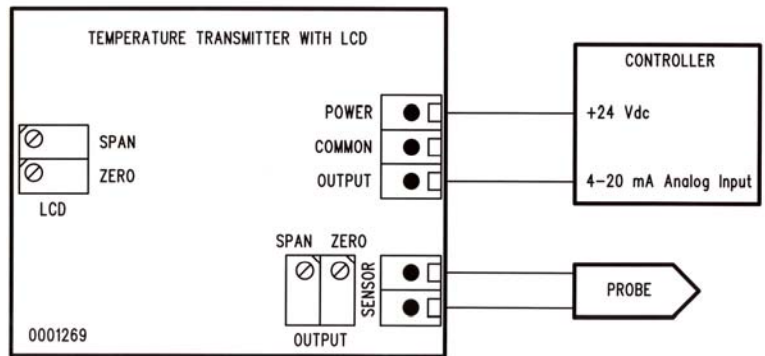

4-20 mA Connection With 24 Vac Power

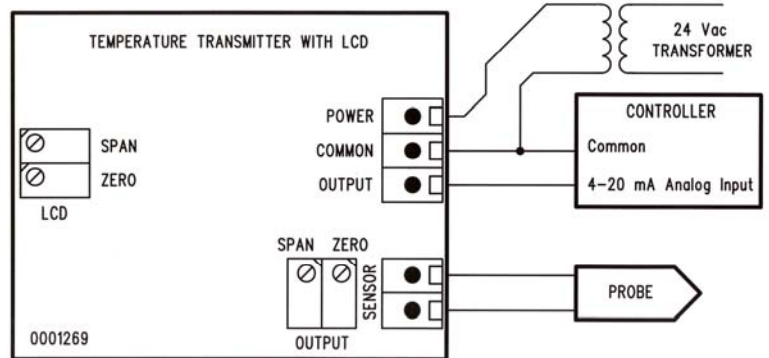

0-10 Vdc Connection With Controller 24 Vdc Power

