

# Slab Temperature Sensor

## Installation Instructions

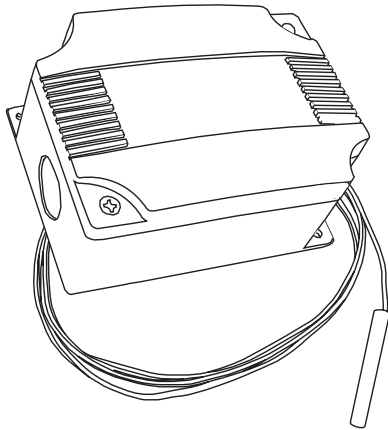

### INTRODUCTION

The slab temperature sensor is a single point temperature sensor that utilizes a precision sensor encapsulated in a thermal conductive coating and used to measure the temperature of a concrete slab. They are available with various sensor types, wire types and lengths. All probes are constructed to provide excellent heat transfer, fast response and to resist moisture penetration.

### BEFORE INSTALLATION

Read these instructions carefully before installing and commissioning the temperature sensor. Failure to follow these instructions may result in product damage. Do not use in an explosive or hazardous environment, with combustible or flammable gases, as a safety or emergency stop device or in any other application where failure of the product could result in personal injury. **Do not exceed the device ratings.**

### MOUNTING

Typically a predetermined area is defined where the temperature reading is required. During concrete installation a sufficient length of conduit or copper tubing is imbedded from this point to an area that will be accessible once complete.

At the entrance to the sensor chamber, unravel the slab sensor and carefully insert sensor and feed into the chamber until the chamber end is reached.

Secure the enclosure with (2) #10 x 25 mm (1") self tapping screws (not provided). Using a Phillips screwdriver, remove the (2) screws, as shown in Figure 3. Remove cover and set aside with screws for re-installing after wiring and set up.

A 21 mm (0.8125") hole provided for connection to a 12.77mm (0.5") EMT or cable gland style connector. Insert the EMT or cable gland connector through the hole and securely fasten using a locknut as shown in Figure 3. Make wire connections as per the "Wiring" illustrations on Page 2.

Once wiring and set up are complete, re-install cover and tighten the (2) screws using a Phillips screwdriver.

Figure 1

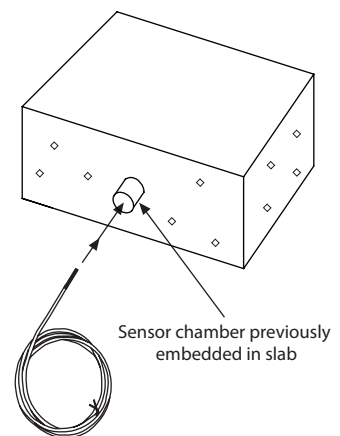

Figure 2

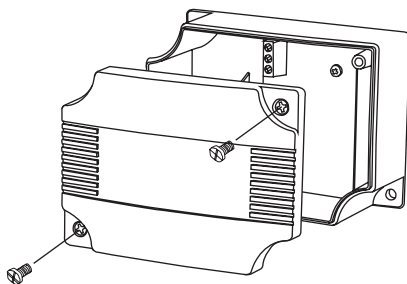
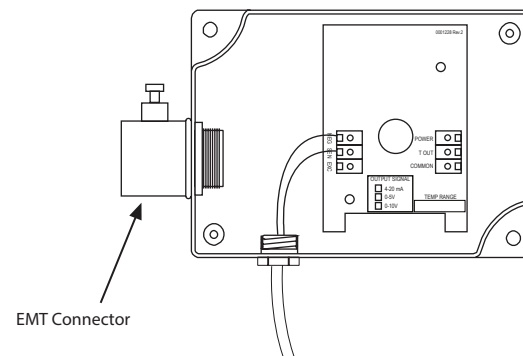
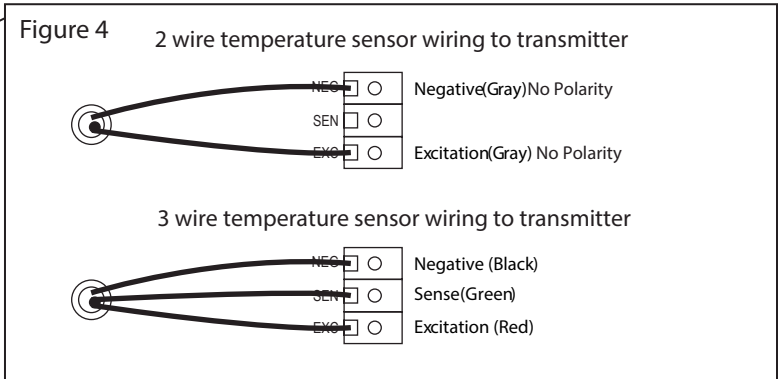
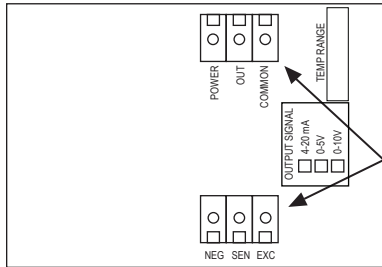

Figure 3



# WIRING

- Deactivate the 24 Vac/dc power supply until all connections are made to the device to prevent equipment damage.
- Use 14-22 AWG shielded wiring for all connections and do not locate the device wires in the same conduit with wiring used to supply inductive loads such as motors. Make all connections in accordance with national and local codes.
- The temperature transmitter comes with the temperature sensor pre-wired to the transmitter board. If removal is required for installation then it may be re-wired as shown in Figure 4.
- Pull at least six inches of control wire into the enclosure, then complete the wiring connection according to the wire diagram for the applicable power supply and output signal type as shown in Figure 5.
- Connect the DC positive or the AC voltage hot side to the PWR terminal. For voltage output or AC power, the supply Common is connected to the COM terminal. The device is reverse voltage protected and will not operate if connected backwards. It has a half-wave power supply so the supply Common is the same as the signal Common. See Figure 5.
- The analog output is available on the OUT terminal. Check the controller Analog Input to determine the proper connection before applying power as shown in Figure 5.
- Once all connections are made and checked, power can be applied.



## SPECIFICATIONS:

Sensor Type ..... 1000 ohm Platinum RTD  
 Sensor Accuracy.....±0.3°C (±0.94°F) @ 0°C (32°F)  
 Probe Sensing Range.....-20 to 60°C (-4 to 140°F)  
 Wire Material.....Various (See ordering chart)  
 Wire Length.....Various (See ordering chart)  
 Output Signal.....4-20 mA current loop, 0-5 Vdc, or 0-10 Vdc (factory configured)  
 Transmitter Accuracy .....±0.1% of span, including linearity  
 4-20 mA loop power supply... 15-35 Vdc or 22-32 Vac  
 Minimum Loop Current .....2 mA nominal (occurs with shorted sensor)  
 Maximum Loop Current.....22.5 mA nominal (occurs with open sensor)  
 Maximum Loop Load.....>600 ohms  
 0-5 Vdc Power Supply ..... 10-35 Vdc or 10-32 Vac  
 0-10 Vdc Power Supply..... 15-35 Vdc or 15-32 Vac  
 Maximum Current (Voltage)...5 mA nominal  
 Maximum Output (Voltage) ... Limited to <5.5 Vdc for 0-5 Vdc, <10.5 for 0-10 Vdc  
 Input Voltage Effect.....Negligible over specified operating range  
 Protection Circuitry.....Reverse voltage protected and output limited  
 Ambient Operating Range.....0 to 50°C (32 to 122°F), 0 to 95 %RH non-condensing  
 Enclosure.....ABS, UL94-V0, IP61 (NEMA 2)  
 Wiring Connections.....Screw terminal block (14 to 22 AWG)  
 Country of Origin.....Canada

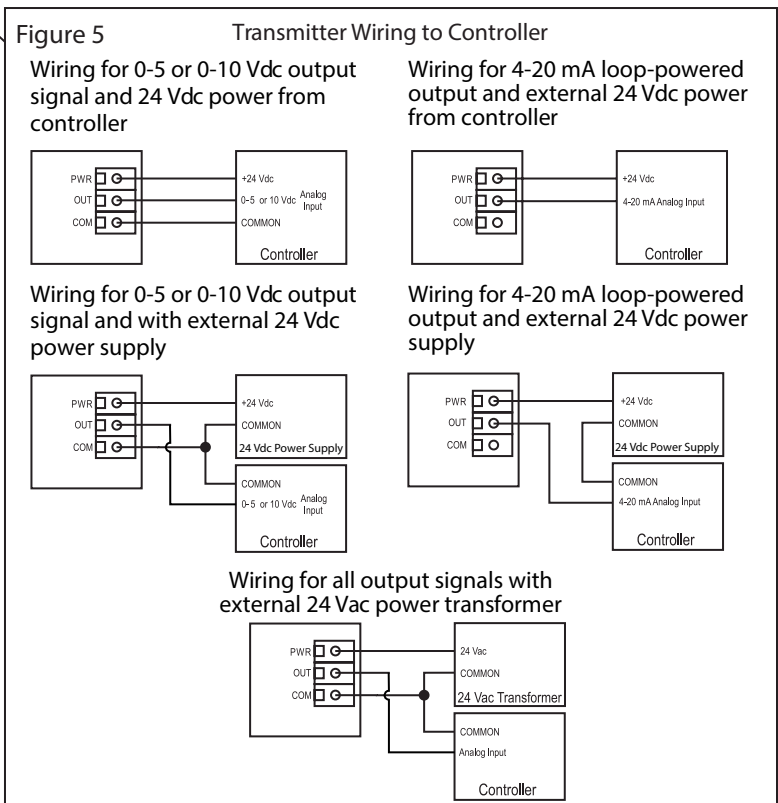

## DIMENSIONS

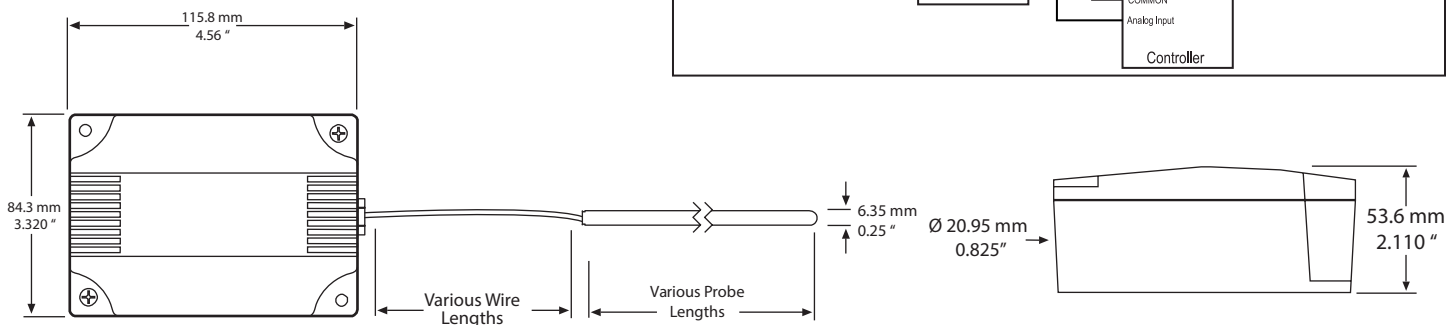

PRINTED IN CANADA