

Current Switch

Installation Instructions

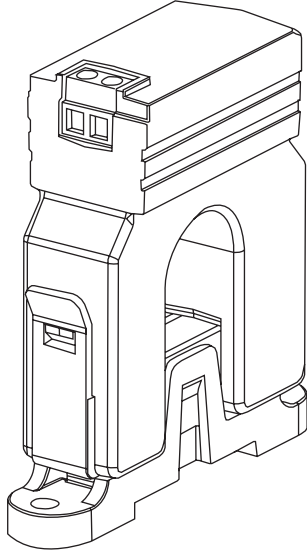

INTRODUCTION

The current switch monitors line current for electrical loads such as pumps, conveyors, machine tools or fans and closes the output contacts when the trip point is exceeded. The trip point is factory set to 2 Amps to provide Go/No Go status operation.

The sensor requires no external power as it is totally powered by induction from the AC line being monitored. The output switch is normally open and when the input current exceeds the trip setpoint of 2 Amps the switch closes to provide an on/off digital signal to the controller.

WARNING

- **Electric shock hazard, use caution**

- Disconnect and lock out power before installation
- Follow national and local electrical codes
- Read and understand these instructions before installing
- Installation only by qualified electrical personnel
- Do not rely on this device to indicate line power
- Only install this device on insulated conductors
- Only install on 600 Vac maximum conductors
- Do not use this device for life-safety applications
- Do not install in hazardous or classified locations
- Install this product in a suitable electrical enclosure
- **Failure to follow these instructions will result in death or serious injury**

MOUNTING

Read all warnings before beginning installation of this device. Ensure the selected device has the correct ratings for the application.

Disconnect and lock out power. To mount the device on a flat surface, select an area that will allow side and top access to wire device. If pre-drilling is required, the actual device may be used to mark holes on the selected surface. The mounting holes in the base will accommodate up to a # 10 size screw (not supplied). The base of the device may be removed for ease of installation. See Figure 1.

For DIN rail mounting, hook one side to the DIN rail and snap onto the rail, see Figure 1.

Open the SC-GNG by slightly pulling the tab and pulling upward and swiveling the device. See Figure 2. Place around the monitored conductor and close while keeping the sensor contacts clean, remove any dirt or debris. See Figure 3.

Wiring the output to the controller as shown in Figure 4.

Once all connections are made and verified, reconnect the power to the device.

Figure 1

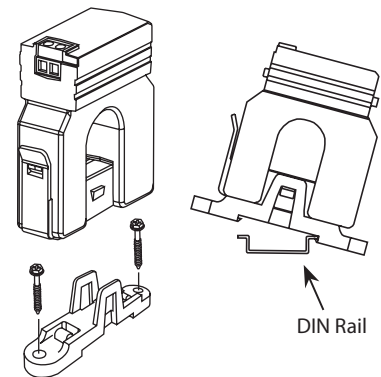

Figure 2

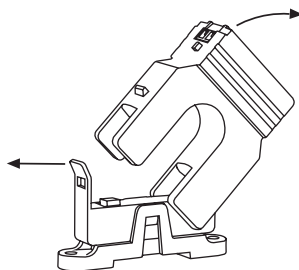

Figure 3

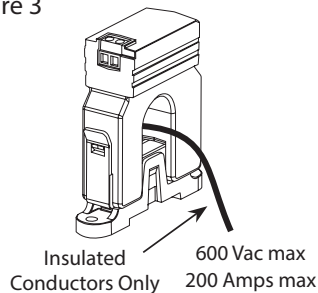
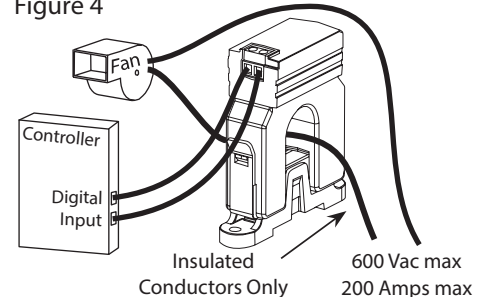

Figure 4



APPLICATIONS

For applications with load currents exceeding the sensor current range use an external CT to reduce the current to an acceptable value. For example, to monitor a 500 Amp load current, use a 500A:5A CT and wrap the CT secondary through the sensor four times so the sensor actually only sees 20 Amps when the load current is 500 Amps.

For applications with very small load currents (such as less than 2 Amps), wrap the monitored conductor through the sensor aperture several times to increase the current measured by the sensor. For example, to monitor a 0-1 Amp load with the sensor, wrap the conductor through the sensor 5 times so the sensor actually sees 0-5 Amps.

For any application with multiple wraps, note that the sensor maximum current rating must be divided by the number of wraps. For example, with one wrap the maximum current is 200 Amps, with 5 wraps the maximum current is $200/5 = 40$ Amps. Ensure the load current is < 40 Amps or the device may overheat and be damaged.

SPECIFICATIONS

Current Setpoint	Fixed at 2 Amps
Maximum Input Current	200 Amps continuous
Sensor Power	Self-powered
Output Type	Solid-state mosfet
Output Switch Action	Normally open
Output Switch Ratings	30 Vac/dc, 500 mA maximum
Von @ 24 Vdc @ 500 mA	< 50 mV
Frequency	50/60 Hz
Response Time	200 mS typical
Insulation Class	600 Vac, insulated conductors
Operating Temperature	-15 to 50°C (5 to 122°F)
Operating Humidity	5 to 90 %RH, non-condensing
Terminal Block	14to 22 AWG
Dimensions	76mm W x 79mm H x 24.9mm D (3.0" x 3.1" x 0.98")
Sensor Aperture	20.3mm (0.8")
Enclosure	ABS/PC, UL94 V-0
Manufacturing	ISO 9001 Certified
Agency Approvals	cULus Listed
Country of Origin	Canada

DIMENSIONS

