

# Duct RH/T Transmitter

## RH210 Series

### Installation Instructions

#### Introduction

The RH series uses a highly accurate and reliable Thermoset Polymer based capacitance humidity sensor and Platinum RTD temperature sensor together with state-of-the-art digital linearization and temperature compensated circuitry to monitor humidity levels in a duct. The sensors are encapsulated in a 60 micron HDPE filter at the end of a 230 mm (9") S/S probe and a compact enclosure.

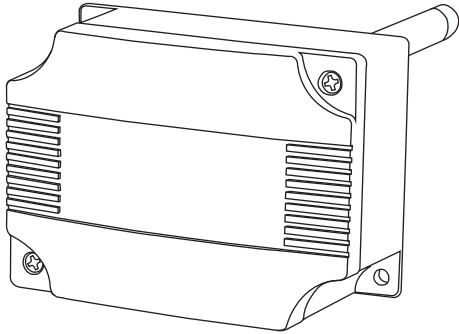

#### Before Installation

Read these instructions carefully before installing and commissioning the RH transmitter. Failure to follow these instructions may result in product damage. Do not use in an explosive or hazardous environment, with combustible or flammable gases, as a safety or emergency stop device or in any other application where failure of the product could result in personal injury. **Take electrostatic discharge precautions during installation and do not exceed the device ratings.**

#### Mounting

The transmitter installs directly into any air duct with a minimum width/diameter of 25.5 cm (10"). Select a suitable installation area in the middle of the duct wall. To achieve the best reading, do not place in an area where air stratification may be present. **Mount the sensor at least 1.5 m (5') in either direction from elbows, dampers, filters or other duct restrictions. Avoid areas where the transmitter is exposed to vibrations or rapid temperature changes.**

Once a suitable spot is selected, drill a 15 -20 mm (0.6" - .75") hole for the probe.

Slide the probe in the drilled hole until the enclosure is flush against the duct. The airflow direction is not important. Secure the enclosure to the duct with (2) #10 x 1" (25 mm) self tapping screws (Not provided). Tighten screws until the enclosure is tight against the duct and that there is no movement of the enclosure as shown in Figure 1.

A foam gasket is provided on the back of the enclosure that provides a tight seal against any air leaks.

Using a Phillips screwdriver, remove the (2) screws, as shown in Figure 2. Remove cover and set aside with screws for re-installing after wiring and set up.

Two 21 mm (0.8125") holes are provided for connection of either 12.77mm (0.5") EMT or a cable gland style connector as shown in Figure 3. Insert the EMT or cable gland connector through the hole and securely fasten using a locknut. If only one connection hole is required, use the included hole cap to cap off the unused one as shown in Figure 4.

**Special care must be taken not to damage any internal components during installation.**

Make wire connections as per the "Wiring" illustrations on Page 2.

Once wiring and set up are complete, re-install cover and tighten the (2) screws using a Phillips screwdriver.

Figure 1

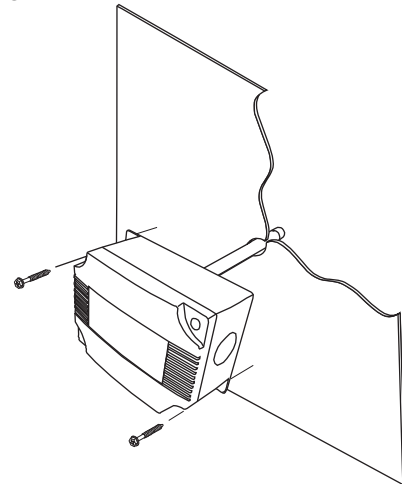

Figure 2

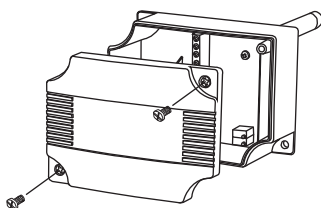

Figure 3

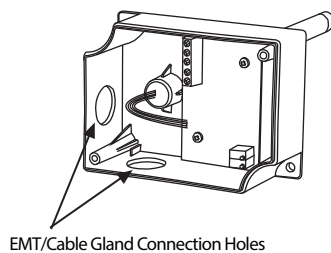
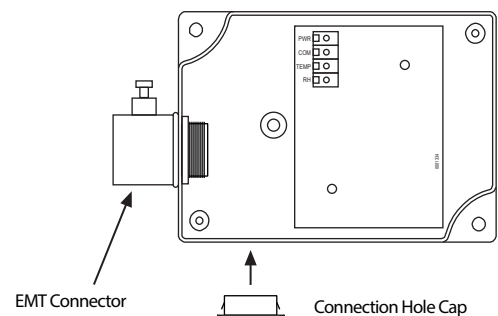
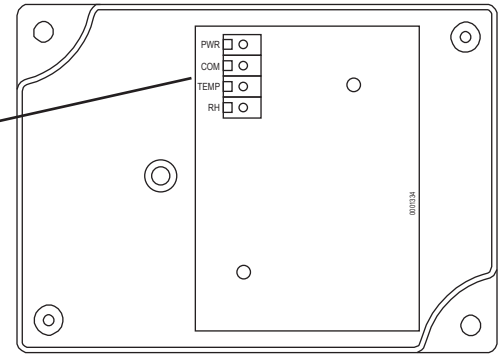
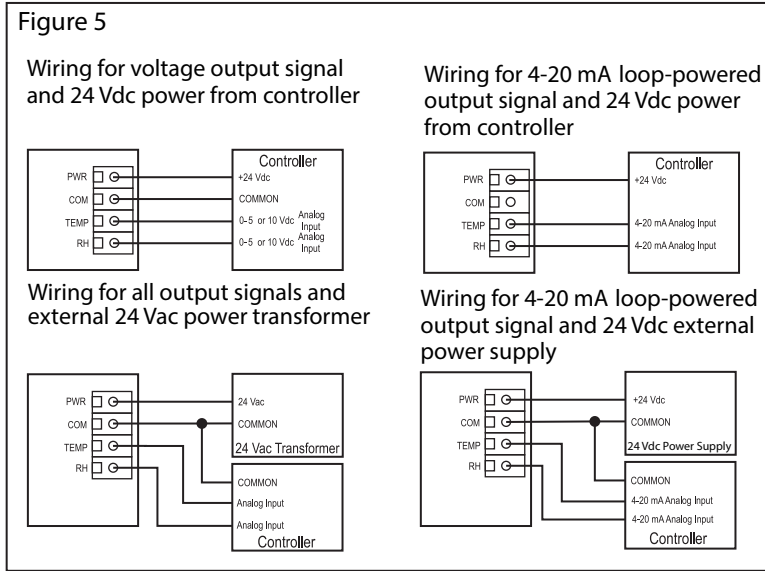

Figure 4



### Wiring

- Deactivate the 24 Vac/dc power supply until all connections are made to the device to prevent electrical shock or equipment damage.
- Use 14-22 AWG shielded wiring for all connections and do not locate the device wires in the same conduit with wiring used to supply inductive loads such as motors. Make all connections in accordance with national and local codes.
- Pull at least six inches of wire into the enclosure, then complete the wiring connection according to the wiring diagram for the applicable power supply and output signal type.
- Connect the plus DC or the AC voltage hot side to the PWR terminal. For voltage output or AC power, the supply Common is connected to the COM terminal. The device is reverse voltage protected and will not operate if connected backwards. It has a half-wave power supply so the supply Common is the same as the signal Common. See **Figure 5**.
- The analog outputs are designated as TEMP and RH by each terminal. Check the controller Analog Input to determine the proper connection before applying power. See **Figure 5**.



### Specification:

- Humidity Sensor Type:.....Thermoset polymer based capacitive
- Accuracy at 25°C:.....±2%, 3% or 5% RH (5% to 95% RH)
- Measurement Range:.....0 to 100% RH
- Hysteresis:.....±1.5% RH maximum
- Stability:.....±1% RH typical at 50% RH in 5 yrs.
- Sensor Response Time:.....15 seconds typical
- Temperature Sensor Type:.....1000 Ω Platinum IEC751, 385 Alpha
- Temp. Sensor Accuracy: .....±0.3°C @ 0°C
- Temp. Transmitter Accuracy:.....±0.25% of span
- Operating Temperature:.....-40° to 70°C (-40° to 158°F)
- Operating Humidity:.....0 to 95% RH non-condensing
- Power Supply:.....18 to 30 Vdc, 15 to 26 Vac
- Consumption:.....40 mA maximum
- Input Voltage Effect:.....Negligible over specified operating range
- Protection Circuitry:.....Reverse voltage protected and output limited
- Output Signal:.....4-20 mA current loop, 0-5 or 0-10 Vdc
- Output Drive at 24 Vdc:.....550 ohms max for current output  
10K ohms min for voltage output
- Wiring Connections:.....Screw terminal block (14 to 22 AWG)
- Enclosures:.....ABS, UL94-V0, IP61 (NEMA 2)

### Dimensions:

