

Room Humidity Transmitter

Installation Instructions

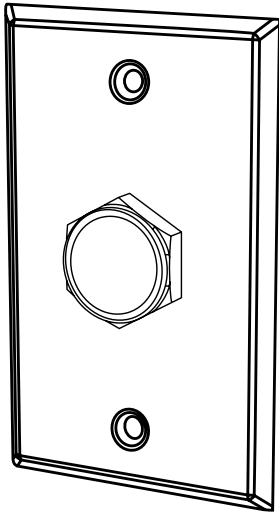

INTRODUCTION

The stainless steel wall plate relative humidity transmitter uses a highly accurate and reliable thermoset polymer based capacitance humidity sensor and temperature compensated circuitry to measure indoor humidity levels. The watertight wall plate sensor is perfect for wash-down locations and features a 304 series stainless steel plate with a 100 micron sintered stainless steel filter.

BEFORE INSTALLATION

Read these instructions carefully before installing and commissioning the humidity transmitter. Failure to follow these instructions may result in product damage. Do not use in an explosive or hazardous environment, with combustible or flammable gases, as a safety or emergency stop device or in any other application where failure of the product could result in personal injury. Take electrostatic discharge precautions during installation. **Do not exceed the device ratings.**

MOUNTING

The stainless steel plate type sensor installs directly on a standard electrical box and should be mounted five feet from the floor of the area to be controlled. Do not mount the sensor near doors, opening windows, supply air diffusers or other known air disturbances. Avoid areas where the sensor is exposed to vibrations or rapid temperature changes.

This device has been designed for use in wash-down areas. Prior to washing the area the sensor filter must be protected with the supplied plastic cap. The cap is designed to simply fit over the filter and will prevent spray from entering the sensor area. **Failure to use the protective cap will result in premature sensor failure and will void the warranty.**

Before mounting the enclosure, first complete the wiring instructions on page two. Once complete, mount the stainless steel plate to the electrical box using the provided screws as illustrated in Figure 2.

Figure 1

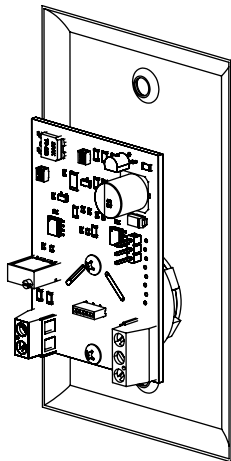
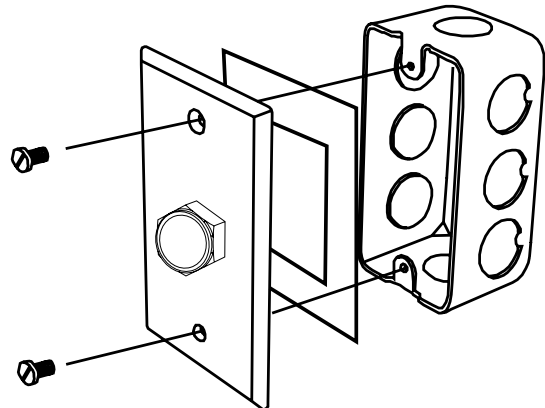

Figure 2



WIRING

- Deactivate the 24 Vac/dc power supply until all connections are made to the device to prevent electrical shock or equipment damage.
- Use 22 AWG shielded wiring for all connections and do not locate the device wires in the same conduit with wiring used to supply the inductive loads such as motors. Make all connections in accordance with national and local codes.
- Pull at least six inches of wire through the wall and out of the junction box, then complete the wiring according to the wire diagram for the applicable power supply and output signal type.
- Connect the plus dc or the ac voltage hot side to the PWR terminal. For voltage output or ac power, the supply common is connected to the COM terminal. The device is reverse voltage protected and will not operate if connected backwards. It has a half-wave power supply so the supply common is the same as the signal common.
- The analog output is available on the OUT terminal. Check the controller analog input to determine the proper connection before applying power.
- If installed, the resistance temperature signal is available on the two terminals labeled TEMP.

RH OFFSET

To adjust RH reading, place jumper in OFFSET position (bottom two pins of JP1A). Adjust POT P1 to change RH reading to desired value. Place jumper back to original position (Top two pins of JP1A) once reading is adjusted.

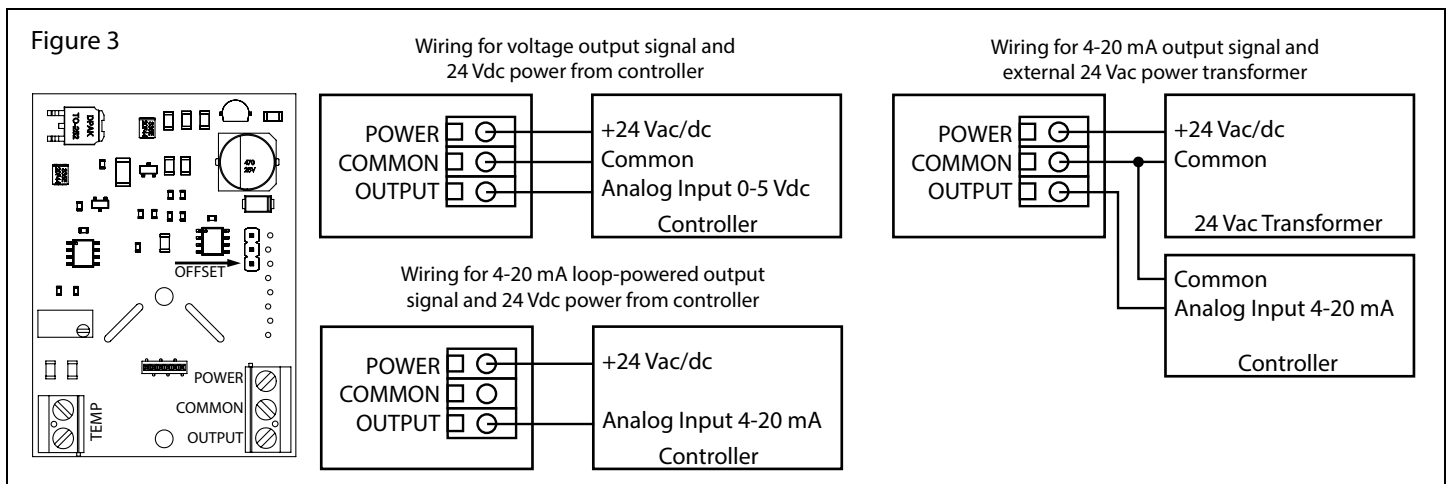
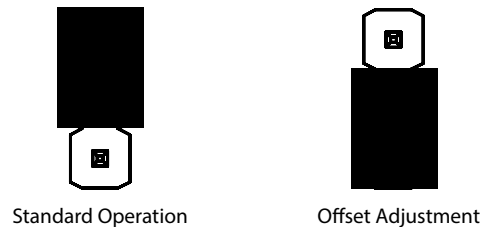

SPECIFICATIONS

Power Supply.....	18-35 Vdc, 20-26 Vac
Output Signal.....	Current: 4-20 mA loop Voltage: 0-5 or 0-10 Vdc
Output Drive	Current: 550 Ω max Voltage: 10K Ω min
Operating Temperature.....	0 to 50°C (32 to 122°F)
Operating Humidity	0 to 95 %RH non-condensing
Accuracy	±2, 3 or 5 %RH
Measurement Range.....	0 to 100 %RH
Sensor Protection.....	100 micron sintered filter
Resolution	± 0.01 %RH
Hysteresis	± 0.8 %RH @ 25°C (77°F)
Sensor Response Time.....	8 seconds
Stability	<0.25 %RH/year
Temperature Sensor	Various RTD's and thermistors
Wiring Connections.....	Screw terminal block (14 to 22 AWG)
Internal Adjustments	Offset Pot -10% to +10%
Country of Origin.....	Canada

DIMENSIONS

