

Outside Particulate Matter Transmitter

Installation Instructions

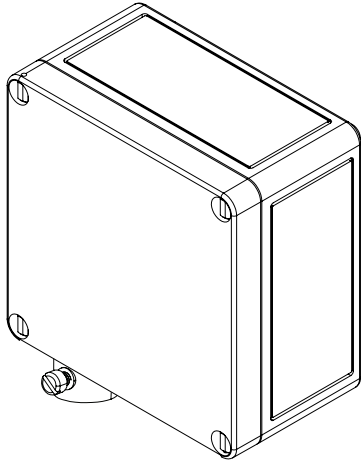

INTRODUCTION

The Outside Particulate Matter Sensor uses an optical sensor based on laser scattering principles and features innovative contamination-resistance technology to perform highly accurate and reliable PM measurements. With a continuous-operation lifetime of more than 8 years, the sensor will provide long-term reliability and high-resolution particle size binning for the detection of environmental dust and other particles.

The sensor is housed within a weatherproof enclosure to monitor outside PM levels. The sensor achieves excellent performance characteristics, including high accuracy and low power consumption to ensure stable long-term operation. The outside particulate sensor features both 4-20 mA and voltage outputs (0-5 / 0-10 Vdc) for simple integration into any building automation system to assure good air quality. The device is also available with an RS-485 MS/TP network connection including either Modbus or BACnet® protocol.

BEFORE INSTALLATION

Read these installation instructions carefully before commissioning the sensor. Failure to follow these instructions may result in product damage. Do not use in an explosive or hazardous environment, with combustible or flammable gases, as safety or emergency stop devices or in any other application where failure of the product could result in personal injury. **Use electrostatic discharge precautions during installation and do not exceed the device ratings.**

MOUNTING

Select a suitable mounting spot on an exterior wall where the sensor is best protected from direct exposure to sunlight, wind, etc. preferably on a north facing wall. Do not mount the sensor near opening windows, supply/exhaust air louvres or other known air disturbances. Avoid areas where the sensor is exposed to vibrations or rapid temperature changes. It is recommended that the enclosure be mounted so conduit or cable-gland connections be made on the bottom of the enclosure. See Figure 1.

Remove the cover by using a standard or Phillips screwdriver to loosen the four screws as shown in Figure 2. As the screws are captive type, complete removal of the screw from the cover is not required.

Install a conduit connector or cable gland as shown in Figure 3. It is recommended that weatherproof conduit or cable gland fittings be used. The outside mount particulate sensor installs directly on an exterior wall using the four integrated mounting holes provided on the enclosure. See figure 4.

Figure 1

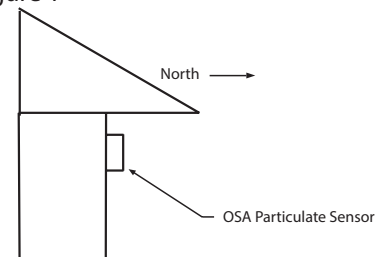

Figure 2

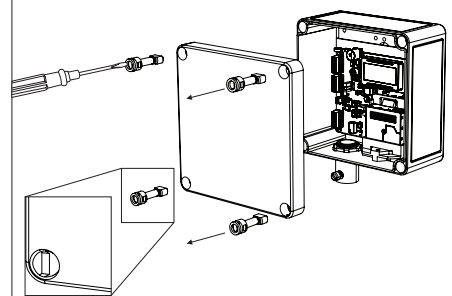

Figure 3

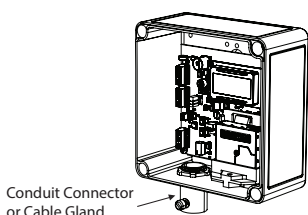

Figure 4

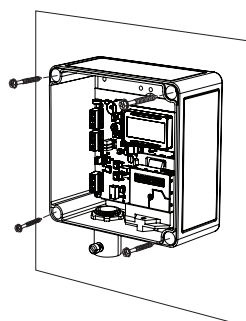
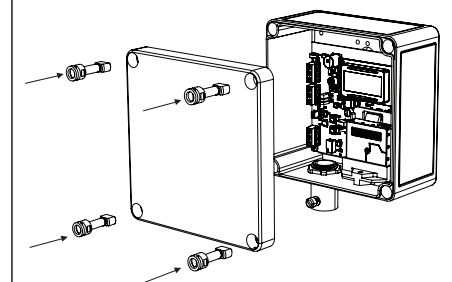

Figure 5



Select the best mounting technique based on the exterior wall material. The 4 mounting holes will facilitate a #10 size screw (not supplied). Mount the base by screwing directly to the wall. After the base is securely fastened to the exterior wall, connect conduit to conduit connector or feed cable through the cable gland and tighten. Make wire connections as per the "Wiring" illustrations. Once wiring and set up are complete, re-install cover and secure by tightening the four screws using a flat screwdriver. See Figure 5.

WIRING

The sensor has standard screw block connectors and easy wire access to facilitate wiring. It is recommended that shielded twisted pair wiring at least 22 AWG be used for all connections and that the device wires not be run in the same conduit with wiring used to supply inductive loads such as motors. Disconnect the power supply before making any connections to prevent electrical shock or equipment damage. Make all connections in accordance with national and local electrical codes.

The device should be connected to a 24Vac/dc, class 2 power supply. The PWR terminal is used for the positive DC voltage or the hot side of the AC voltage. The device is reverse voltage protected and as such will not operate if connected backwards.

The common of the power supply is connected to the terminal marked COM. Note that this device has a half-wave type power supply which means the power supply common is the same as the output signal common. Therefore, several devices may be connected to one power supply and the output signals all share the same signal common. Use caution when grounding the secondary of an ac transformer or when wiring multiple devices to ensure that the circuit ground point is the same on all devices and the controller. In general, the transformer should not be connected to earth ground when using devices with an RS-485 network connection.

The analog output signal is available on the OUT terminal. This signal is jumper selectable for either voltage or 4-20 mA output signal type. See Figure 6. The voltage output signal defaults to 0-5 Vdc but may be changed to 0-10 Vdc via the menu. These options are clearly indicated on the device PCB. The analog output signal is typically connected directly to the Building Automation System (B.A.S.) and used as a control parameter or for logging purposes. Check the controller Analog Input type to determine the correct connection and signal type before applying power. The device generates the analog output signal (sourcing) and must not be connected to a powered input or device damage may occur.

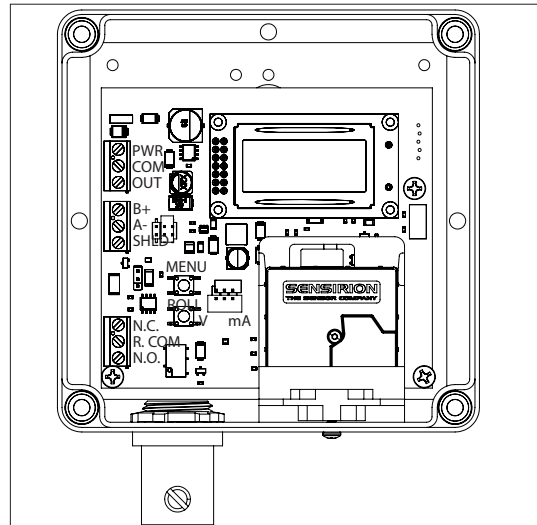

Figure 6

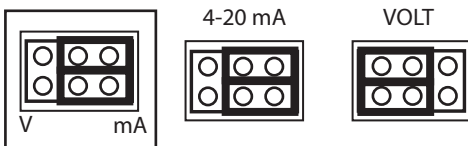
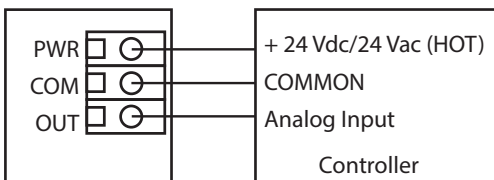

Figure 7



For voltage type output signal the device has a minimum load that it is able to drive, similarly for current type output signal the device has a maximum load that it is able to drive with a particular power supply voltage. Observe and follow these ratings in the Specification section or inaccurate reading may result. The 4-20 mA output signal can easily be converted to a 1-5 Vdc signal for controllers accepting this type of input. Simply insert a 250 ohm (0.1% is best) resistor between the "+" and "-" inputs of the controller. This will convert the 4-20 mA signal to the desired 1-5 Vdc. See Figure 7.

If the device includes the optional network connection, use twisted shielded pair to connect to the terminals marked A-, B+ and SH (SHIELD). The positive wire connects to B+, the negative to A- and the cable shield must be connected to the SH terminal on each device. The shield wire should be connected to earth ground at one end of the network only. If the device is installed at either end of an RS-485 network, an end-of-line (EOL) termination resistor (121 Ω) should be installed in parallel with the A- and B+ terminals. See Figure 8. This device includes a network termination resistor and jumper that can be used to connect the EOL resistor on the PCB. Simply move the jumper to the EOL position and no external resistor is required. See Figure 9.

A network segment is a single shielded wire loop run between several devices (nodes) in a daisy chain configuration. The total segment length should be less than 1220 meters (4000 feet) and the maximum number of nodes on one segment length is 128. Nodes are any device connected to the loop and include controllers but do not include the EOL terminators. To install

more than 128 devices, or to increase network length, repeaters will be required for proper communication. The maximum daisy chain length (segment) depends on transmission speed (baud rate), wire size and number of nodes. If communication is slow or unreliable, it may be necessary to wire two daisy chains to the controller with a repeater for each segment.

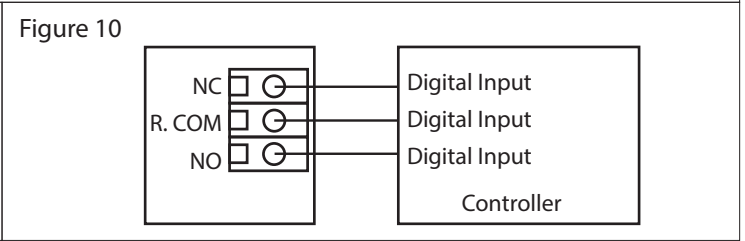
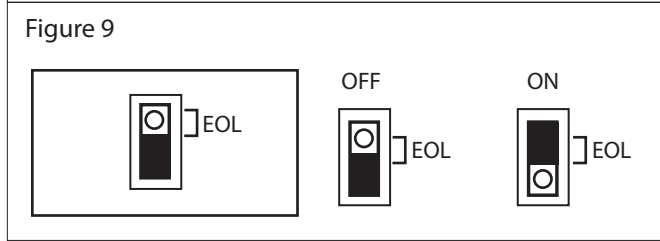
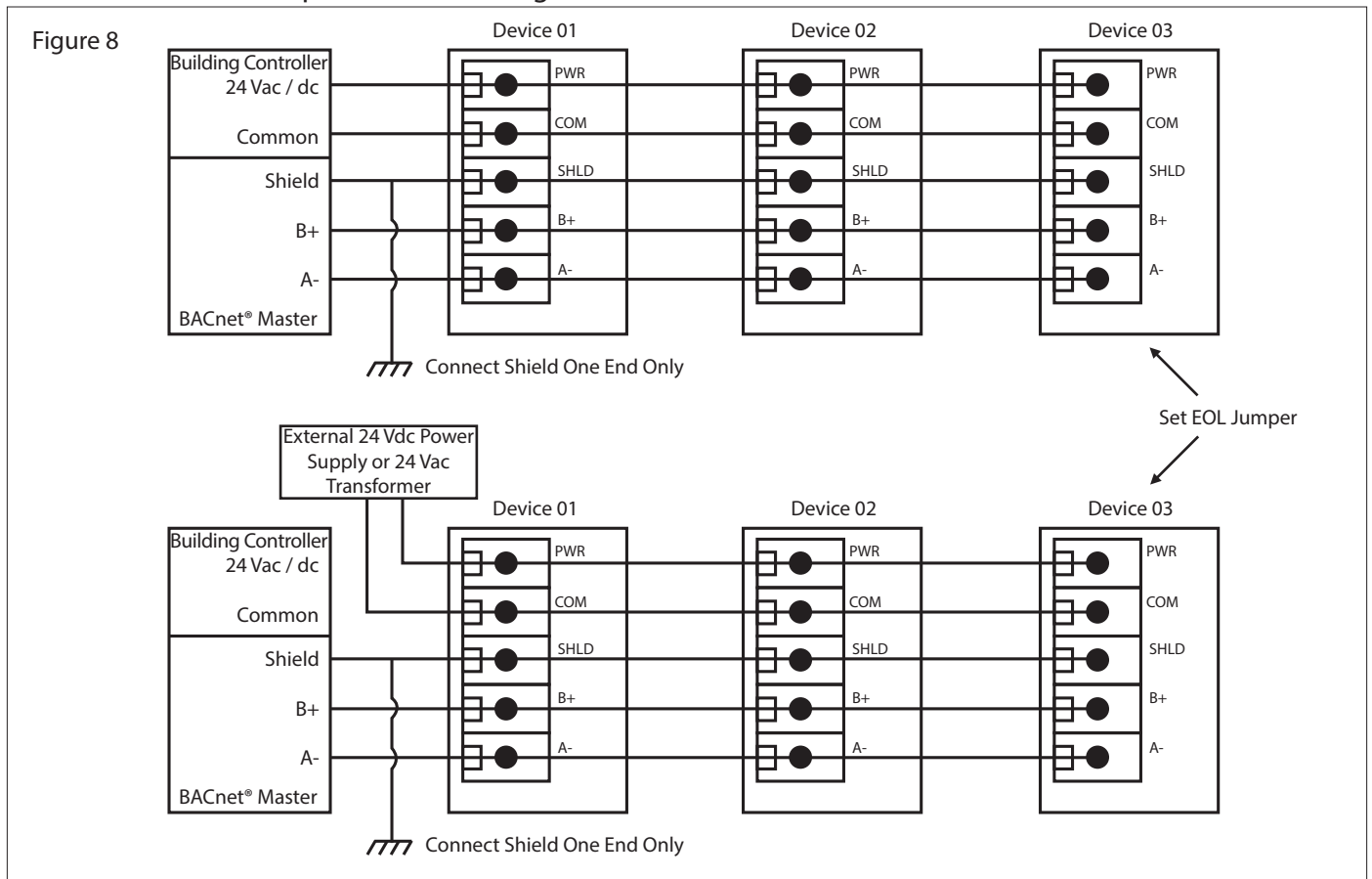

An optional signal is the alarm relay output available on the NO (NORMALLY OPEN), NC (NORMALLY CLOSED) and R.COM (RELAY COMMON) terminals. The R.COM terminal is not connected to the power supply COM terminal, the relay output is completely isolated. The relay contacts may be connected to a controller Digital Input (DI) for status monitoring or used to directly control an alarm or ventilation fan. Do not exceed the device contact ratings. In some cases, a separate control relay may be used between the PM sensor relay and a large fan for example. See Figure 10.

OPERATION - START-UP

After applying power to the device, it will enter the start-up mode and the LCD will indicate the software version number, the PM range, the PM alarm setpoint (if applicable) and the analog output type for two seconds each.



If the network option is installed, then the start-up sequence will also show the network protocol, the baud rate and the device address. Then the device will start normal operation and display the PM concentration value.



OPERATION - NORMAL

During normal mode the device reads the PM sensor and calculates the Air Quality Index based on a 24 hour time average. The real time PM concentration value is displayed on the LCD and set as the output value for the analog output. The output value is updated once per second. The LCD may be configured via the menu to display either the PM value or the AQI. If the optional tri-color LED is installed, it will change color to indicate Good (Green), Moderate (Yellow) or Poor (Red) air quality.

On start-up when the first readings are obtained, the Air Quality reading for the device averages the concentration level as necessary until the required time base setting is reached. For example, if only 10 readings are available then the output value is calculated as the average of those 10 readings. The next output value will be an average of 11 readings. This short-averaging will continue until the unit has been running for 24 hours. Once 24 hours is reached then the AQI value will always be the average of readings over the past 24 hours.

The device also monitors the keypad and takes appropriate menu actions for setup. The network version of the product allows for configuration of settings via BACnet® or Modbus protocol and the BACnet® objects or Modbus registers are updated with the appropriate values and alarm conditions are monitored.

OPERATION - ALARM

All models except for the analog output only without relay will have a PM setpoint alarm. The alarm will control the optional relay or network variables as applicable to the model. The PM alarm setpoint, hysteresis and time delay may be configured via the menu or network. The details of each setting and operation is explained in the Setup Menu section.

OPERATION - SETUP MENU

The Setup Menu has several items as shown below. To enter the menu, press and release the <MENU> key while in normal operation. This will enter the Setup Menu step 1, pressing the <MENU> key a second time advances to step 2. Each press of the <MENU> key saves the selection and advances the menu item. The <ROLL> key is used to make changes to program variables by scrolling through the available options. If the Setup Menu is not active for 5 minutes (no key press), then the menu will exit and the device returns to normal operation.

<MENU> Press and hold to enter the setup menu. Once in menu release <MENU>.

1. PARTICULATE MATTER RANGE

PM Range
PM10

The default PM Range is PM10. Use <ROLL> to change the range as required to either PM1.0, PM2.5, PM4.0, or PM10.

<MENU> Press to advance to next menu item

2. VOLTAGE OUTPUT SIGNAL

Output
0-5 Vdc

Use <ROLL> to set the voltage output signal type to 0-5 or 0-10 Vdc. The factory default is 0-5 Vdc.

<MENU> Press to advance to next menu item

3. ANALOG OUTPUT

Output
Direct

The analog output defaults to Direct (4-20 mA, 0-5 Vdc or 0-10 Vdc). Use <ROLL> to change it to Reverse (20-4 mA, 5-0 Vdc or 10-0 Vdc) if required.

<MENU> Press to advance to next menu item

4. ANALOG OUTPUT SCALE

Scale
1000 ug

The default analog output scale is 0-1000 ug/m³. The maximum value can be changed from 500 to 1000 (resolution 100) using <ROLL> if required. For example, the output can be 4-20 mA = 0-700 ug/m³.

<MENU> Press to advance to next menu item

5. DISPLAY INFORMATION

Display
ug/m³

Use <ROLL> to configure the display information as Mass Concentration in ug/m³ or as an Air Quality Index (0-500 AQI / GOOD, MODERATE, POOR). The display will change from ug/m³ to AQI.

<MENU> Press to advance to next menu item

6. BACKLIGHT

Backlite
Auto

The backlight operation defaults to Auto operation. It can be set to Off or On using <ROLL>. Auto means the LCD backlight only lights when a menu is accessed, off means it never lights and on means it is always on.

<MENU>

Press to advance to next menu item

Only if **Relay OR Network Option** installed

(there is no PM alarm for the analog only model with no relay)

7. SETPOINT ALARM

PM Alarm
150 ug

Setpoint for PM alarm and relay (if installed) activation. Default setpoint for alarm activation is 150 ug/m³. Use <ROLL> to adjust from 50-900 ug/m³. Resolution is 10 ug/m³.

<MENU>

Press to advance to next menu item

8. ALARM HYSTERESIS

Alrm Hys
20 ug

The default PM alarm hysteresis is 20 ug/m³. Use <ROLL> to change to 10, 15, 20, 25, 30, 35 or 40 ug/m³. If the PM Alarm setpoint = 150 and hysteresis = 20, then the alarm will be set if the PM exceeds 150 and will reset when it falls below 130.

<MENU>

Press to advance to next menu item

9. ALARM DELAY

Alrm Dly
0 min

The default PM alarm delay is 0 minutes. Use <ROLL> to change from 0 to 10 minutes to prevent false alarms. Resolution is 1 minute.

<MENU>

Press to advance to next menu item

10. PM ALARM

PM Alarm
Test Off

The default PM alarm test is Off. Use <ROLL> to toggle it Off or On. When set to On, an alarm condition is forced for testing purposes. If a relay is installed it will also be activated. The alarm condition will be reset to Off.

<MENU>

Press to advance to next menu item

Only if **Network Option** installed

11. BAUD RATE

BaudRate
9600

The default network baud rate is 9600. Use <ROLL> to select 9600, 19200, 38400, 57600, 76800 or 115200 as required.

<MENU>

Press to advance to next menu item

12. ADDRESS

Address
3

The default network address is 3 for BACnet® and 1 for Modbus. Use <ROLL> to select 0-127 for a BACnet® device or 1-255 for a Modbus device.

<MENU>

Press to advance to next menu item

Only if **Modbus Option** installed

13. PARITY VALUE

ModBus
Parity N

Use <ROLL> to select a parity value of N (none), O (odd) or E (even). The factory default Modbus parity bit is N (none).

<MENU>

Press to advance to next menu item

14. STOP BITS

ModBus
Stop 1

Use <ROLL> to toggle the stop bits between 1 and 2. The default Modbus stop bits is 1.

<MENU>

Press to advance to next menu item

15. CRC VALUE

ModBus
CRC A001

Use <ROLL> to set the CRC value to A001 (CRC-16 reverse), 1021 (CITT), 8005 (CRC-16) or 8408 (CITT reverse). The default CRC polynomial is 0xA001.

<MENU>

Press to advance to next menu item

16. SLAVE RESPONSE

ModBus
CRC A001

Use <ROLL> to change the value from MIN (minimum) to 50, 100, 150, 200, 250, 300 or 350ms. The factory default slave response delay is minimum (minimum delay means just more than 3.5 character time delays, 4ms for 9600 baud rate, for example).

<MENU>

Exits the Setup Menu and returns to normal mode.

OPERATION - TESTING/COMMISSIONING (OPTIONAL)

To perform testing or commissioning the unit should be configured to display PM reading since AQI reading requires operation over 24-hour period. To verify sensor is reading properly a CO BUMP KIT or equivalent can be used to generate particulates.

To prepare for testing open CO BUMP KIT, follow instructions included with kit to generate smoke from wick. The CO Adapter is not required for testing the PM sensor.

Hold wick close to inlet of sensor (bottom of unit).

Sensor PM reading should increase.

This will verify sensor is reading higher PM levels and is operational. If sensor readings do not increase with smoke then sensor is faulty.

DIMENSIONS

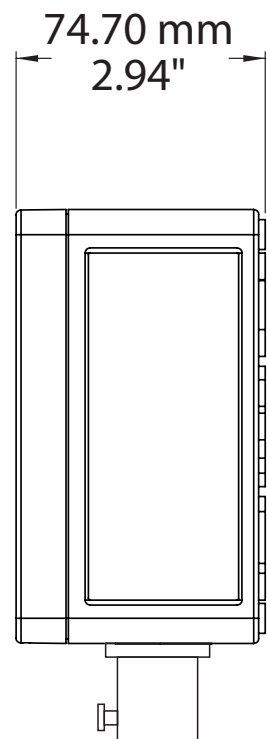
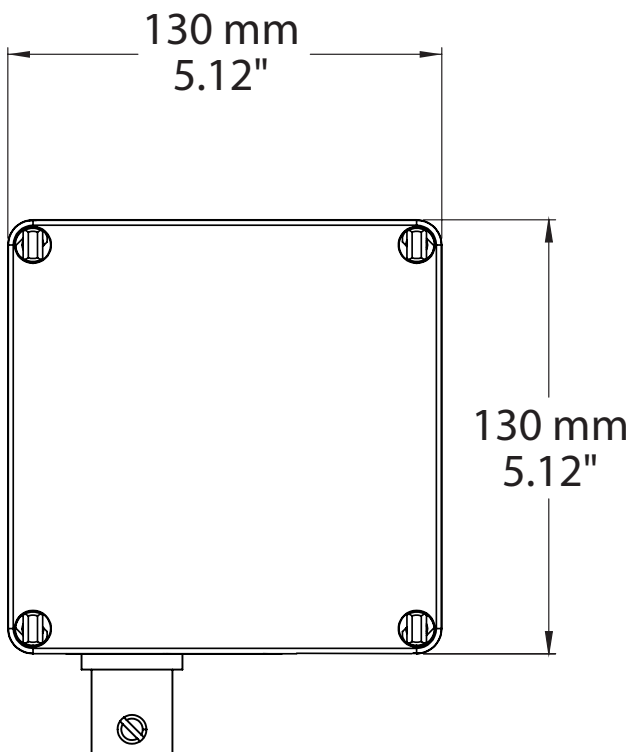

SPECIFICATIONS

PM Sensor

Sensor	Laser scatter method
Particle Size.....	PM1.0, PM2.5, PM4.0, PM10 (selectable)
Mass Concentration.....	0 to 1000 ug/m ³
Resolution	1 ug/m ³
Accuracy	±10 ug/m ³ (0 to 100 ug/m ³), ±10% (100 to 1000 ug/m ³)
Response Time	1 second
Sensor Lifetime	>8 years

Analog Model

Consumption	75 mA max @ 24 Vdc, 100 mA max @ 24 Vac
Output Signals.....	4-20 mA (sourcing) or 0-5 Vdc / 0-10 Vdc (selectable)
Output Drive Capability	Current: 550Ω max Voltage: 5,000Ω min
Output Scale	0 to 1000 ug/m ³ (menu selectable)

BACnet® Model

Consumption	50 mA max @ 24 Vdc, 80 mA max @ 24 Vac
Interface.....	MS/TP, 2-wire RS-485
Baud Rate	9600, 19200, 38400, 57600, 76800 or 115200 (menu selectable)
Address Range.....	0 to 127 (menu selectable)

Modbus Model

Consumption	50 mA max @ 24 Vdc, 80 mA max @ 24 Vac
Interface.....	MS/TP, 2-wire RS-485, RTC
Baud Rate	9600, 19200, 38400, 57600, 76800 or 115200 (menu selectable)
Address Range.....	1 to 255 (menu selectable)

Tri-Color LED (optional)

Good	Green (0 to 50 ug/m ³)
Moderate	Yellow (51 to 150 ug/m ³)
Poor	Red (151 to 1000 ug/m ³)

PM Alarm Relay (optional)

Contact Ratings.....	Form C (N.O. + N.C.), 2A @ 140 Vac, 2A @ 30 Vdc
Relay Setpoint + Hysteresis ...	Programmable via menu
Relay Time Delay.....	Programmable via menu

General

LCD Size	35mm W x 15mm H (1.4" x 0.6") alpha-numeric 2 line x 8 characters
LCD Backlight.....	Enable or disable via menu
Display Values	0 to 500 Air Quality Index or 0 to 1000 ug/m ³
Power Supply	Class 2 24 Vac/dc ±20% (non-isolated half-wave rectified)
Protection Circuitry.....	Reverse voltage protected, overvoltage protected
Operating Conditions	-10 to 60°C (14 to 140°F), 0 to 95 %RH non-condensing
Storage Conditions	-40 to 70°C (-40 to 158°F)
Wiring Connections.....	Screw terminal block (14 to 22 AWG)
Enclosure Dimensions	130 mm W x 130 mm H x 75 mm D (5.12" x 5.12" x 2.95")
Enclosure Material.....	Polycarbonate, IP65 (NEMA 4X)
Weight	408gm (14.4oz)
Country of Origin.....	Canada

Accessories

PMFRSM	Replaceable sensor module and wire harness
--------------	--

NETWORK SETUP GUIDE

The network setup guide describes the implementation of the BACnet® or Modbus protocol. It is intended to assist control system programmers who may need to add support to their systems to communicate with the device.

BACnet® and Modbus setup guide downloads are available online.



BACnet® PROTOCOL

<https://downloads.greystoneenergy.com/SG/SG-PMXXXBAC.pdf>



MODBUS PROTOCOL

<https://downloads.greystoneenergy.com/SG/SG-PMXXXMOD.pdf>