

Field Replacement of Particulate Sensor

Installation Instructions

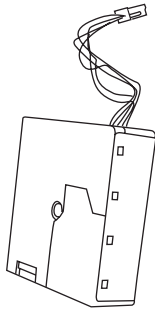

INTRODUCTION

For replacement of the sensor on the Room, Outside, & Duct Particulate Matter Transmitter.

BEFORE INSTALLATION

Read these installation instructions carefully before commissioning the Particulate Matter Sensor. Failure to follow these instructions may result in product damage. Do not use in an explosive or hazardous environment, with combustible or flammable gases, as safety or emergency stop devices or in any other application where failure of the product could result in personal injury. **Use electrostatic discharge precautions during installation and do not exceed the device ratings.**

PMRM - Room Particulate Matter Transmitter

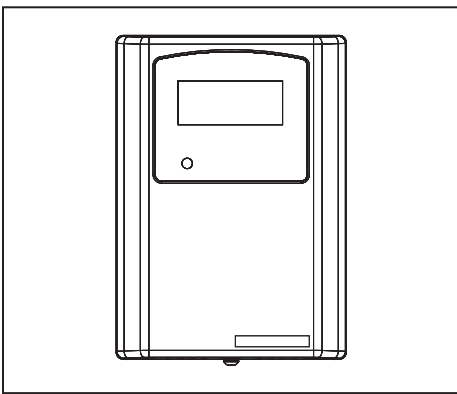

1 Ensure the power to the unit has been switched off before beginning the replacements of the sensor. A small Phillips screwdriver will be required.

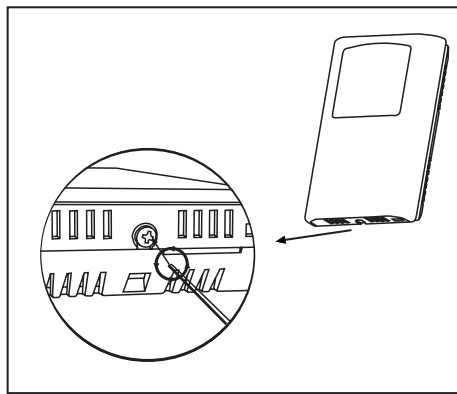

2 The cover is hooked to the base at the top edge and must be removed from the bottom edge first. Use the screwdriver to loosen the security screw. Complete removal of the screw is not required.

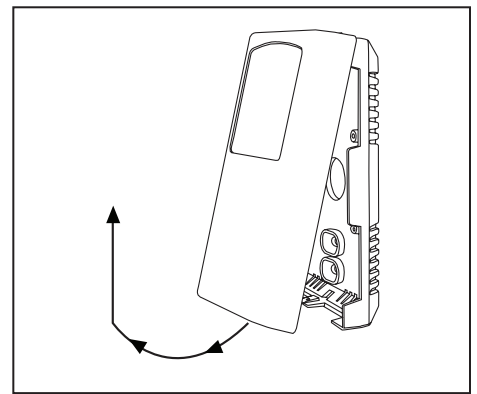

3 Use the screwdriver to pry each bottom corner if necessary. Tip the cover away from the base and set aside.

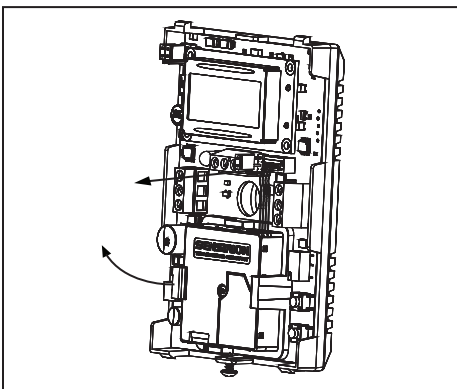

4 Unplug the sensor harness from the main board. To remove the sensor from the holding clip gently push clip away from one side of the sensor.

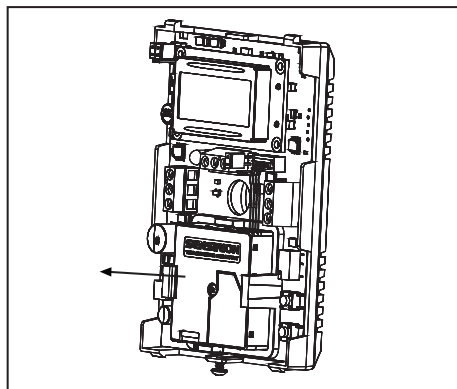

5 Lift sensor out of clip housing

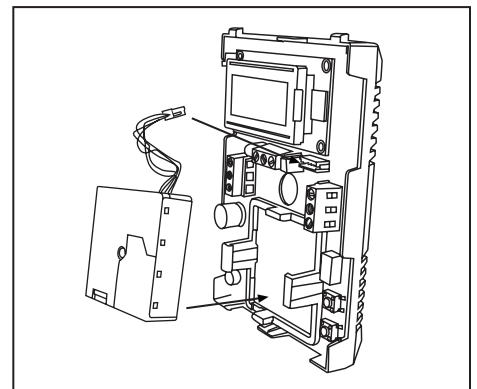

6 To install new sensor, insert one side of sensor into clip housing under top clip and push sensor down until opposite top clip secures sensor to PCB. Plug harness from sensor into connector on PCB, note the connector is polarized to prevent incorrect installation.

PMDT - Duct Particulate Matter Transmitter

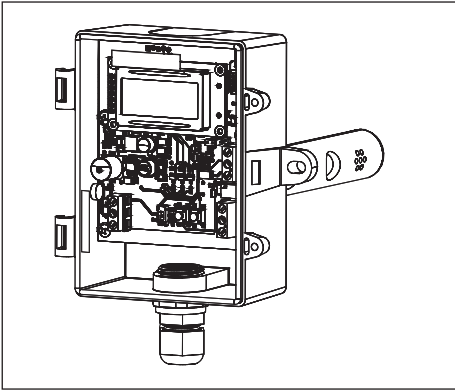

1 Ensure the power to the unit has been switched off before beginning the replacements of the sensor. A small Phillips screwdriver will be required. Open the cover.

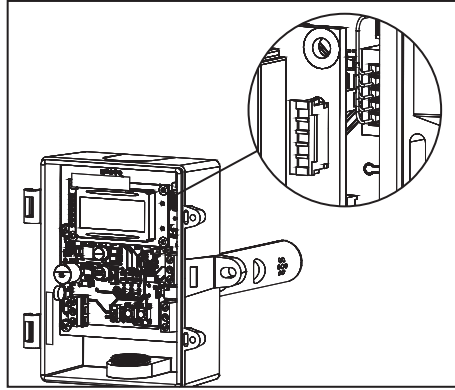

2 Unplug the wire harness from the mainboard.

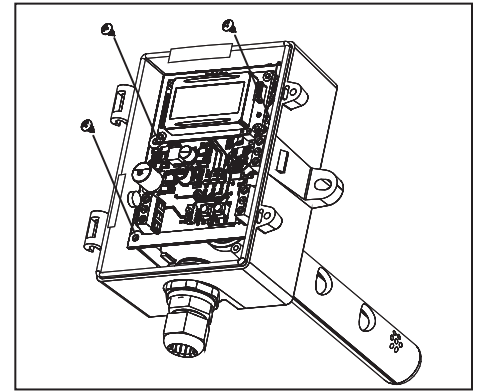

3 Remove the three PCB screws using a Phillips screwdriver.

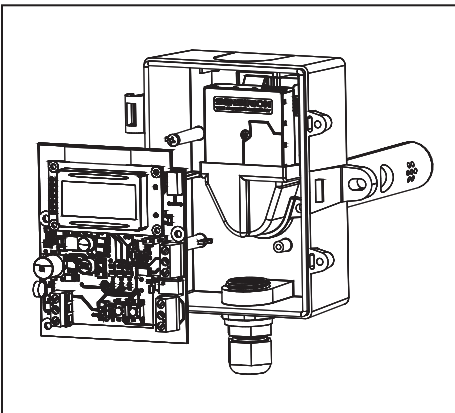

4 Carefully lift and remove the PCB main board. Set aside.

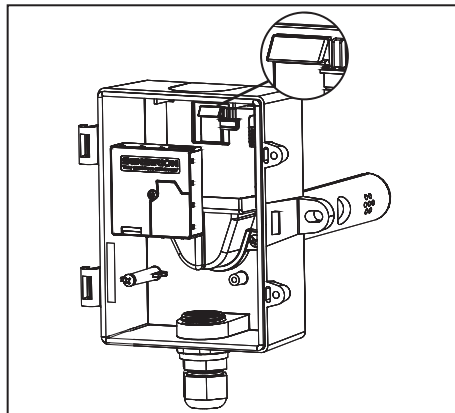

5 To remove sensor, gently push the tab, while sliding the sensor up and out of the holder.

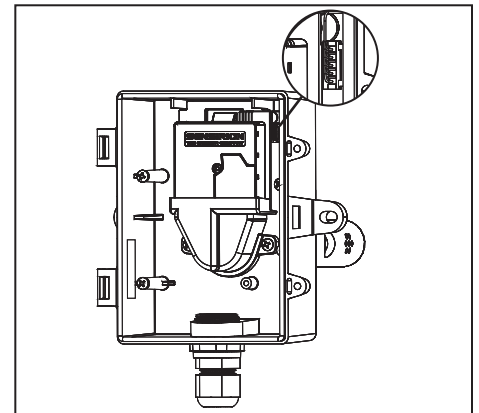

6 Insert new sensor. Plug harness from sensor into connector on PCB, note the connector is polarized to prevent incorrect installation.

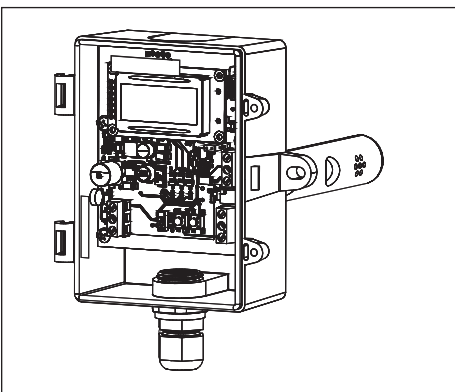

7 Place PCB board back in place. Tighten 3 security screws.

PMOS - Outside Particulate Matter Transmitter

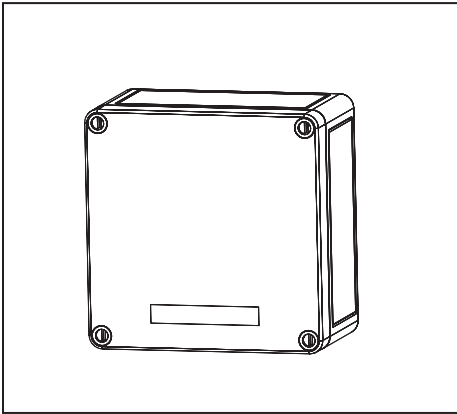

1 Ensure the power to the unit has been switched off before beginning the replacements of the sensor.

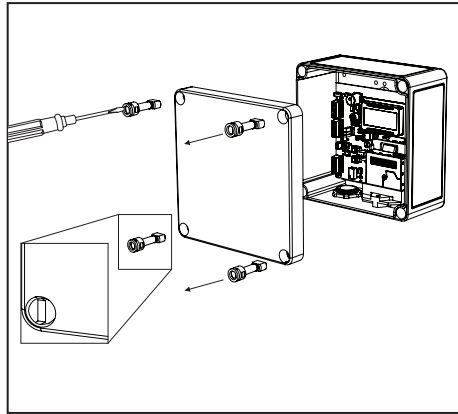

2 Remove the cover by using a standard or Phillips screwdriver to loosen the four screws. As the screws are captive type, complete removal of the screw from the cover is not required.

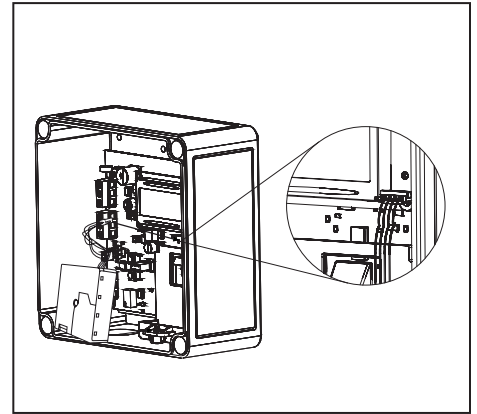

3 Unplug the sensor harness from the main board.

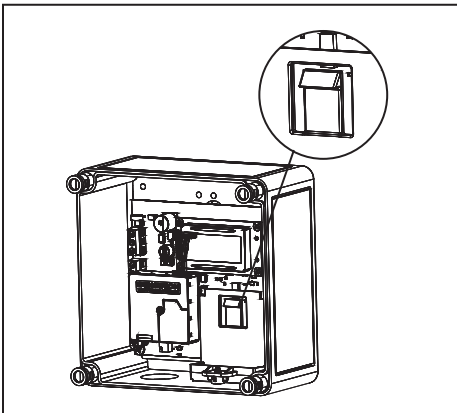

4 To remove the sensor from the holding clip gently push clip away from one side of the sensor.

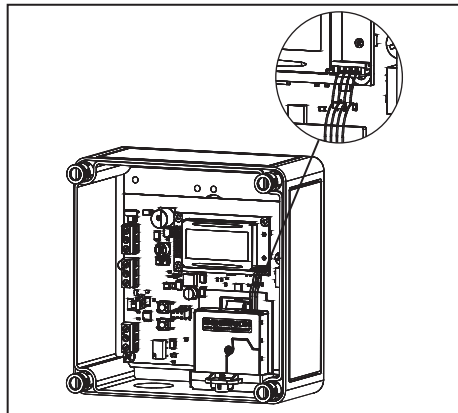

5 Insert one side of sensor into clip housing under top clip and push sensor down until opposite top clip secures sensor to PCB. Plug harness from sensor into connector on PCB, note the connector is polarized to prevent incorrect installation.

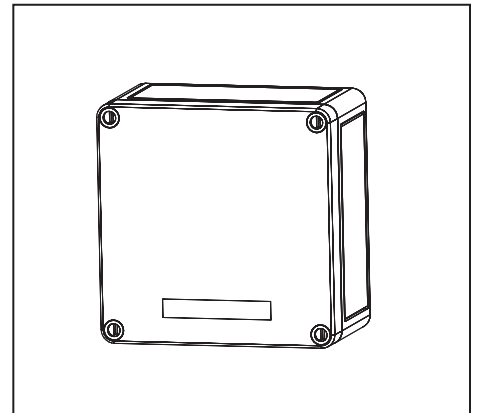

6 Place cover back in place. Tighten four screws.