

High Accuracy Gage Pressure Transmitter

Installation Instructions

Introduction

The gage pressure transmitter is designed with a single sensor that enables it to accept high pressure in several ranges up to 500 PSI, 30 Bar or 3000 kPa. All models can handle overload pressure 2X the maximum full scale range and burst pressure is 5X the maximum full scale range.

Features include field selectable pressure ranges, output signal types, output reversal and slow-dampening for the most flexible applications. The output signal is factory calibrated and temperature compensated for the highest start-up accuracy.

WARNING : Ensure that the maximum individual port pressure does not exceed the highest pressure range of the unit. For example, the highest individual port pressure on a HAWP-D-102 is 100 PSI. Exceeding this may damage the sensor and WILL give erroneous readings. See Figure 9 for ratings.

Before Installation

Read these instructions carefully before installing and commissioning the pressure transmitter. Failure to follow these instructions may result in product damage. Do not use in an explosive or hazardous environment, with combustible or flammable gases, as a safety or emergency stop device or in any other application where failure of the product could result in personal injury. Take electrostatic discharge precautions during installation and do not exceed the device ratings.

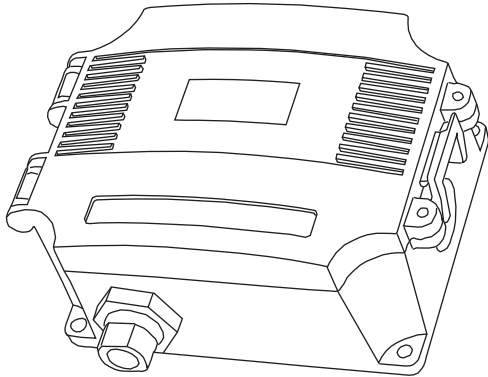

Mounting

The Pressure transmitter mounts on a vertical surface with the pressure port on the bottom using the four mounting holes on the base of the unit. The four mounting holes will facilitate a #10 size screw (not supplied). See Figure 1. Ensure there is enough space around the unit to make the pressure and electrical connections. Avoid locations with severe vibrations or excessive moisture. The enclosure has a standard opening for a conduit connector or cable gland type fitting.

The enclosure has a hinged cover with latch. Open the cover by pulling slightly on the latch on the right side of the enclosure and at the same time pulling on the cover, as illustrated in Figure 2.

A 21 mm (0.8125") hole is provided for connection of either a 1/2" conduit connector or a cable gland style connector. Insert the conduit or cable gland connector through the hole and securely fasten using a locknut as shown in Figure 3.

Two security screws are provided which can be installed to help secure the cover once settings and wiring connections are complete. See Figure 4.

Figure 1

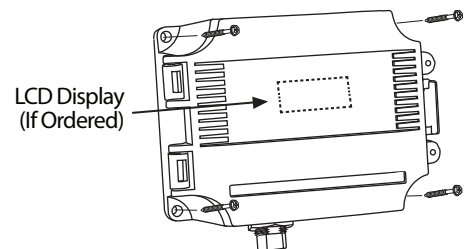

Figure 2

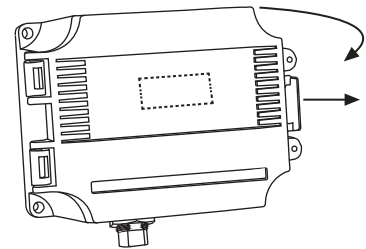

Figure 3

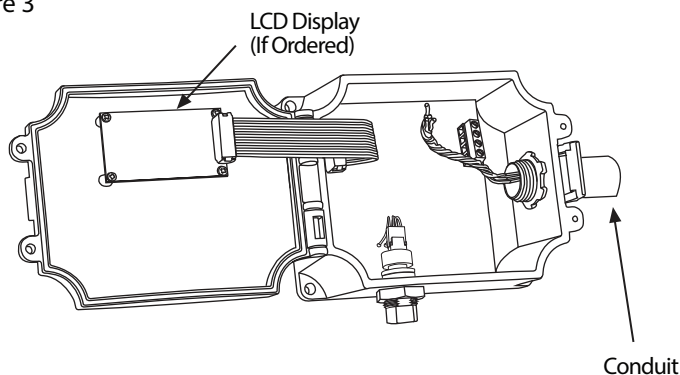
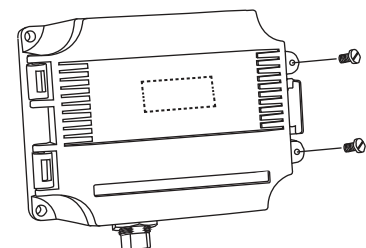

Figure 4



Plumbing

The S/S pressure port accepts a 1/8" NPT male fitting. Use appropriately rated pressure tubing and arrange it to minimize stress on the connections. Do not allow material to fall into the pressure port as contamination could damage the sensors. It is recommended to use teflon tape to prevent leaks.

Wrap 1/8" NPT male fittings with teflon tape. Screw into the port on the pressure sensor until finger tight. Using an appropriate size wrench, tighten the fitting until snug as shown in Figure 5.

Configuration

As shown on the drawing in Figure 6, several DIP switches are used to select the output signal type, the input pressure range and features that include Backlight on/off, slow damping and analog output reverse functions.

WARNING: The pressure transmitter must NOT have powered applied during set up or when making changes to the Output signal.

OUTPUT SELECTION: The pressure transmitter comes with user-selectable outputs of 4-20 mA, 0-5 Vdc and 0-10 Vdc. **It is factory configured to operate in the CURRENT (4-20 mA output) mode**, but can be changed to VOLTAGE mode by sliding the output selection switch from the position marked CURRENT to the position marked VOLTAGE as shown in Figure 7.

In VOLTAGE mode the output scale may be changed to either 0-5 or 0-10 Vdc by moving the DIP switch to the 10V or 5V position as shown in Figure 8. **The factory default is 10V.**

If CURRENT mode was selected, DIP switch position in Figure 8 is not applicable.

RANGE SELECTION: Each model of the pressure transmitter includes four pressure ranges to select from. The input pressure range is set by moving one of the 4 DIP switches to the on position as shown in Figure 9.

The factory default for every model is Range 1.

The model number is printed on a label showing the available ranges for that model is adhered to the inside of the enclosure.

FEATURES:

The factory default for all features is OFF except the Backlight if LCD is ordered. Backlight default is ON. See Figure 10.

BACKLIGHT ON: If the pressure transmitter was ordered with the LCD option, this switch can be used to turn the backlight on/off. The backlight is enabled in the ON position but can be set to OFF to reduce power consumption.

Figure 5

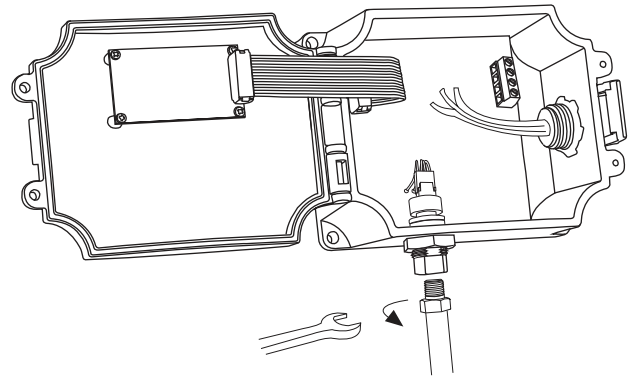

Figure 6

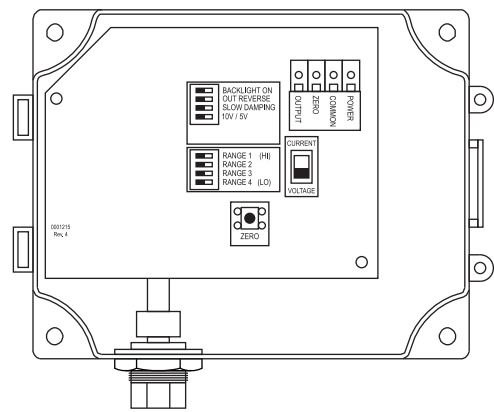

Figure 7

Output Type Selection



Factory default is CURRENT

Figure 8

Output Voltage Span Selection

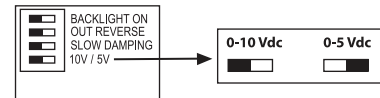

Factory Default is 0-10 Vdc

Figure 9

Pressure Range Selection

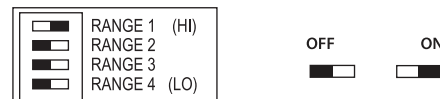

Model	Pressure Ranges (All ranges are 0 - XX)			
HAWP-G-	1	2	3	4
101	50 PSI	25 PSI	10 PSI	5 PSI
102	100 PSI	50 PSI	20 PSI	10 PSI
103	200 PSI	100 PSI	40 PSI	20 PSI
104	500 PSI	250 PSI	100 PSI	50 PSI
105	5.0 Bar	2.5 Bar	1.0 Bar	0.5 Bar
106	7.5 Bar	3.75 Bar	1.50 Bar	0.75 Bar
107	10 Bar	5 Bar	2 Bar	1 Bar
108	30 Bar	15 Bar	6 Bar	3 Bar
109	500kPa	250 kPa	100 kPa	50 kPa
110	750 kPa	375 kPa	150 kPa	75 kPa
111	1000 kPa	500 kPa	200 kPa	100 kPa
112	3000 kPa	1500 kPa	600 kPa	300 kPa

Factory default for all models is Range 1

Configuration continued

OUTPUT REVERSE: This option, when turned on reverses the output signal polarity. In reverse mode the analog output is maximum when the pressure differential is zero and decreases as pressure increases.

SLOW DAMPING: This option, when turned on provides an 8-second averaging for surge dampening (Standard is 4 seconds).

To turn any of these features on, slide the appropriate DIP switch to the ON position as shown in Figure 10.

Wiring

- Deactivate the 24 Vac/dc power supply until all connections are made to the device to prevent electrical shock or equipment damage.
- Use 14-22 AWG wiring (shielded recommended) for all connections and do not locate the device wires in the same conduit with wiring used to supply inductive loads such as motors. Make all connections in accordance with national and local codes.
- Pull at least six inches of wire into the enclosure, then complete the wiring connection according to the wire diagram for the applicable power supply and output signal type.
- Connect the plus DC or the AC voltage hot side to the POWER terminal. The supply Common is connected to the COMMON terminal. **DO NOT connect power to the OUTPUT terminal as the device will be damaged.** It has a half-wave power supply so the supply Common is the same as the signal Common. See Figure 11.
- The analog output is available on the OUTPUT terminal. Check the controller Analog Input to determine the proper connection before applying power.
- If using the Zero function, connect the Remote Zero Switch between the ZERO and COMMON terminals.

Figure 10

Factory default for all settings is Off except Backlight
LCD Backlight factory default is ON

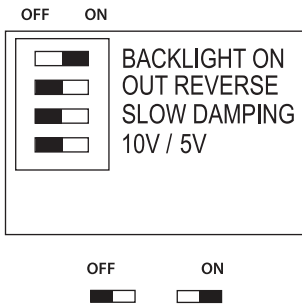
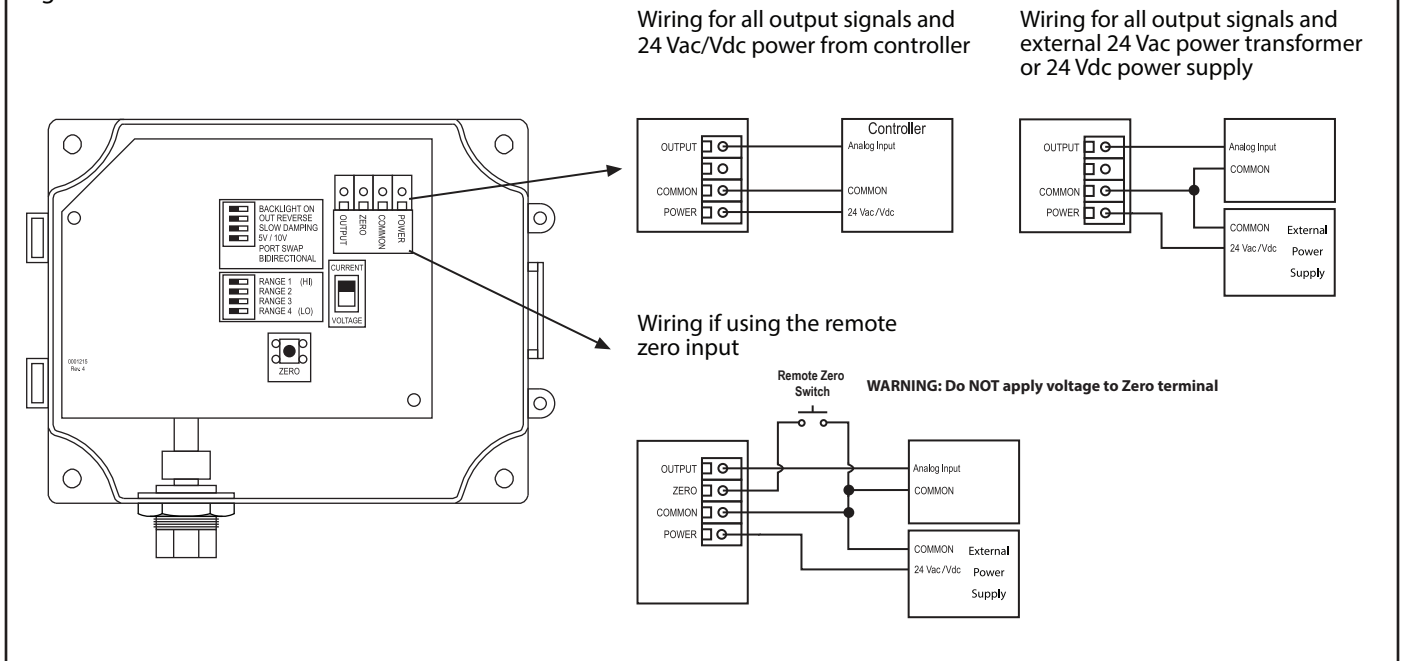

Figure 11



Operation:

For normal operation such as 0-100 PSI, the port is used to measure a positive pressure and 0 PSI = 4 mA and 100 = PSI = 20 mA

Calibration:

With the port open to the ambient pressure, press and hold the auto-zero button or provide contact closure on the ZERO terminals for at least 3 seconds. See Figure 11. Release the button or terminals and the device will calculate and store the new zero point. To protect the unit from accidental zeroing this feature is enabled only when the detected pressure is less than 5% of the full range. It is not recommended that span calibration be performed in the field unless a high quality calibrator is available.

