

High Accuracy Flying Lead Temperature Transmitter

Installation Instructions

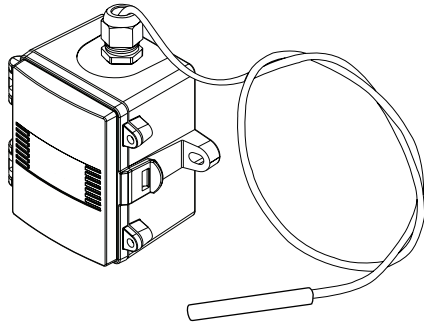

INTRODUCTION

The high accuracy single point flying lead temperature transmitter utilizes a precision sensor that is encapsulated in a 50 mm (2") long x 6 mm (0.236") diameter OD, 304 series stainless steel probe and is provided with 3.05 m (10') of plenum rated FT-6 cable. All probes provide excellent heat transfer, fast response and resistance to moisture penetration. A compact ABS enclosure with a hinged and gasketed cover is provided for ease of installation.

BEFORE INSTALLATION

Read these instructions carefully before installing and commissioning the temperature sensor. Failure to follow these instructions may result in product damage. Do not use in an explosive or hazardous environment, with combustible or flammable gases, as a safety or emergency stop device or in any other application where failure of the product could result in personal injury. **Do not exceed the device ratings.**

MOUNTING (DUCT)

The flying lead sensor can be used in several different types of applications where single point temperature monitoring is required.

Listed below are some typical applications

The flying lead sensor can be installed directly into any air duct. Select a suitable installation area in the middle of the duct. To achieve the best reading, do not place in an area where air stratification may be present. Avoid areas where the sensor is exposed to vibrations or rapid temperature changes.

Once a suitable spot is selected, drill a 3/8" hole in the top of the duct and slide the probe through, mount a length of flexible duct hanger from top to bottom of the duct. Mount the probe to the duct hanger using a tube clamp or wire tie. See Figure 1.

The flying lead could also be used to measure pipe temperature. Select a suitable spot along the pipe, remove a small section of insulation if present and set aside. It is recommended that thermal compound be used to improve heat transfer. Spread a liberal amount on the pipe. Lay probe in thermal compound and secure sensor to pipe using a worm gear clamp (not included).

For added protection it is recommended to wrap the probe cable around the pipe 1 to 2 times. Re-install insulation if present, allowing sensor cable to protrude. See Figure 2.

The enclosure has a hinged cover with a latch. Open the cover by pulling slightly on the latch on the right side of the enclosure. At the same time pulling on the cover, as shown in Figure 3.

A 1/2" NPT threaded connection hole is provided in the bottom of the enclosure. Screw the EMT connector or cable gland connector in until tight. See Figure 4. It is recommended that weatherproof conduit or cable gland fittings be used. The E style enclosure includes a 1/2" NPT to M16 thread adapter and cable gland fitting.

Make wiring connections as per the "Wiring" illustrations on Page 2.

Swing door closed until securely latched. For added security, 2 screws are provided that may be installed in the integrated screw tabs. See Figure 5.

Figure 1

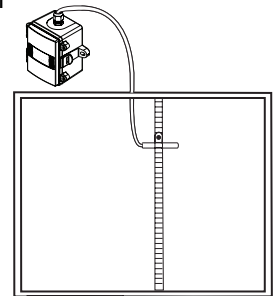

Figure 2

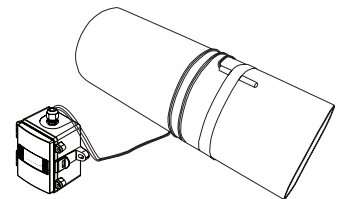

Figure 3

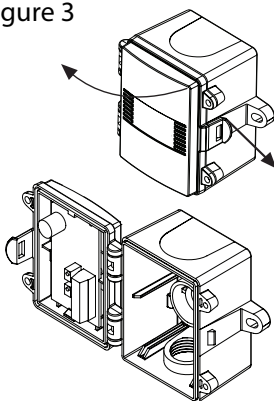

Figure 4

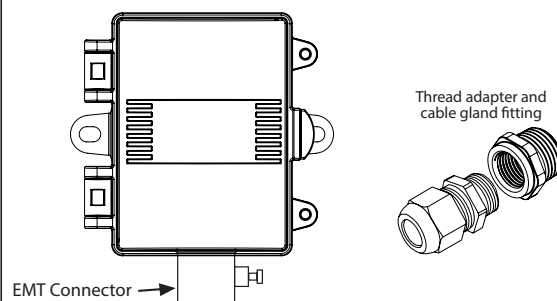
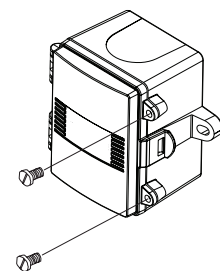
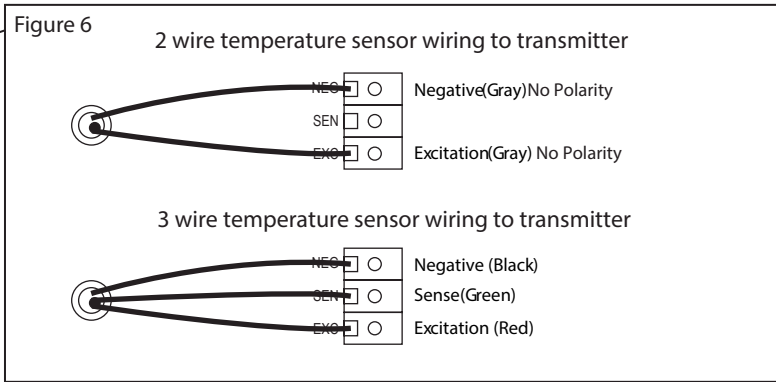
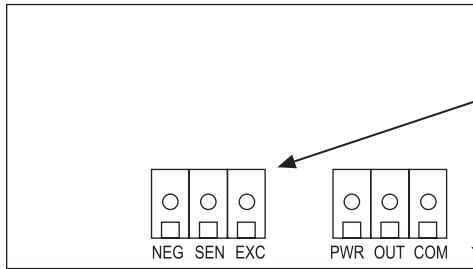

Figure 5



WIRING

- Deactivate the 24 Vac/dc power supply until all connections are made to the device to prevent equipment damage.
- Use 14-22 AWG shielded wiring for all connections and do not locate the device wires in the same conduit with wiring used to supply inductive loads such as motors. Make all connections in accordance with national and local codes.
- The temperature transmitter comes with the temperature sensor pre-wired to the transmitter board. If removal is required for installation then it may be re-wired as shown in Figure 6.
- Pull at least six inches of control wire into the enclosure, then complete the wiring connection according to the wire diagram for the applicable power supply and output signal type as shown in Figure 7.
- Connect the DC positive or the AC voltage hot side to the PWR terminal. For voltage output or AC power, the supply Common is connected to the COM terminal. The device is reverse voltage protected and will not operate if connected backwards. It has a half-wave power supply so the supply Common is the same as the signal Common. See Figure 7.
- The analog output is available on the OUT terminal. Check the controller Analog Input to determine the proper connection before applying power as shown in Figure 7.
- Once all connections are made and checked, power can be applied.



SPECIFICATIONS

Sensor Type	1000Ω Platinum, IEC 751, 385 Alpha, thin film
Sensor Accuracy	RTD Class A: ±0.15°C (±0.27°F) @ 0°C (32°F) RTD 1/3 DIN: ±0.1°C (±0.18°F) @ 0°C (32°F) RTD 1/10 DIN: ±0.03°C (±0.054°F) @ 0°C (32°F)
Probe Sensing Range	-40 to 60°C (-40 to 140°F)
Wire Material	FT-6 rated plenum cable, 22 AWG
Wire Length	3.05 m (10')
Probe Material	304 series stainless steel
Output Signal	4-20 mA current loop, 0-5 Vdc, or 0-10 Vdc (factory configured)
Transmitter Accuracy	±0.1% of span, including linearity
Output Drive @ 24 Vdc:	Current: 600Ω maximum Voltage: 10 KΩ minimum
Power Supply:	0-5 Vdc: 10-35 Vdc or 10-28 Vac 0-10 Vdc: 15-35 Vdc or 15-28 Vac 4-20 mA: 15-35 Vdc (Loop-powered) or 22-28 Vac
Current Consumption:	Current: 20 mA Voltage: 5 mA
Maximum Current (Voltage)	5 mA nominal
Maximum Output (Voltage)	Limited to <5.5 Vdc for 0-5 Vdc, <10.5 for 0-10 Vdc
Input Voltage Effect	Negligible over specified operating range
Protection Circuitry	Reverse voltage protected and output limited
Ambient Operating Range	-40 to 50°C (-40 to 122°F), 0 to 95 %RH non-condensing
Enclosure	A: ABS, UL94-V0, IP65 (NEMA 4X) E: Same as A, with thread adapter (1/2" NPT to M16), and cable gland fitting
Termination	Screw terminal block (14 to 22 AWG)
Approvals	CE
Country of Origin	Canada

*This product is factory calibrated and any field adjustment will void the warranty.

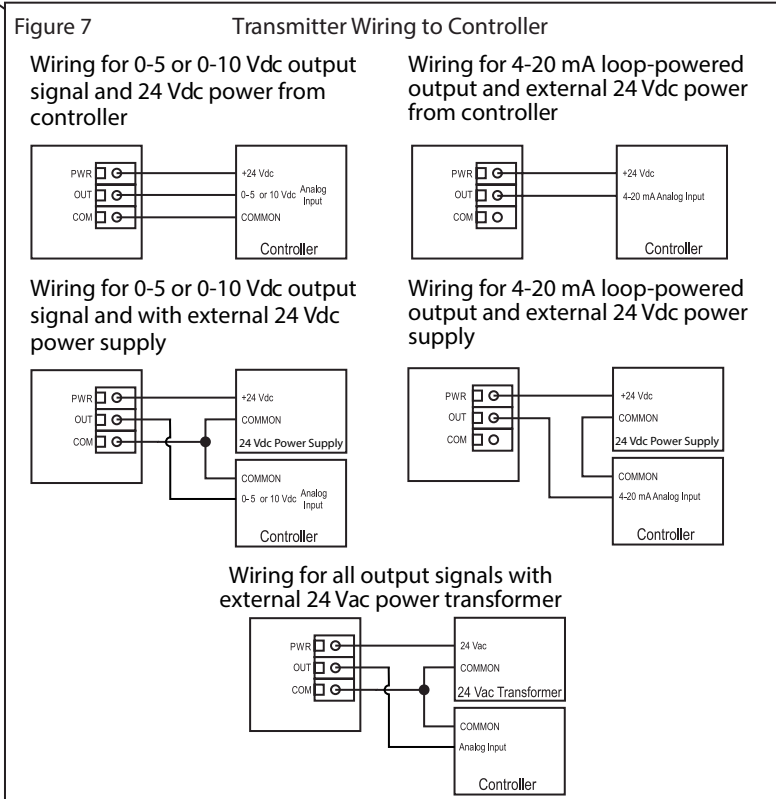

DIMENSIONS

