

High Accuracy Room Temperature Sensor

Installation Instructions

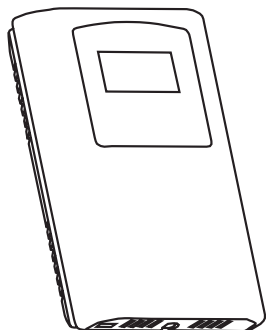

INTRODUCTION

The continental series is an attractive, low profile enclosure that incorporates a precision temperature sensor used to monitor room temperatures. Additional options are available that include set-point adjustment, manual override, fan speed, handset communication port, and an LCD.

BEFORE INSTALLATION

Read these instructions carefully before installing and commissioning the device. Failure to follow these instructions may result in product damage. Do not use in an explosive or hazardous environment, with combustible or flammable gases, as a safety or emergency stop device or in any other application where failure of the product could result in personal injury. Take electrostatic discharge precautions during installation. **Do not exceed the device ratings.**

MOUNTING

The temperature sensor mounts directly on a wall or onto an electrical wall box. For the most accurate results, the unit should be mounted on an inside wall to a wall box five feet from the floor. Do not mount the sensor near doors, opening windows, supply air diffusers, or other known air disturbances. Avoid areas where the sensor is exposed to vibrations or rapid temperature changes.

The cover is hooked to the base at the top edge and must be removed from the bottom edge first. Use a small Phillips screwdriver to loosen the security screw as shown in Figure 1. (Complete removal is not required). Use a screw driver to carefully pry each bottom corner if necessary. Tip the cover away from the base and sit it aside as shown in Figure 2.

SENSOR ONLY

Feed at least 6 inches of wire through the wall and out of the junction box and feed connection wires through the center hole on the backplate. Secure the backplate to the wall or electrical box with suitable screws (not supplied) as shown in Figure 3. The mounting holes in the backplate allow for up, down, and side to side movement to compensate for unlevel electrical box installation.

Retrieve the sensor with clip. Turn the clip over and remove the backing from the clip to expose the adhesive back. Stick the clip on a smooth surface of the backplate. See Figure 4.

Make wire connections as per the Wiring Illustrations on Page 2.

Re-install the decorative cover by placing the top of the cover into the cover holder on the top of the backplate and snapping the bottom into place as shown in Figure 7. Tighten security screw with a screwdriver.

Figure 1

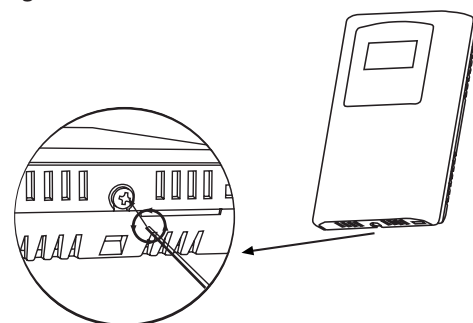

Figure 2

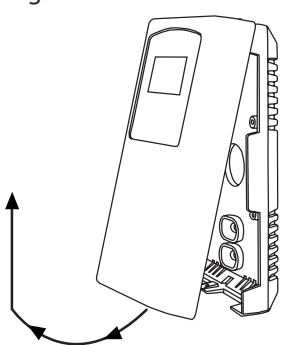

Figure 3

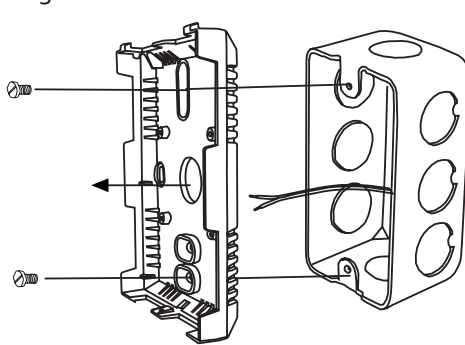

Figure 4

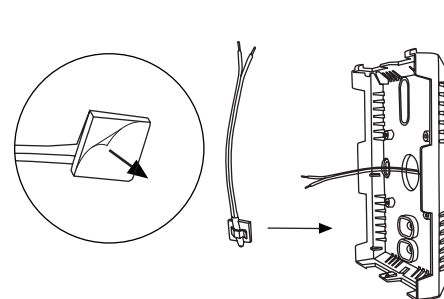

Figure 4

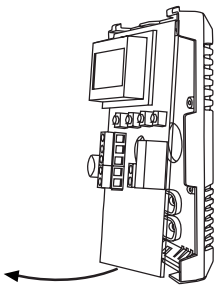

Figure 5

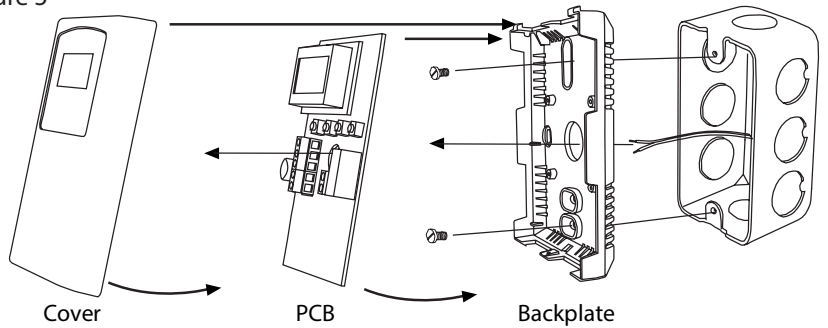
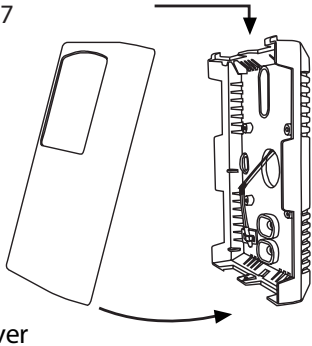

Figure 7



WITH PCB

The PCB must be removed from the base to access the mounting holes. Follow usual anti-static procedures when handling the PCB and be careful not to touch the sensors. The PCB is removed by pressing the enclosure base to unsnap the latch near the bottom edge, then the PCB can be lifted out of the base as shown in Figure 4.

Set the PCB aside until the base is mounted on the wall. For added protection, place the PCB in the supplied anti-static bag.

Mount the base by screwing it to an electrical box or directly to the

wall as shown in Figure 5.

After the base is screwed to an electrical box or the wall using the appropriate holes, remove the PCB from the anti-static bag, feed connection wires through center hole and place the top of the PCB into the PCB holders on the backplate and snap the bottom of the PCB into place as shown in Figure 5.

Make wire connections as per the Wiring Illustrations on pages 2 and 3. Re-install decorative cover by placing the top of the cover into the cover holder on the top of the backplate and snapping the bottom into place as shown in Figure 7. Tighten security screw with a screwdriver.

WIRING

- If LCD is present, deactivate the 24 Vac/dc power supply until all connections are made to the device to prevent electrical shock or equipment damage. Follow proper electrostatic discharge (ESD) handling procedures when installing the device or equipment damage may occur.
- Use 22 AWG shielded wiring for all connections and do not locate the device wires in the same conduit with wiring used to supply inductive loads such as motors. Connect the cable shield to ground at the controller only. Make all connections in accordance with national and local codes.
- Connector layout is shown in Figure 9. The diagram shown includes all options, if an option is not ordered, the connector will not be present.

Figure 8

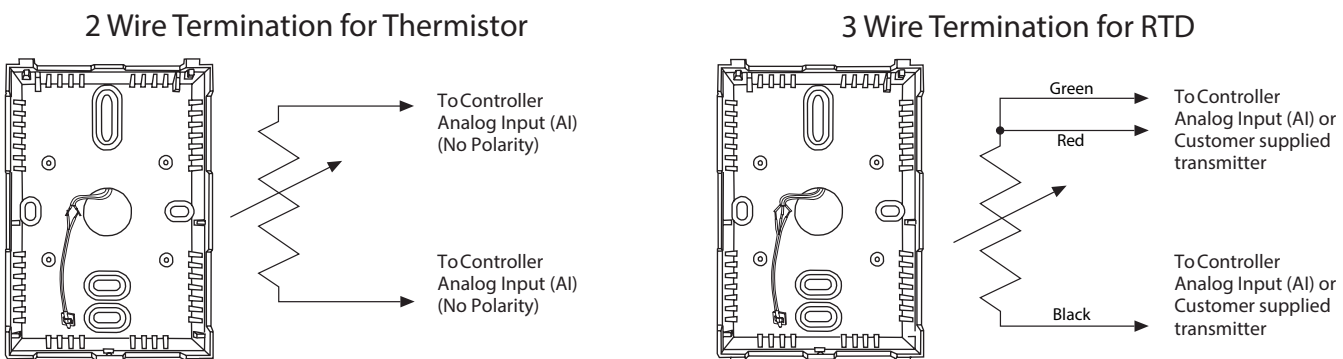

Figure 9

Wiring for PCB

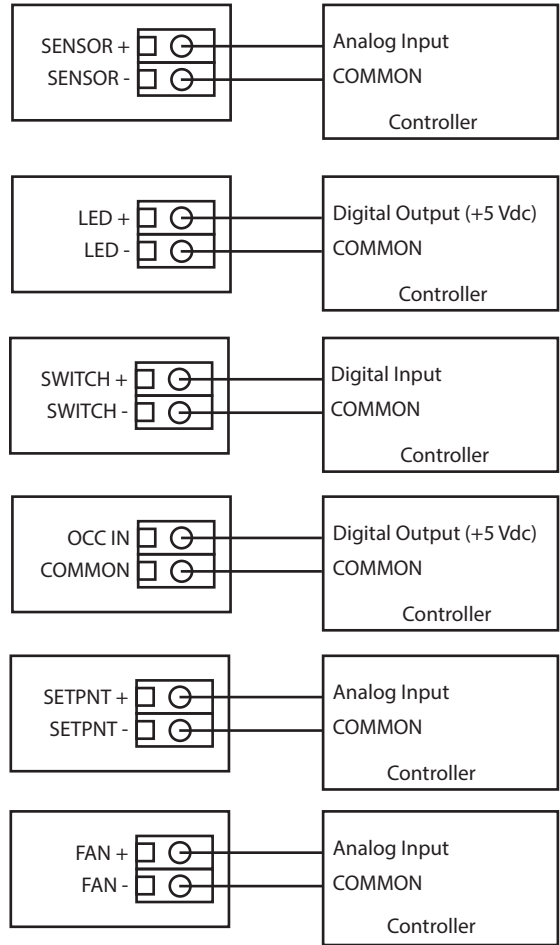
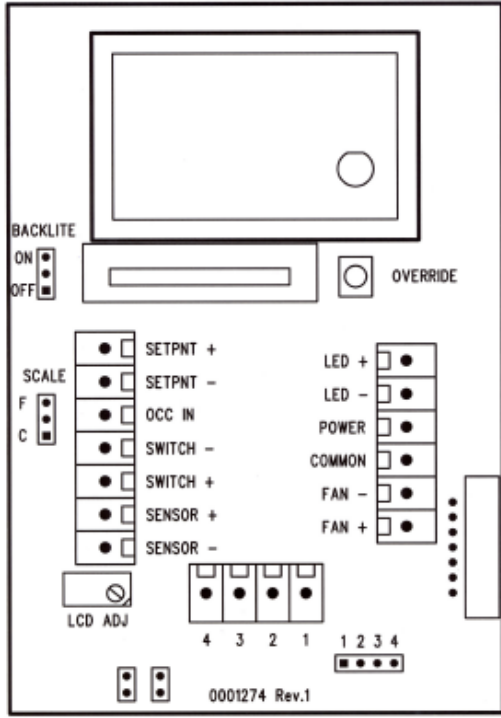
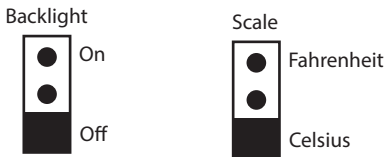

Figure 10



If the unit has the LCD option then the scale can be set to either °C or °F via the Scale jumper. See Figure 10. If the unit is also equipped with the backlight option it can be enabled or disabled via the Backlight jumper. The LCD display can be calibrated by adjusting the LCD ADJ pot.

MANUAL OVERRIDE/OCC IN

The optional override switch output is a dry-contact and is available on the SWITCH + and SWITCH - terminals. It is typically connected

to a low-voltage digital input on the controller to indicate room occupancy or override when the button is activated.

If the override switch is ordered with the optional LCD, also included is the OCC IN. The OCC IN terminal is a digital input that controls the OCC segment on the LCD to indicate an occupied condition. It can be connected to a 0-5V digital signal or a dry contact signal. This is usually an active low input signal and requires that the OCC IN terminal be shorted to COMMON to activate the input.

LED

The LED is typically used as indication as when manual override has been selected. It is available on the LED+ and LED- terminals and requires 5 Vdc to power. The LED option is not available when LCD installed

FAN SPEED SWITCH

The 5 position speed fan speed has a resistance output signal on the FAN + and FAN - terminals and has different resistances for each position 5 positions (Auto, Off, Low, Mid, High).

EXTERNAL JACK

The external jack is internally connected to a 4-pin terminal block labeled 1, 2, 3, 4 and accepts a 4 pin molex connector for remote communication with the controller. The HHTA-XXX adapter converts the 4-pin Moles to a 4 pin phone jack connection.

SPECIFICATIONS

GENERAL

Sensing Element.....	Various thermistors and RTD's
Sensor Accuracy.....	RTD Class A: $\pm 0.15^{\circ}\text{C}$ ($\pm 0.27^{\circ}\text{F}$) @ 0°C (32°F) RTD 1/3 DIN: $\pm 0.1^{\circ}\text{C}$ ($\pm 0.18^{\circ}\text{F}$) @ 0°C (32°F) RTD 1/10 DIN: $\pm 0.03^{\circ}\text{C}$ ($\pm 0.054^{\circ}\text{F}$) @ 0°C (32°F) NTC Thermistor Type 39: $\pm 0.05^{\circ}\text{C}$ ($\pm 0.09^{\circ}\text{F}$), 0 to 70°C (32 to 158°F) NTC Thermistor Type 55: $\pm 0.03^{\circ}\text{C}$ ($\pm 0.054^{\circ}\text{F}$), 0 to 70°C (32 to 158°F) NTC Thermistor Type 40/46: $\pm 0.1^{\circ}\text{C}$ ($\pm 0.18^{\circ}\text{F}$), 0 to 70°C (32 to 158°F)
Operating Conditions.....	0 to 50°C (32 to 122°F), 0 to 95 %RH non-condensing
Wiring Connections.....	Screw terminal block (14 to 22 AWG) Sensor only: Pigtail, 2 or 3 wire
Enclosure.....	White ABS, IP30 (NEMA 1) 84mm W x 119mm H x 29mm D (3.3" x 4.7" x 1.15")
Country of Origin.....	Canada

VERRIDE SWITCH

Switch Type.....	Front panel, momentary push-button, N.O., SPST, 50 mA @ 12 Vdc
------------------	---

FAN SPEED SWITCH

Range.....	Auto, Off, Low, Medium, High
Signal.....	Resistance: 2K, 4K, 6K, 8K, and 10K Ω standard (custom ranges available)

SET-POINT SLIDE POT

Range.....	Front panel pot as resistive output, 20 to 20K Ω
Custom Spans Available....	1K, 2K, 5K, 10K, or 20K Ω

OCCUPIED INPUT

Signal Type.....	Digital input, 0-5 Vdc, active low
Action.....	Causes "OCC" segment to light on LCD

LED INPUT

Signal Type.....	Active high, low, or 2 wire, 5 V current limit standard
LED Colors.....	Red, Green, or Yellow
Power Supply.....	5 Vdc standard, 10 Vdc or 24 Vdc optional

LCD DISPLAY

Power Supply.....	12-24 Vdc / 24 Vac $\pm 10\%$
Consumption @ 24 Vdc.....	13 mA max (no backlight) 23 mA max (with backlight)
Protection Circuitry.....	Reverse voltage protected
Range.....	$0.0\text{-}35.0^{\circ}\text{C}$ or $32.0\text{-}95.0^{\circ}\text{F}$ jumper selectable
Resolution.....	$0.1^{\circ}\text{C}/^{\circ}\text{F}$
Display Size.....	38.1mm W x 16.5mm H (1.5" x 0.65")
Digit Height.....	11.43mm (0.45")
Symbols.....	$^{\circ}\text{C}$, $^{\circ}\text{F}$, OCC
Backlight.....	Enable or disable via jumper

NOTE: The sensor accuracies listed in the specifications section apply to the sensing element only prior to product assembly and may not be reflected in the complete assembly.

Due to the measurement uncertainty, it is possible, that the true resistance value of the single delivered sensor at 0°C can be out of the defined tolerance class. Profiling each assembly to take into consideration lead wire and the attachment method should be completed.

DIMENSIONS

