

# High Accuracy Outside Air Temperature Sensor

## Installation Instructions

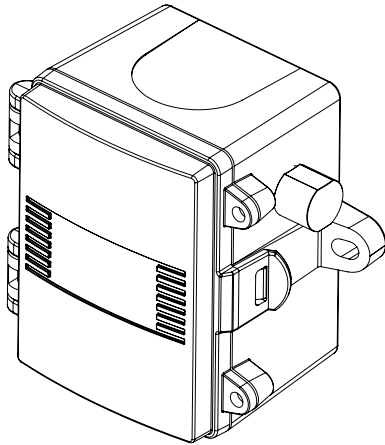

### INTRODUCTION

The high accuracy single point outside air temperature sensor utilizes a precision sensor. All probes are constructed to provide excellent heat transfer, fast response and are potted to resist moisture penetration. A sun and wind shield is integrated into a weatherproof compact polycarbonate enclosure with a hinged and gasketed cover for ease of installation.

### BEFORE INSTALLATION

Read these instructions carefully before installing and commissioning the temperature sensor. Failure to follow these instructions may result in product damage. Do not use in an explosive or hazardous environment, with combustible or flammable gases, as a safety or emergency stop device or in any other application where failure of the product could result in personal injury. **Do not exceed the device ratings.**

### MOUNTING

Select a suitable mounting spot on an exterior wall where the sensor is best protected from direct exposure to sunlight, wind, etc. preferably on a north facing wall. Do not mount the sensor near opening windows, supply/exhaust air louvres or other known air disturbances. Avoid areas where the sensor is exposed to vibrations or rapid temperature changes.

The sensor provides a connection hole for 22.7 mm (0.895") conduit on the back side of enclosure. Run a length of conduit through exterior wall and seal. Use 18-22 AWG shielded wiring for all connections and do not locate the device wires in the same conduit with wiring used to supply inductive loads such as motors. Make all connections in accordance with national and local codes.

The sensor installs directly on an exterior wall using the four integrated mounting holes provided on the enclosure. Select the best mounting technique based on the exterior wall material. The two mounting holes are suitable for a #10 size screw (not supplied). The sensor hub must be pointing down. See Figure 1.

The enclosure has a hinged cover with a latch. Open the cover by pulling slightly on the latch on the right side of the enclosure. At the same time pulling on the cover, as illustrated in Figure 2.

A 1/2" NPT threaded connection hole is provided in the bottom of the enclosure. Screw the EMT connector or cable gland connector in until tight. See Figure 3. It is recommended that weatherproof conduit or cable gland fittings be used. An optional 1/2" NPT to M16 thread adapter and cable gland fitting is available.

Make wiring connections as per the "wiring" illustrations on Page 2.

Swing door closed until securely latched. For added security, two screws are provided that may be installed in the integrated screw tabs. See Figure 4.

Figure 1

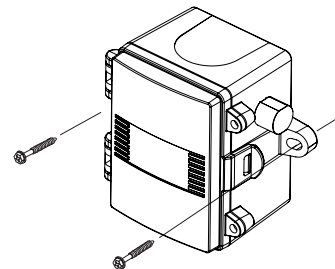

Figure 2

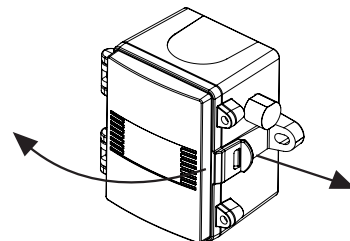

Figure 3

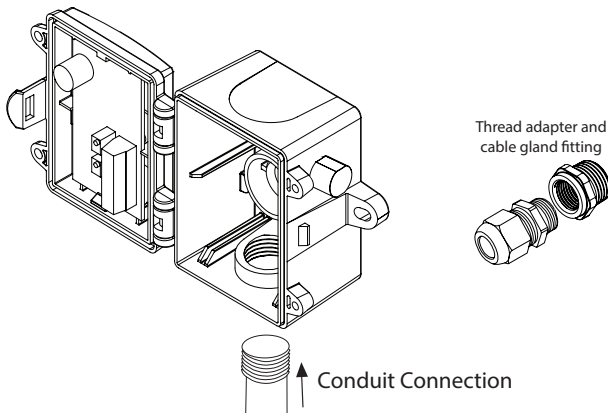
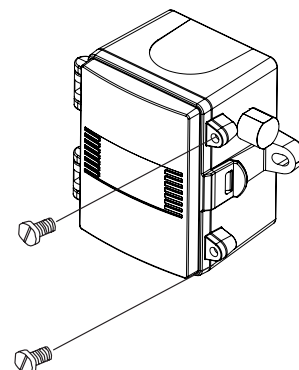
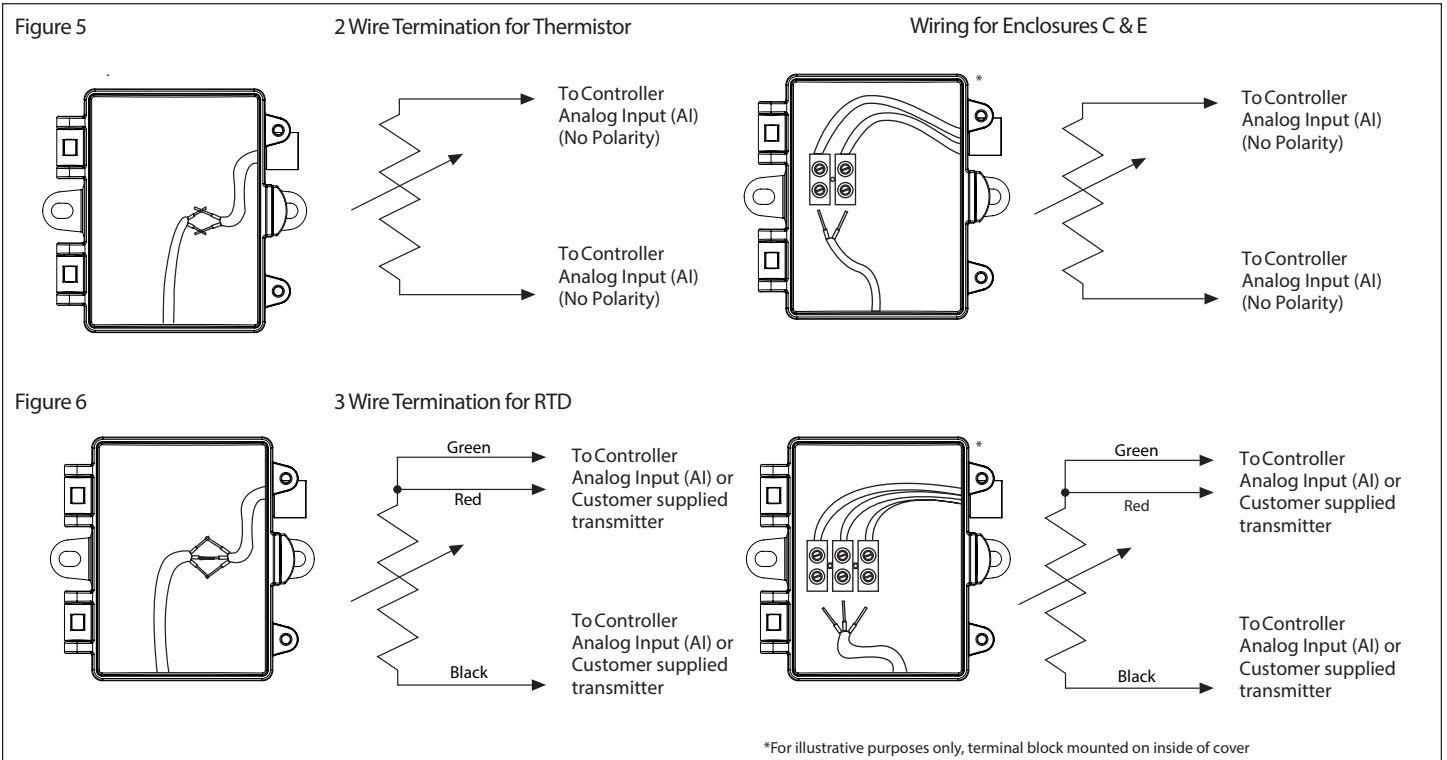

Figure 4



## WIRING

- Use 18 - 24 AWG shielded wiring for all connections. Do not locate the device wires in the same conduit with wiring used to supply inductive loads such as motors. Make all connections in accordance with national and local codes.
- Pull at least six inches of wire into the enclosure, then complete the wiring connection according to the wiring diagrams below. All connections should be made using either butt-splices or soldering. The use of wire nuts is not recommended.
- Thermistors are a 2 wire hook up and are not polarity sensitive. See Figure 5.
- RTD's are a 3 wire hook up. Figure 6.



## TYPICAL WIRE RESISTANCE VALUES

When using low resistance sensors, long wire runs can add significant error to the readings. Use the following chart to determine errors due to wire resistance or consider using a 1000 ohm sensor or a transmitter for better accuracy. Locate the type of wire being used. Multiply the total length of the wire (distance from the controller to the sensor and back) by the number found in the chart below for total resistance.

GAUGE WIRE TYPE	18 AWG	22 AWG	24 AWG
STRANDED (OHMS/FOOT)	5.85 mΩ	14.75 mΩ	23.29 mΩ
SOLID (OHMS/FOOT)	6.4 mΩ	15.85 mΩ	25.72 mΩ

**NOTE:** The sensor accuracies listed in the specifications section apply to the sensing element only prior to product assembly and may not be reflected in the complete assembly.

Due to the measurement uncertainty, it is possible, that the true resistance value of the single delivered sensor at 0°C can be out of the defined tolerance class. Profiling each assembly to take into consideration lead wire and the attachment method should be completed.

## DIMENSIONS

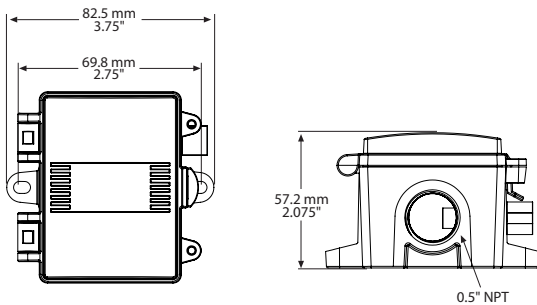

## SPECIFICATIONS

Sensor Type:..... Various thermistors or RTD

Sensor Accuracy:..... **RTD Class A:** ±0.15°C (±0.27°F) @ 0°C (32°F)  
**RTD 1/3 DIN:** ±0.1°C (±0.18°F) @ 0°C (32°F)  
**RTD 1/10 DIN:** ±0.03°C (±0.054°F) @ 0°C (32°F)  
**NTC Thermistor Type 39:** ±0.05°C (±0.09°F), 0 to 70°C (32 to 158°F)  
**NTC Thermistor Type 55:** ±0.03°C (±0.054°F), 0 to 70°C (32 to 158°F)  
**NTC Thermistor Type 40/46:** ±0.1°C (±0.18°F), 0 to 70°C (32 to 158°F)

Probe Sensing Range:..... -40 to 50°C (-40 to 122°F)

Probe Material:..... Machined Aluminum

Ambient Operating Range:..... -40 to 50°C (-40 to 122°F)

Wire Material:..... **RTD:** FT-4, 22 AWG, 3 Wire  
**Thermistor:** PVC insulated, parallel bonded, 22 AWG, 2 Wire

Enclosure:..... **A:** Polycarbonate, UL94-V0, IP65 (NEMA4X)  
**C:** Same as A, with terminal block  
**E:** Same as C, with thread adapter (1/2" NPT to M16) and cable gland fitting

Termination: ..... **A:** Pigtail, 2 or 3 wire  
**C & E:** Terminal block, 2 or 3 wire

Country of Origin:..... Canada