

High Accuracy Immersion Temperature Sensor

HATSCN

Installation Instructions

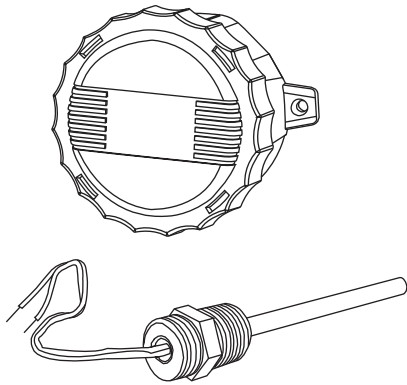

Introduction

The high accuracy single point immersion temperature sensor utilizes a precision sensor encapsulated in a 6.35 mm (0.25") OD, 304 series stainless steel probe and is available in various lengths. All probes provide excellent heat transfer, fast response and resistance to moisture penetration. A round ABS enclosure with a twist off cover is provided for ease of installation.

Before Installation

Read these instructions carefully before installing and commissioning the temperature sensor. Failure to follow these instructions may result in product damage. Do not use in an explosive or hazardous environment, with combustible or flammable gases, as a safety or emergency stop device or in any other application where failure of the product could result in personal injury. **Take electrostatic discharge precautions during installation and do not exceed the device ratings.**

Mounting

The temperature sensor must be installed into a thermowell. Failure to use a thermowell will create leaks and could damage the sensor. The temperature sensor is provided in two pieces, probe and enclosure, which allows for easier installation. The temperature has 1/2" NPT thread for mounting to the thermowell. Install the thermowell as recommended in **Figure 1**. For complete thermowell installation instructions, please refer to installation instructions provided with the thermowell.

It is recommended to use heat conductive compound. Prior to installing the sensor inject a liberal amount into the thermowell and/or on the tip of the sensor. Slide the probe into thermowell until the 1/2" NPT fitting makes contact with the thermowell. Tighten slightly by hand by turning clockwise. See **Figure 2**.

Using a 7/8" (23 mm) wrench, tighten the fitting into the thermowell until snug. To protect against overtightening and damaging the probe, the assembly is designed to allow the probe to slide inside the fitting. See **Figure 3**.

Install the enclosure by removing the cover. To remove cover grasp firmly and twist approximately a quarter turn counter-clockwise. See **Figure 4**. A lanyard is attached between the cover and the box to allow the cover to hang during wiring and set up. Insert the cable/connector through the 21 mm (13/16") hole in the back of the enclosure, mount on the probe fitting and secure with the included lock nut. See **Figure 5**.

A 21 mm (13/16") hole is provided for connection of either a 12.77mm (0.5") EMT connector or a cable gland style connector as shown in **Figure 3**. Insert the EMT or cable gland connector through the hole and securely fasten using a locknut. See **Figure 6**. **Proper EMT/Cable Gland connectors and caulk/teflon tape must be used in order to maintain IP and/or NEMA rating. Drilling of enclosure will violate the IP and/or NEMA rating.**

Make wire connections as per the "Wiring" illustrations on Page 2.

After wiring, secure the connector on place on the provided mounting studs, by pushing it in place. See **Figure 6**. Re-install cover and tighten by twisting clockwise.

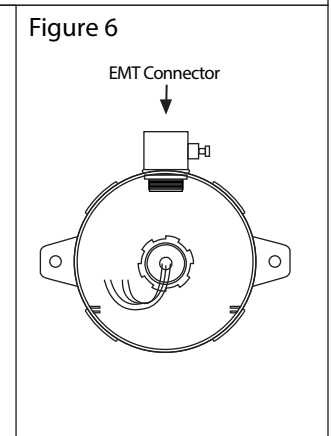
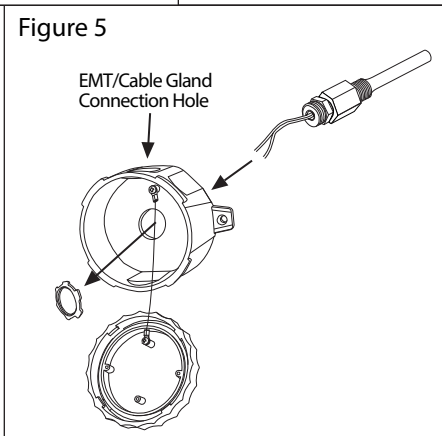
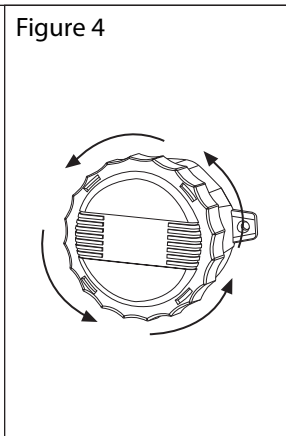
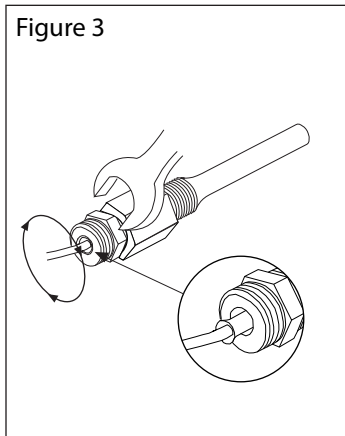
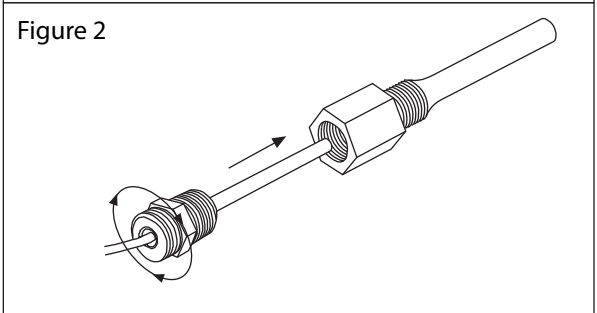
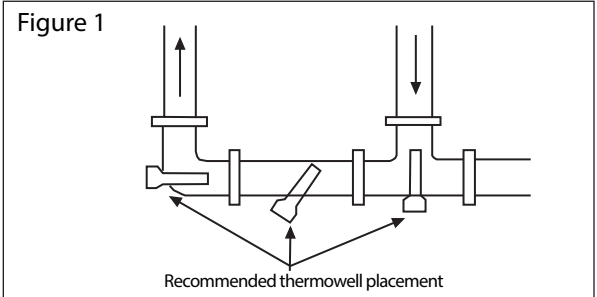

Wiring

- Use 18-24 AWG shielded wiring for all connections. **Do not locate the device wires in the same conduit with wiring used to supply inductive loads such as motors.** Make all connections in accordance with national and local codes.
- Pull at least six inches of wire into the enclosure, then complete the wiring connection according to the wiring diagrams below.
- All thermistors and most RTD's are a 2 wire hook up and are not polarity sensitive. See **Figure 5**.
- For RTD's that are 3 wire connection see **Figure 6**.

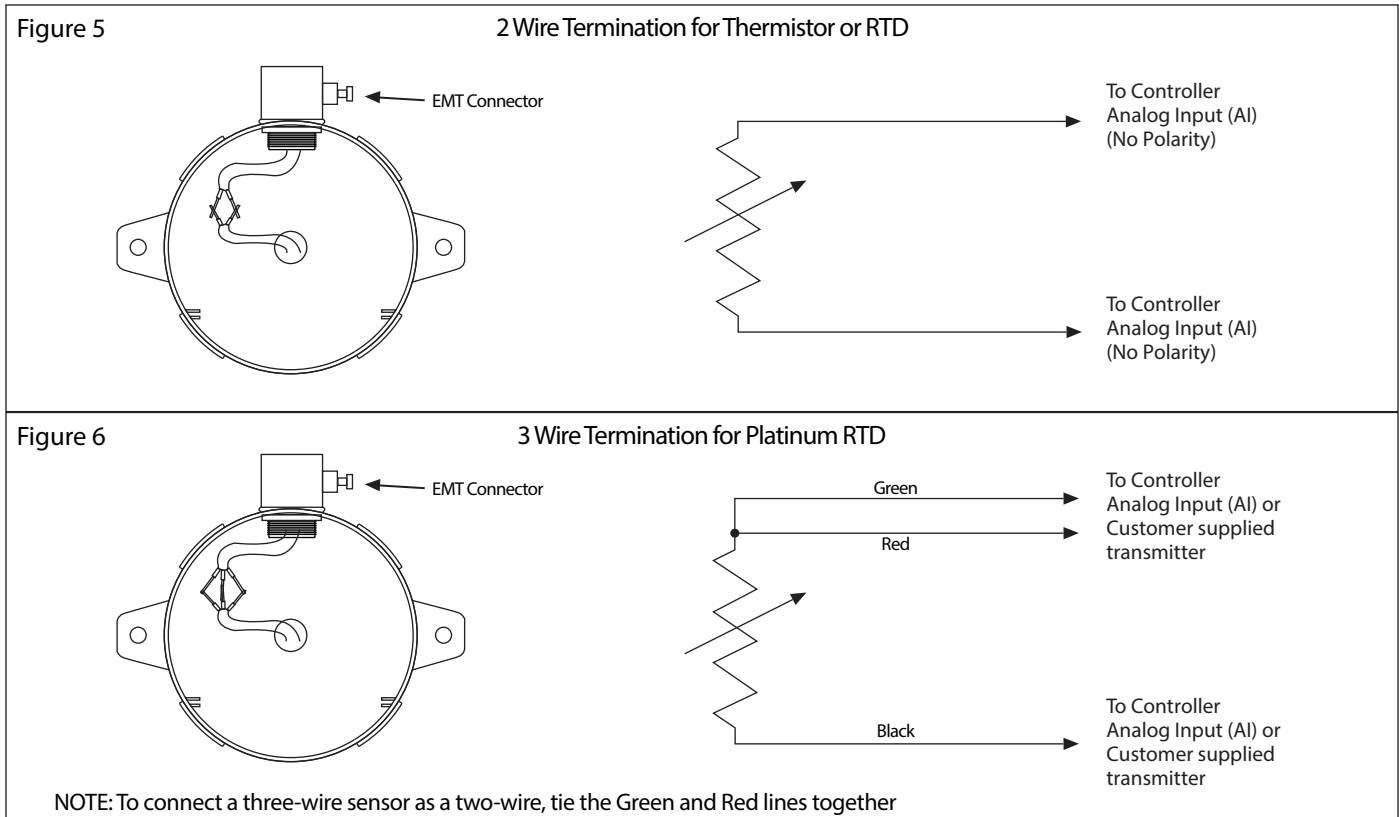

Specification:

Sensor Type:.....Various thermistors or RTD
 Accuracy..... **RTD Class A:** ±0.15°C @ 0°C
 RTD 1/3 DIN: ±0.1°C @ 0°C
 RTD 1/10 DIN: ±0.03°C @ 0°C
 NTC Thermistor Type 39 : ±0.05°C, 0-70°C
 NTC Thermistor Type 55: ±0.03°C, 0-70°C
 NTC Thermistor Type 40/46 : ±0.1°C, 0-70°C
 Temperature Range:..-20 to 105 °C (-4 to 221 °F)
 Wire Material:.....2 wire: PVC insulated, parallel bonded
 3 wire: FT-4
 Probe Material:.....304 Series Stainless Steel
 Probe Dimensions:.....0.25" (6.35 mm) Diameter
 Standard lengths: 50, 100, 150, 200, 300, 450 mm
 (2", 4", 6", 8", 12", 18")
 Fitting.....1/2" NPT Nylon w/ friction fit probe
 Enclosure:.....ABS - UL94-V0 - IP65 (NEMA4X)
 Termination:.....2 or 3 wire pigtail.

Typical Wire Resistance Values

When using low resistance sensors, long wire runs can add significant error to the readings. Use the following chart to determine errors due to wire resistance or consider using a 1000 ohm sensor or a transmitter for better accuracy. Locate the type of wire being used. Multiply the total length of the wire (distance from the controller to the sensor and back) by the number found in the chart below for total resistance.

GAUGE WIRE TYPE	18 AWG	22 AWG	24 AWG
STRANDED (OHMS/FOOT)	5.85 mΩ	14.75 mΩ	23.29 mΩ
SOLID (OHMS/FOOT)	6.4 mΩ	15.85 mΩ	25.72 mΩ

Dimensions:

