

High Accuracy Outside Air Network Temperature Sensor

Installation Instructions

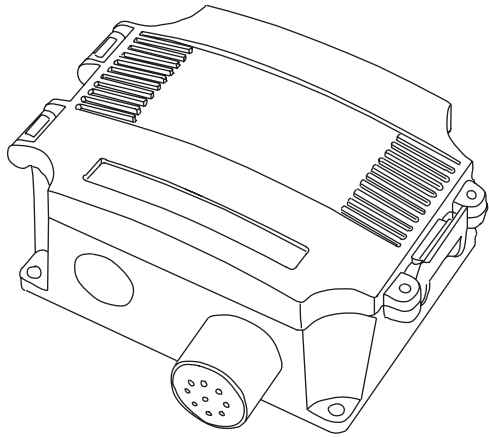

INTRODUCTION

The outside RH/T network sensor uses a highly accurate and reliable Thermoset Polymer based capacitance humidity sensor and curve-matched NTC thermistor temperature sensor together with state-of-the-art digital linearization and temperature compensated circuitry to monitor outside humidity and temperature levels and transmit values via BACnet® communication to a building automation system. A hinged, gasketed weatherproof ABS enclosure provides easy of installation and protection from the elements.

BEFORE INSTALLATION

Read these instructions carefully before installing and commissioning the sensor. Failure to follow these instructions may result in product damage. Do not use in an explosive or hazardous environment, with combustible or flammable gases, as a safety or emergency stop device or in any other application where failure of the product could result in personal injury. Take electrostatic discharge precautions during installation and do not exceed the device ratings.

Select a suitable mounting spot on an exterior wall where the RH/T sensor is best protected from direct exposure to sunlight, wind, etc. preferably on a north facing wall. Do not mount the sensor near opening windows, supply/exhaust air louvres or other known air disturbances. Avoid areas where the sensor is exposed to vibrations or rapid temperature changes.

A connection hole for 1/2" Conduit is provided. Run a length of conduit through exterior wall and seal. Use 14-22 AWG shielded wiring for all connections and do not locate the device wires in the same conduit with wiring used to supply inductive loads such as motors. Make all connections in accordance with national and local codes.

MOUNTING

The RH/T sensor installs directly on an exterior wall using the four integrated mounting holes provided on the enclosure. Select the best mounting based on the exterior wall material. The 4 mounting holes will facilitate a #10 size screw (not supplied). The sensor fitting must be pointing down. See Figure 1.

The ABS enclosure has a hinged cover with latch. Open the cover by removing the 2 security screws and then pull slightly on the latch on the right side of the enclosure. At the same time pulling on the cover, as illustrated in Figure 2.

Feed conduit through the provided hole in bottom of enclosure and secure with a lock nut as show in Figure 3. It is recommended that weatherproof conduit or cable gland fittings be used.

Make wiring connections as per the "Wiring" illustrations on Page 2.

Swing door closed until securely latched. Replace the 2 security screws as shown in Figure 4.

Figure 1

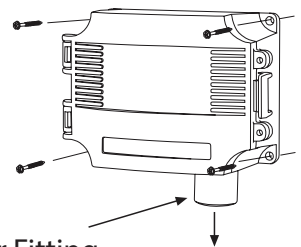

Figure 2

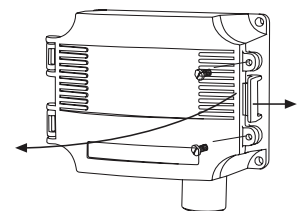

Figure 3

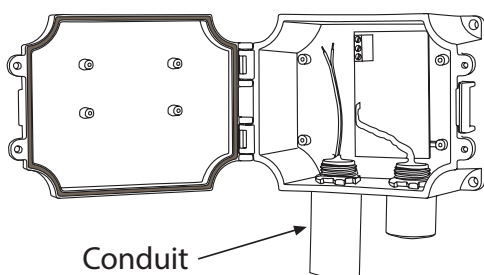
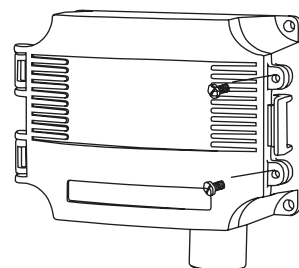

Figure 4



WIRING

Deactivate the 24 Vac/dc power supply until all connections are made to the device to prevent electrical shock or equipment damage. Follow proper electrostatic discharge (ESD) handling procedures when installing the device or equipment damage may occur. Use 22 AWG shielded wiring for all connections and do not locate the device wires in the same conduit with wiring used to supply inductive loads such as motors. Make all connections in accordance with national and local codes.

Connect the 24 Vac/dc power supply to the terminals labeled PWR (power) and COM (common) as shown in Figure 6. This device has a half-wave type power supply so use caution when wiring multiple devices so that the circuit ground point is the same on all devices and the controller. Use caution if 24 Vac power is used and one side of the transformer is earth-grounded. In general, the transformer should NOT be connected to

Figure 5

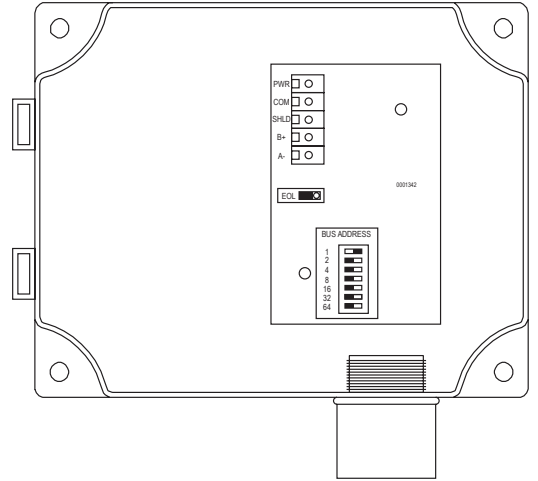
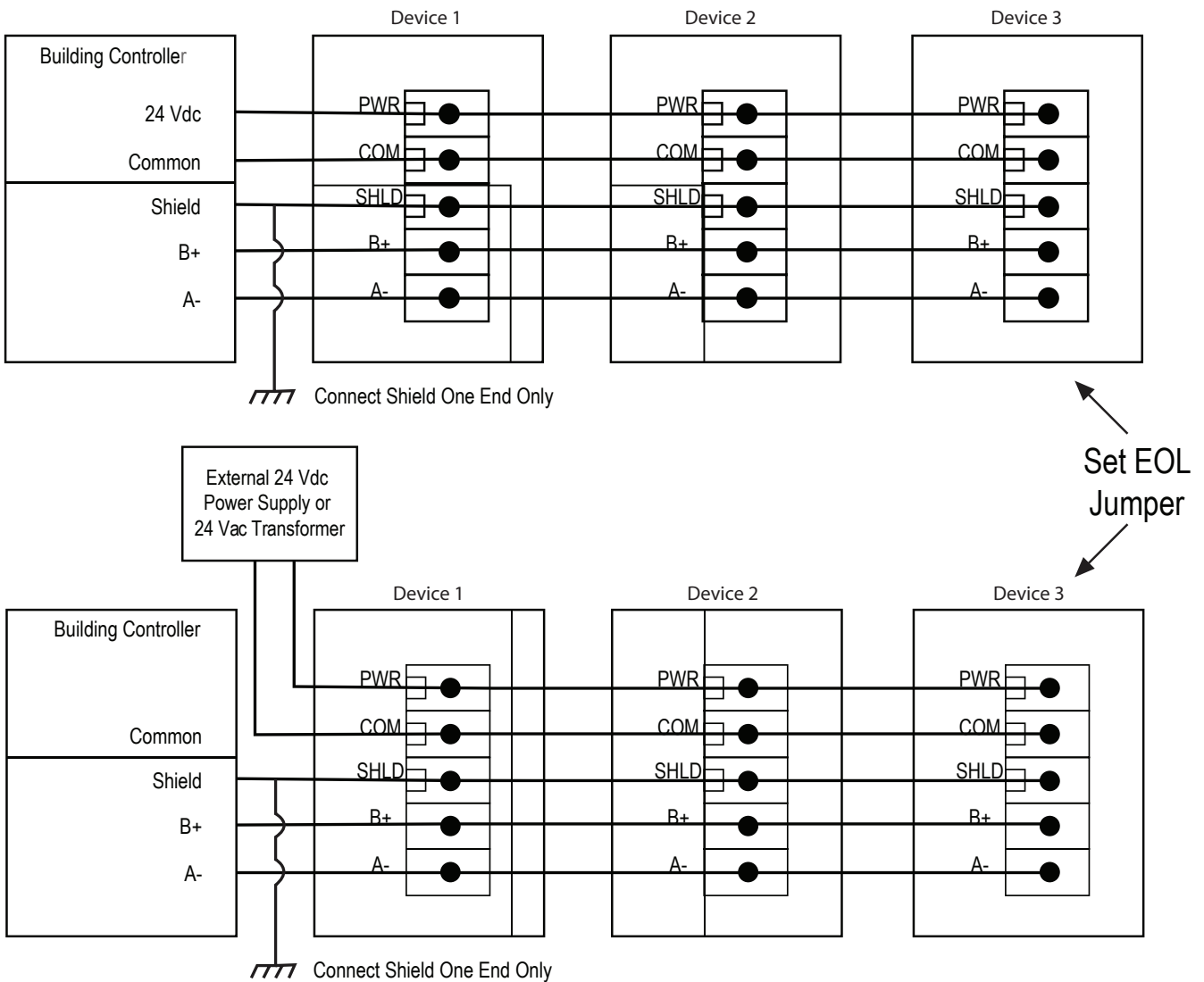

Figure 6



earth ground when using devices with RS-485 network connections. The device is reverse voltage protected and will not operate if connected backwards.

Connect the RS-485 network with twisted shielded pair to the terminals marked A-, B+ and SHLD (shield) as shown in Figure 6. The positive wire connects to B(+) and the negative wire connects to A(-) and the cable shield must be connected to the SHLD terminal

Figure 7

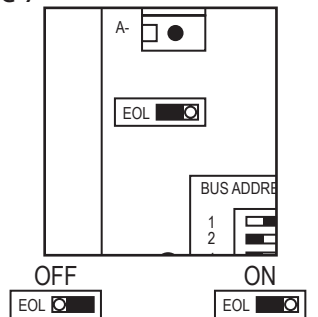

on each device. If the device is installed at either end of the network, an end-of-line (EOL) termination resistor (121 ohm) should be installed in parallel to the A(-) and B(+) terminals. This device includes a network termination jumper and will connect the resistor correctly on the pcb. Simply move the pcb jumper to the EOL position and no external resistor is required as shown in Figure 7. The ground wire of the shielded pair should be connected to earth ground at the end of the network and the master is not grounded. Do not run bus wiring in the same conduit as line voltage wiring.

A network segment is a single shielded wire loop run between several devices (nodes) in a daisy chain configuration. The total segment length should be less than 4000 feet (1220 meters) and the maximum number of nodes on one segment is 127. Nodes are any device connected to the loop and include controllers, repeaters and sensors such as the RH/T Sensor but does not include the EOL terminators. To install more devices, or to increase the network length, repeaters will be required for proper communication. The maximum daisy chain length (segment) depends on transmission speed (baud rate), wire size and number of nodes. If communication is slow or unreliable, it may be necessary to wire two daisy chains to the controller with a repeater for each segment.

NETWORK COMMUNICATION

The device parameters must be set before connection to the network and will ensure that each device has a unique MAC address and Device Instance for startup. On startup, the MAC address is appended to the Device Object : Vendor Identifier to create the unique Device Instance (Device Object : Object Identifier). Once connected to a network, the Device Object : Object Identifier can be written to any unique value via BACnet and then the MAC address will no longer be appended to the value. All parameters are saved in memory. The DIP switch is used to set the BACnet address (0-127). Slide the

Figure 8

DIP Switch Position							BACnet® Address
64	32	16	8	4	2	1	
OFF	OFF	OFF	OFF	OFF	OFF	OFF	0
OFF	OFF	OFF	OFF	OFF	OFF	ON	1
OFF	OFF	OFF	OFF	OFF	ON	OFF	2
OFF	OFF	OFF	OFF	OFF	ON	ON	3
ON	ON	ON	ON	ON	ON	OFF	126
ON	ON	ON	ON	ON	ON	ON	127

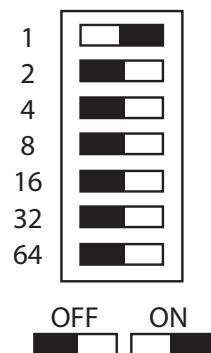

appropriate DIP switch(s) to the “ON” position as shown in Figure 8.

Note that the BACnet network baud rate may be 9600, 19200, 38400, 57600, 76800 or 115200 and is auto-detected on startup.

The RH/T Sensor operates as a slave. It will not communicate unless a master is connected to the network and sends a request for information, then the slave will answer. If the device does not communicate properly, first check that the communication wires are not reversed. Then check that the slave address has a unique setting for the network segment it is connected to. Ensure the device object name and object identifier are unique on the entire BACnet network, not just on the MS/TP sub-net. Both of these properties are writable.

Ensure the application software is not set to poll the devices too frequently. For example, if the software is polling the devices every 500 mS, the network could be heavily congested with the network traffic and may not operate reliably. A slower polling rate such as 5 to 10 seconds will usually produce better results on a typical network segment.

Use care when setting the MS/TP MAC address and the device object Max_Master property since both can have a significant effect on the network efficiency. Some MAC address and Max_Master combinations will operate more efficiently than others. MAC addresses should be selected sequentially,

starting at the lowest possible value. For example, on a five node segment, the MAC addresses should be set to 1, 2, 3, 4 and 5. In this case, if the Max_Master property value is left at the 127 default, then there will be a lot of wasted time on the network polling for masters that are not present. In this example, the five RH/T nodes should be set such that Max_Master is equal to 5. The Max_Master value initially defaults to 127 so that any master can be found when the device first starts.

SPECIFICATIONS

General Specifications

Power Supply 24 Vac/dc \pm 10% (non-isolated half-wave rectified)
 Consumption 25 mA max @ 24 Vdc
 Protection Circuitry Reverse voltage protected, overvoltage protected
 Operating Conditions -40 to 50°C (-40 to 122°F), 0 to 95 %RH non-condensing
 Enclosure ABS, UL94-V0, IP65 (NEMA 4X)
 Dimensions 145 W x 100 H x 64 D mm (5.7" x 3.95" x 2.5")
 Wiring Connections Screw terminal block (14 to 22 AWG)
 Sensing Probe 20 mm (0.8") long x 28 mm (1.1") diameter PVC hub with mesh filter
 Country of Origin Canada

Interface

Hardware 2-wire RS-485
 Software Native BACnet® MS/TP protocol
 Baud Rate 9600, 19200, 38400, 57600, 76800 or 115200 auto-detect
 Network Address Range Locally set to 0-127

Temperature Signal

Sensing Element 20KΩ NTC thermistor
 Accuracy \pm 0.1°C (\pm 0.18°F) curve matched
 Range -40 to 50°C (-40 to 122°F)
 Resolution 0.1°C/°F

RH Signal

Sensor Thermoset polymer based capacitive
 Accuracy \pm 1 %RH (20 to 80 %RH)
 Range 0 to 100 %RH
 Resolution 0.1 %RH
 Hysteresis \pm 1.5 %RH
 Response Time 15 seconds typical
 Stability \pm 1.2 %RH typical @ 50 %RH in 5 years

DIMENSIONS

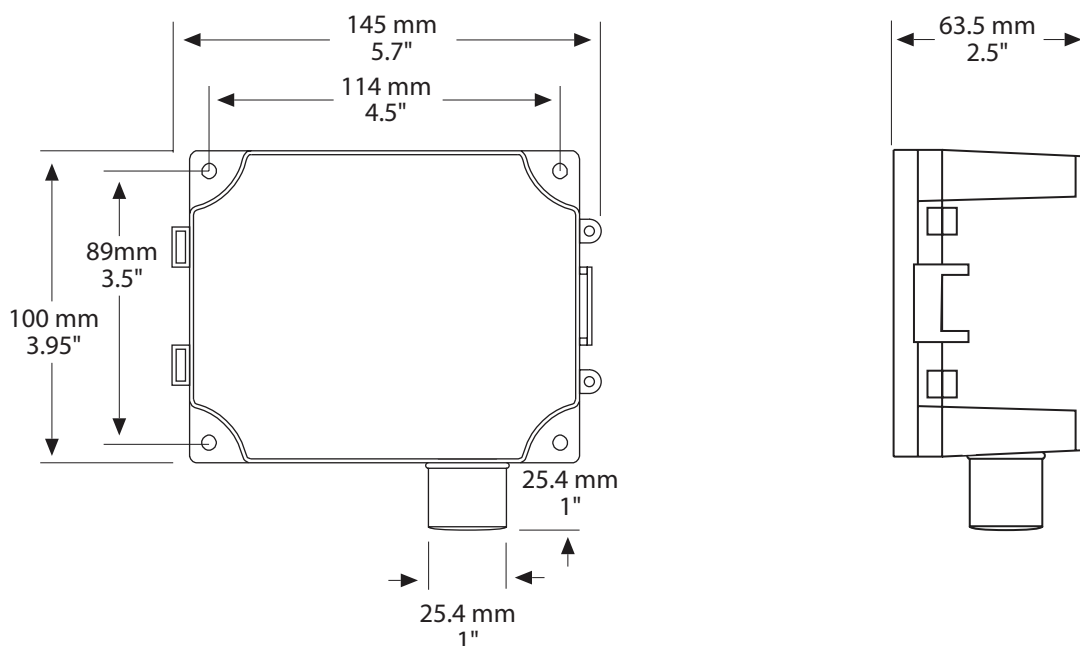

NETWORK SETUP GUIDE

The network setup guide describes the implementation of the BACnet® protocol. It is intended to assist control system programmers who may need to add support to their systems to communicate with this device.

BACnet® setup guide download is available online.



BACnet® PROTOCOL

<http://downloads.greystoneenergy.com/Website%20Documents/NTRC/SG-NTRCXXXBAC-01-01.pdf>