

## INTRODUCTION

The high accuracy duct humidity transmitter uses a highly accurate and reliable Thermoset Polymer based capacitance humidity sensor and state-of-the-art digital linearization and temperature compensated circuitry to monitor humidity levels in a duct. The humidity sensor is encapsulated in a 60 micron HDPE filter at the end of a 230 mm (9") S/S probe and a compact enclosure. An optional high accuracy temperature sensor is available.

## BEFORE INSTALLATION

Read these instructions carefully before installing and commissioning the humidity transmitter. Failure to follow these instructions may result in product damage. Do not use in an explosive or hazardous environment, with combustible or flammable gases, as a safety or emergency stop device or in any other application where failure of the product could result in personal injury. **Take electrostatic discharge precautions during installation and do not exceed the device ratings.**

## MOUNTING

The transmitter installs directly into any air duct with a minimum width/diameter of 25.5 cm (10"). Select a suitable installation area in the middle of the duct wall. To achieve the best reading, do not place in an area where air stratification may be present. Mount the sensor at least 1.5 m (5') in either direction from elbows, dampers, filters or other duct restrictions. Avoid areas where the transmitter is exposed to vibrations or rapid temperature changes.

Once a suitable spot is selected, drill a 15 -20 mm (0.6" - 0.75" ) hole for the probe.

Slide the probe in the drilled hole until the enclosure is flush against the duct. The airflow direction is not important. Secure the enclosure to the duct with two #10 x 1" (25 mm) self tapping screws (not provided). Tighten screws until the enclosure is tight against the duct so that there is no movement of the enclosure as shown in Figure 1.

A foam gasket is provided on the back of the enclosure that provides a tight seal against any air leaks.

The enclosure has a hinged cover with a latch. Open the cover by pulling slightly on the latch on the right side of the enclosure. At the same time pulling on the cover, as shown in Figure 2.

A 1/2" NPT threaded connection hole is provided in the bottom of the enclosure. Screw the EMT or cable gland connector in until tight. See Figure 3. It is recommended that weatherproof EMT or cable gland fittings be used. The E style enclosure includes 1/2" NPT to M16 thread adapter and cable gland fitting.

Make wire connections as per the "Wiring" illustrations on Page 2.

Swing door closed until securely latched. For added security, two screws are provided that may be installed in the integrated screw tabs. See Figure 4.

Figure 1

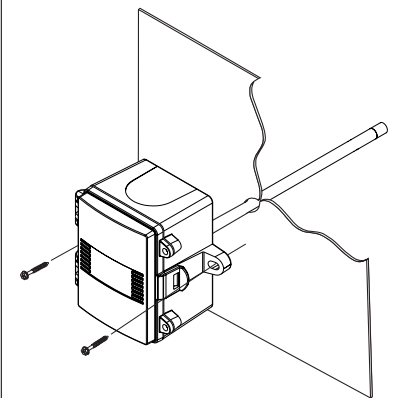

Figure 2

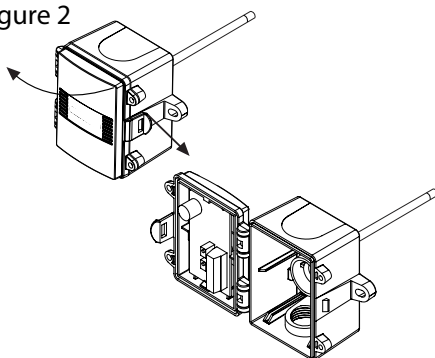

Figure 3

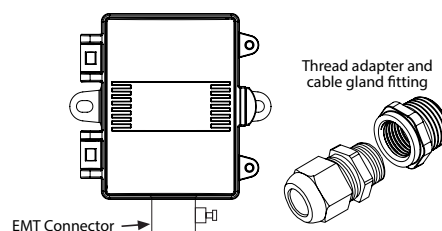
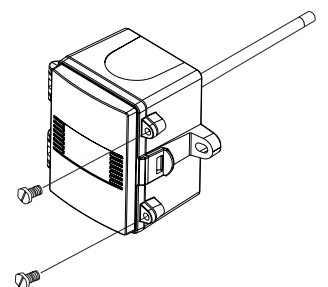
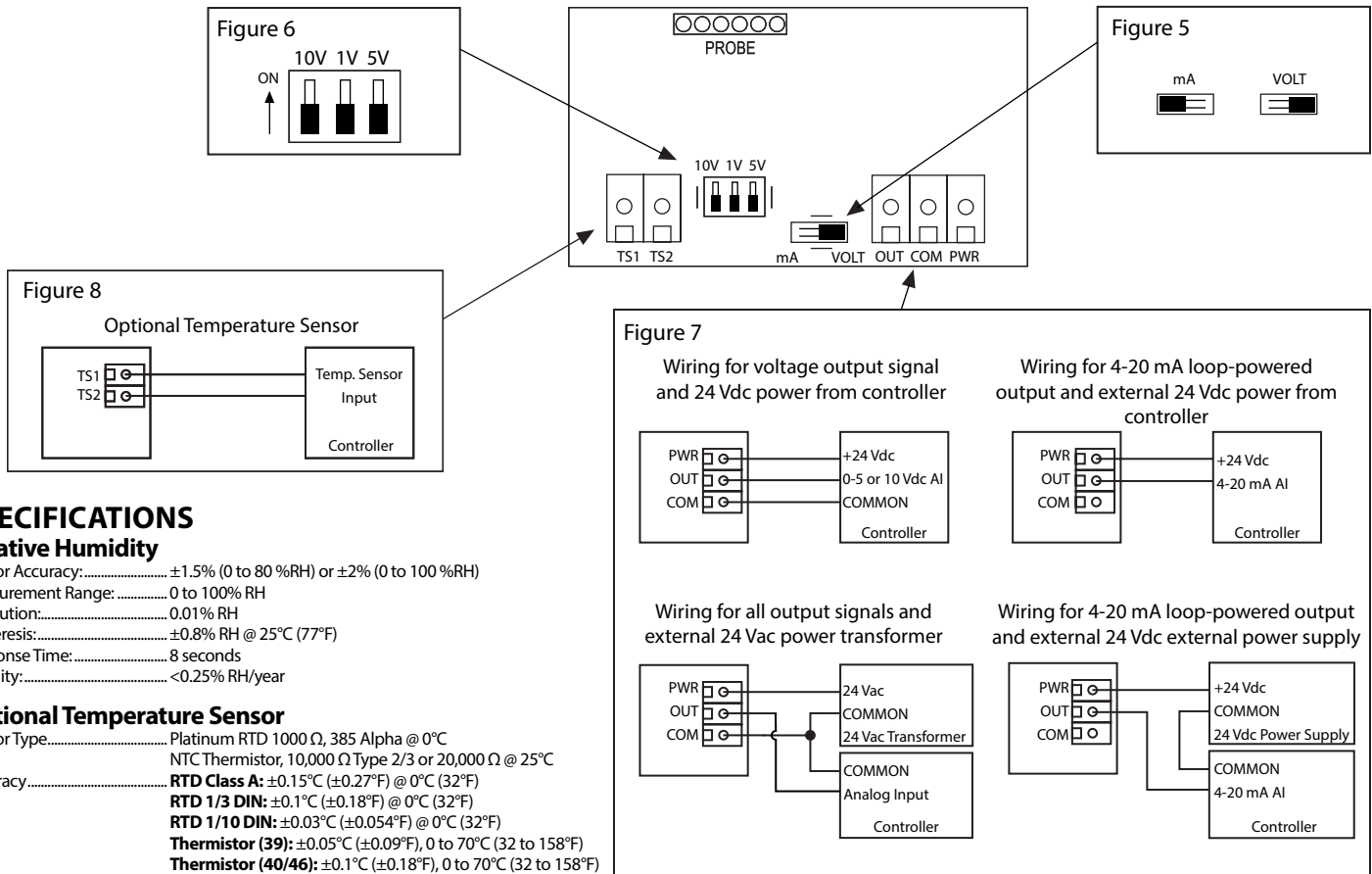

Figure 4



## WIRING

- Deactivate the 24 Vac/dc power supply until all connections are made to the device to prevent electrical shock or equipment damage.
- Use 14-22 AWG shielded wiring for all connections and do not locate the device wires in the same conduit with wiring used to supply inductive loads such as motors. Make all connections in accordance with national and local codes.
- Pull at least six inches of wire into the enclosure, then complete the wiring connection according to the wire diagram for the applicable power supply and output signal type as shown in Figure 7.
- Select desired signal output type (mA or Vdc) by setting switch on PCB to desired output configuration (mA or V) as shown in Figure 5.
- If mA was selected, no further Output set up is required. If VOLT output is selected in Figure 5, Set DIP switch for desired voltage output as shown in Figure 6. Setting one DIP switch to ON position will select the output (10V, 5V or 1V). NOTE: Only one of the Voltage select switches should be in the ON position.
- Connect the DC positive or the AC voltage hot side to the PWR terminal. For voltage output or AC power, the supply Common is connected to the COM terminal. The device is reverse voltage protected and will not operate if connected backwards. It has a half-wave power supply so the supply Common is the same as the signal Common. See Figure 7.
- The analog output is available on the OUT terminal. Check the controller Analog Input to determine the proper connection before applying power as shown in Figure 7.
- If installed, the resistance temperature output is available on the two terminals labeled TS1 and TS2 as shown in Figure 8.
- The RH and Temperature sensor PCB can be field replaced by removing filter at end of Duct Probe. Please refer to the product submittal sheet for replacement sensor selection.



## SPECIFICATIONS

### Relative Humidity

Sensor Accuracy:.....±1.5% (0 to 80 %RH) or ±2% (0 to 100 %RH)  
 Measurement Range:.....0 to 100% RH  
 Resolution:.....0.01% RH  
 Hysteresis:.....±0.8% RH @ 25°C (77°F)  
 Response Time:.....8 seconds  
 Stability:.....<0.25% RH/year

### Optional Temperature Sensor

Sensor Type.....Platinum RTD 1000 Ω, 385 Alpha @ 0°C  
 NTC Thermistor, 10,000 Ω Type 2/3 or 20,000 Ω @ 25°C  
 Accuracy.....**RTD Class A:** ±0.15°C (±0.27°F) @ 0°C (32°F)  
**RTD 1/3 DIN:** ±0.1°C (±0.18°F) @ 0°C (32°F)  
**RTD 1/10 DIN:** ±0.03°C (±0.054°F) @ 0°C (32°F)  
**Thermistor (39):** ±0.05°C (±0.09°F), 0 to 70°C (32 to 158°F)  
**Thermistor (40/46):** ±0.1°C (±0.18°F), 0 to 70°C (32 to 158°F)  
**Thermistor (55):** ±0.03°C (±0.054°F), 0 to 70°C (32 to 158°F)

### General

Power Supply:.....24 Vac/dc ~ ±10% typical  
 Consumption:.....22 mA maximum @24Vdc, 70mA @24Vac  
 Operating Range:.....-40 to 60°C (-40 to 140°F)  
 Output Signal:.....4-20 mA current loop, 0-5 Vdc, 0-10 Vdc, or 0-1 Vdc (field selectable)  
 Output Drive @ 24 Vdc:.....**Current:** 550 Ω max  
**Voltage:** 10K Ω min  
 Probe:.....230 mm (9") probe length x 12.7 mm (1/2") diameter stainless steel with porous filter  
 Enclosures:.....**A:** ABS - UL94-V0, IP65 (NEMA4X)  
**E:** Same as A, with thread adapter (1/2" NPT to M16) and cable gland fitting  
 Termination:.....Screw terminal block (14, to 22 AWG)  
 Country of Origin:.....Canada

Figure 7

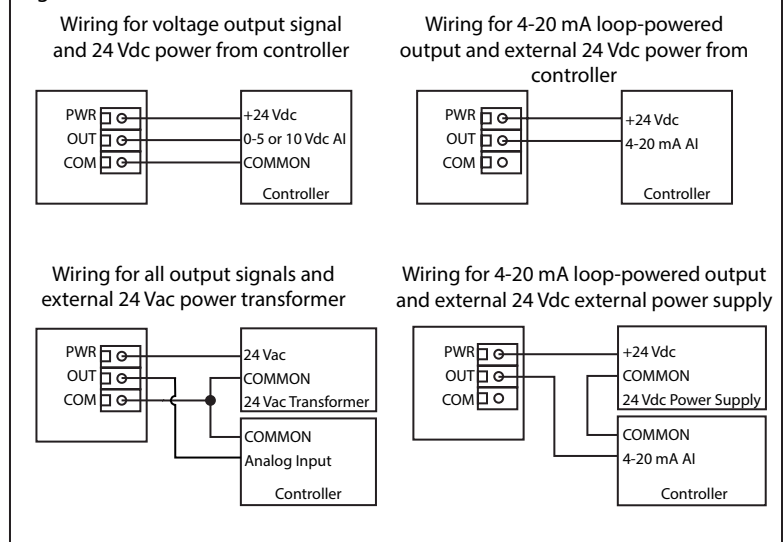

**NOTE:** The temperature sensor accuracies listed in the specifications section apply to the sensing element only prior to product assembly and may not be reflected in the complete assembly.

Due to the measurement uncertainty, it is possible, that the true resistance value of the single delivered sensor at 0°C can be out of the defined tolerance class. Profiling each assembly to take into consideration lead wire and the attachment method should be completed.

## DIMENSIONS

