

High Accuracy Duct Humidity Transmitter

Installation Instructions

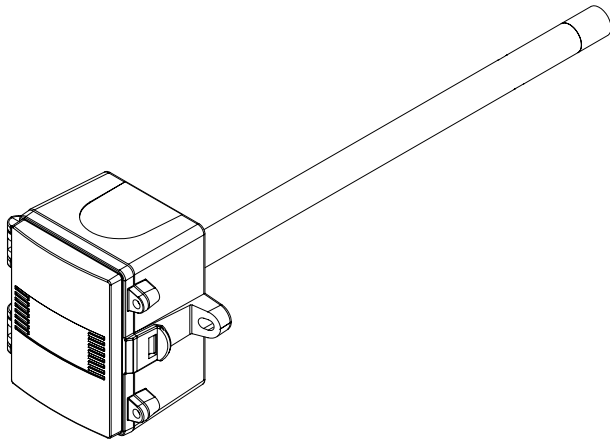

INTRODUCTION

The high accuracy duct humidity transmitter uses a highly accurate and reliable Thermoset Polymer based capacitance humidity sensor and state-of-the-art digital linearization and temperature compensated circuitry to monitor humidity levels in a duct. The humidity sensor is encapsulated in a 60 micron HDPE filter at the end of a 230 mm (9") S/S probe and a compact enclosure. An optional temperature sensor is available.

BEFORE INSTALLATION

Read these instructions carefully before installing and commissioning the humidity transmitter. Failure to follow these instructions may result in product damage. Do not use in an explosive or hazardous environment, with combustible or flammable gases, as a safety or emergency stop device or in any other application where failure of the product could result in personal injury. **Take electrostatic discharge precautions during installation and do not exceed the device ratings.**

MOUNTING

The transmitter installs directly into any air duct with a minimum width/diameter of 25.5 cm (10"). Select a suitable installation area in the middle of the duct wall. To achieve the best reading, do not place in an area where air stratification may be present. Mount the sensor at least 1.5 m (5') in either direction from elbows, dampers, filters or other duct restrictions. Avoid areas where the transmitter is exposed to vibrations or rapid temperature changes.

Once a suitable spot is selected, drill a 15 -20 mm (0.6" - 0.75") hole for the probe.

Slide the probe in the drilled hole until the enclosure is flush against the duct. The airflow direction is not important. Secure the enclosure to the duct with two #10 x 1" (25 mm) self tapping screws (not provided). Tighten screws until the enclosure is tight against the duct so that there is no movement of the enclosure as shown in Figure 1.

A foam gasket is provided on the back of the enclosure that provides a tight seal against any air leaks.

The enclosure has a hinged cover with a latch. Open the cover by pulling slightly on the latch on the right side of the enclosure. At the same time pulling on the cover, as shown in Figure 2.

A 1/2" NPT threaded connection hole is provided in the bottom of the enclosure. Screw the EMT or cable gland connector in until tight. See Figure 3. It is recommended that weatherproof EMT or cable gland fittings be used. The E style enclosure includes 1/2" NPT to M16 thread adapter and cable gland fitting.

Make wire connections as per the "Wiring" illustrations on Page 2.

Swing door closed until securely latched. For added security, two screws are provided that may be installed in the integrated screw tabs. See Figure 4.

Figure 1

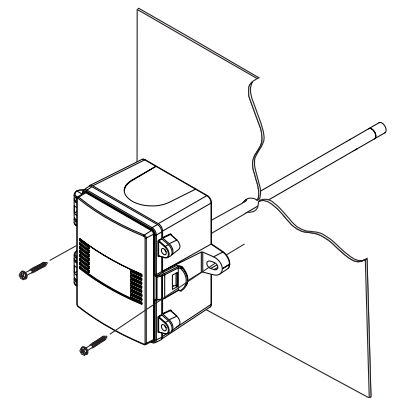

Figure 2

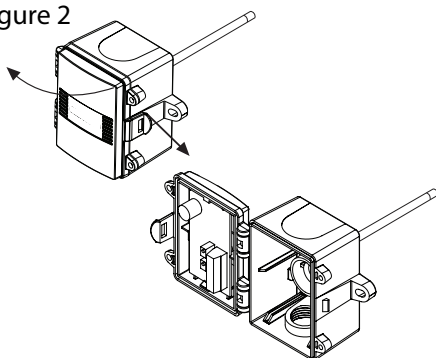

Figure 3

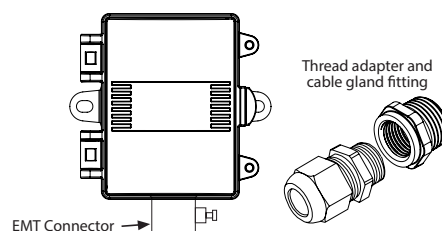
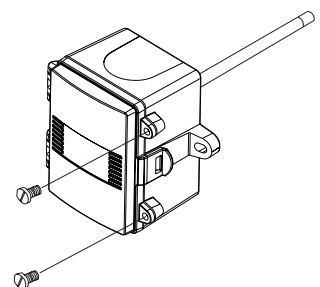
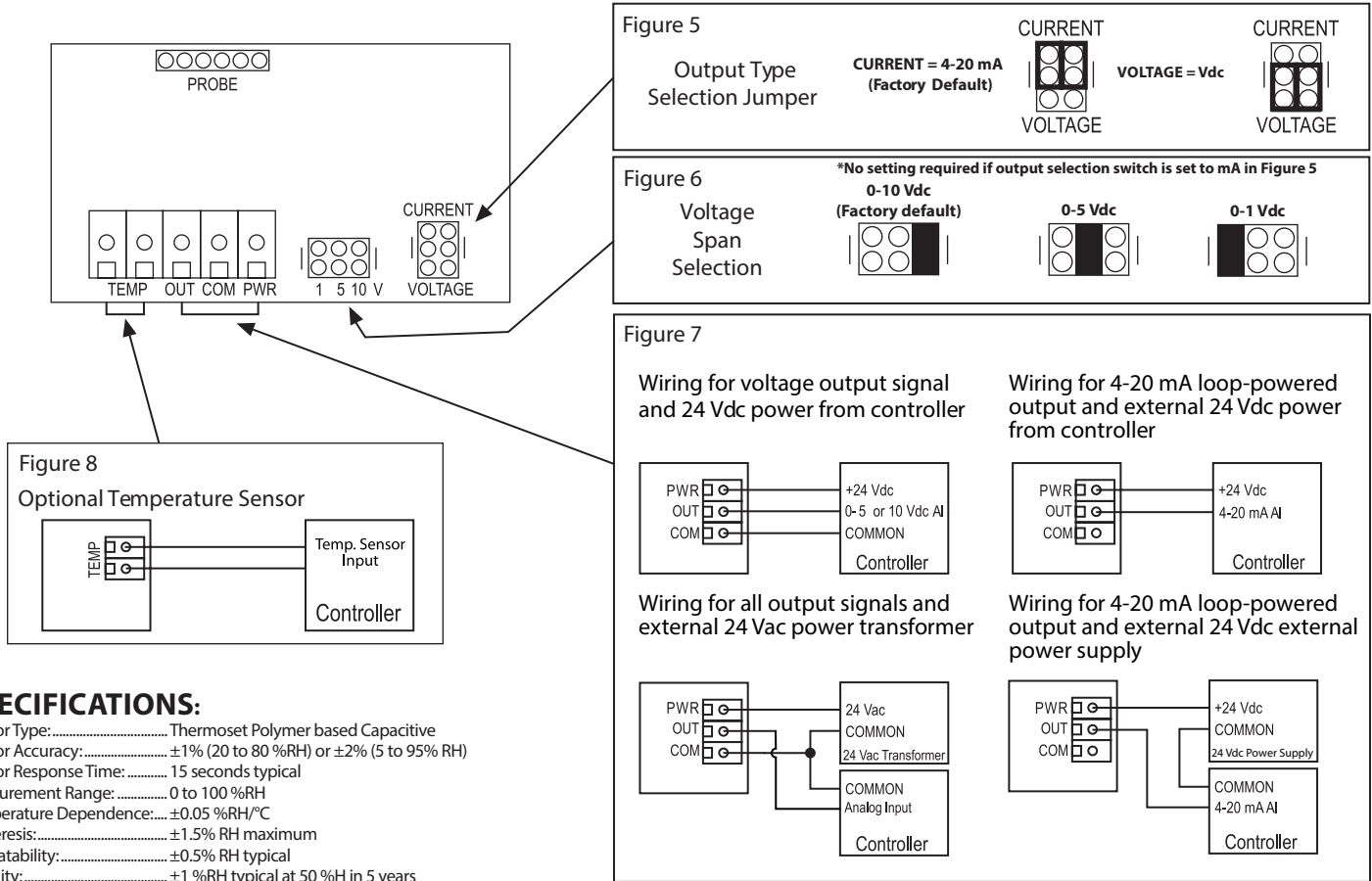

Figure 4



WIRING

- Deactivate the 24 Vac/dc power supply until all connections are made to the device to prevent electrical shock or equipment damage.
- Use 14-22 AWG shielded wiring for all connections and do not locate the device wires in the same conduit with wiring used to supply inductive loads such as motors. Make all connections in accordance with national and local codes.
- Pull at least six inches of wire into the enclosure, then complete the wiring connection according to the wire diagram for the applicable power supply and output signal type.
- Select desired signal output type (mA or Vdc) by placing the output jumper in required position, as shown in Figure 5. Factory default is mA (4-20 mA).
- If mA was selected, no further Output set up is required. If VOLT output is selected in Figure 5, place Voltage Output Jumper to desired span position, as shown in Figure 6. ie: 10 = 0-10 Vdc. Factory default is 0-10 Vdc.
- Connect the DC positive or the AC voltage hot side to the PWR terminal. For voltage output or AC power, the supply Common is connected to the COM terminal. The device is reverse voltage protected and will not operate if connected backwards. It has a half-wave power supply so the supply Common is the same as the signal Common. See Figure 7.
- The analog output is available on the OUT terminal. Check the controller Analog Input to determine the proper connection before applying power as shown in Figure 7.
- If installed, the resistance temperature output is available on the two terminals labeled TEMP as shown in Figure 8.



SPECIFICATIONS:

Sensor Type:..... Thermoset Polymer based Capacitive
 Sensor Accuracy:..... ±1% (20 to 80 %RH) or ±2% (5 to 95% RH)
 Sensor Response Time:..... 15 seconds typical
 Measurement Range:..... 0 to 100 %RH
 Temperature Dependence:..... ±0.05 %RH/°C
 Hysteresis:..... ±1.5% RH maximum
 Repeatability:..... ±0.5% RH typical
 Stability:..... ±1 %RH typical at 50 %H in 5 years
 Ambient Operating Range:.... -40 to 50°C (-40 to 122°F), 5 to 95 %RH non-condensing
 Storage Temperature:..... -30 to 70°C (-22 to 158°F)
 Power Supply:..... 24 Vac/dc ~ ±10% typical, 28 Vac/dc maximum
 Consumption:..... 22 mA maximum
 Input Voltage Effect:..... Negligible over specified operating range
 Protection Circuitry:..... Reverse Voltage protected and output limited
 Output Signal:..... 4-20 mA current loop, 0-5 Vdc, 0-10 Vdc, or 0-1 Vdc (jumper selectable)
 Output Drive @ 24 Vdc:..... **Current:** 550Ωmax
 Voltage: 10,000Ω min

OPTIONAL TEMPERATURE

Sensor Type:..... Platinum RTD 1000 Ω, 385 Alpha @ 0°C
 NTC Thermistor, 10,000 Ω Type 2/3 or 20,000 Ω @ 25°C
 Accuracy..... **RTD Class A:** ±0.15°C (±0.27°F) @ 0°C (32°F)
 RTD 1/3 DIN: ±0.1°C (±0.18°F) @ 0°C (32°F)
 RTD 1/10 DIN: ±0.03°C (±0.054°F) @ 0°C (32°F)
 Thermistor (39): ±0.05°C (±0.09°F), 0 to 70°C (32 to 158°F)
 Thermistor (40/46): ±0.1°C (±0.18°F), 0 to 70°C (32 to 158°F)
 Thermistor (55): ±0.03°C (±0.054°F), 0 to 70°C (32 to 158°F)
 Enclosures:..... **A:** ABS - UL94-V0, IP65 (NEMA4X)
 E: Same as A, with thread adapter (1/2" NPT to M16) and cable gland fitting
 Probe:..... 230mm (9") length x 12.7mm (1/2") diameter s/s with porous filter
 Termination:..... Screw terminal block (14 to 22 AWG)
 Country of Origin:..... Canada

DIMENSIONS

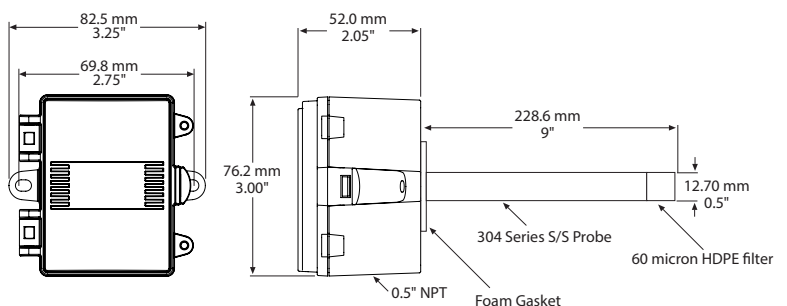

PRINTED IN CANADA