

Modbus Horticulture Sensor

Installation Instructions

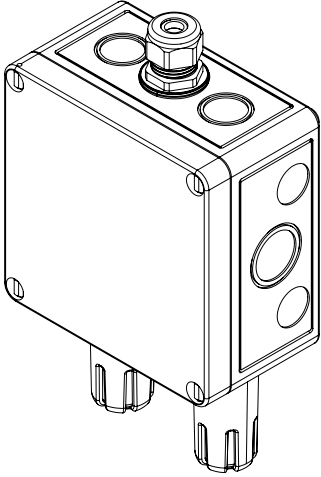

INTRODUCTION

The horticulture sensor series uses a highly accurate and reliable dual channel, Non-Dispersive Infrared (NDIR) sensor to monitor CO₂, a precision thermistor to monitor temperature and a thermoset polymer based capacitance sensor to measure humidity levels.

Features include an LCD for configuration and monitoring, various output signal types, optional relays for alarm indication and field replaceable sensors.

BEFORE INSTALLATION

Read these instructions carefully before installing and commissioning the horticulture sensor. Failure to follow these instructions may result in product damage. Do not use in an explosive or hazardous environment, with combustible or flammable gases, or as a safety or emergency stop device or in any other application where failure of the product could result in personal injury. **Follow electronic discharge precautions during installation and do not exceed the device ratings.**

MOUNTING

Remove the cover by using a standard or flat screwdriver to loosen the four screws as shown in Figure 1. Complete removal of the screw from the cover is not required as the screws are captive type. The horticulture sensor can be mounted directly onto any wall or flat surface, or may be suspended from the ceiling using the device cable harness which is secured to the enclosure with a compression style fitting. An optional cable winder is available to allow easy raising or lowering of the device without tools.

For wall mounting, select a suitable mounting area away from opening windows or doors and avoid areas subject to high vibrations or excessive moisture. Mount the device directly to the flat surface using the four integrated mounting holes that are provided on each corner of the enclosure using #8 size screws (not provided). Ensure the sensor pods are pointing downwards as shown in Figure 2.

After the enclosure is securely mounted to the wall, feed the cable through the cable gland and securely tighten the compression fitting as shown in Figure 3. It is generally easier to prepare the cable by stripping sufficient jacket and wires before feeding the cable through the cable gland.

For suspension mounting, feed the cable through the cable gland and securely tighten the compression fitting as shown in Figure 3. Ensure the cable is also securely fastened to the ceiling mount and that the cable length is sufficient for the required location. Attach the winder to the cable by looping the cable through the cable hooks as shown in figure 4. To adjust the height of the sensor unloop the bottom cable from the cable hook, wrap around the spool until desired height is reached and reconnect to bottom cable hook as shown in figure 4. Each wrap around the spool will raise the sensor approximately 17.78 cm (7").

Figure 1

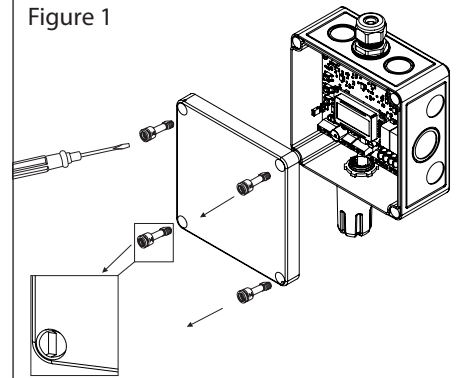

Figure 2

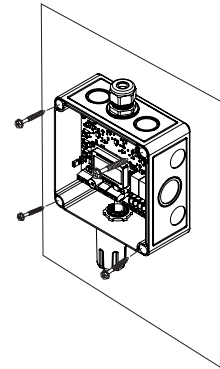

Figure 3

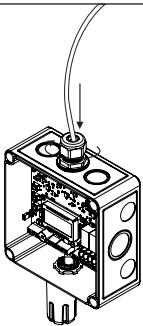

Figure 4

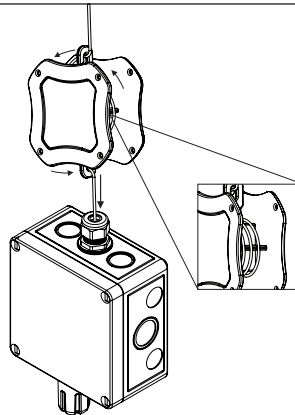
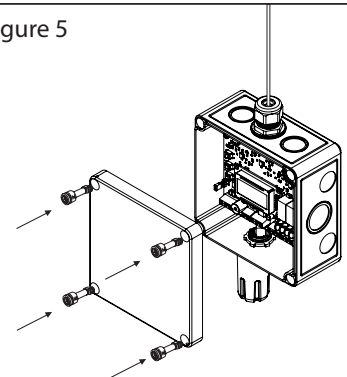

Figure 5



Make wiring connections as per the "Wiring" illustrations. Once the wiring and device setup are complete, re-install the cover and secure with the four screws as shown in Figure 5.

WIRING

Deactivate the 24 Vac/dc power supply until all connections are made to the device to prevent electrical shock or equipment damage. Follow proper electrostatic discharge (ESD) handling procedures when installing the device or equipment damage may occur. Use 14-22 AWG shielded wire for all connections and do not locate the device wires in the same conduit with wiring used to supply inductive loads such as motors. Pull at least six inches of wire into the enclosure and complete the wiring connections according to the wiring diagram. Make all connections in accordance with national and local codes.

Connect the plus DC or the AC voltage hot side to the POWER terminal and the power supply common is connected to the COMMON terminal. The device is reverse voltage protected and will not operate if connected backwards. It has a half-wave power supply so use caution when wiring multiple devices or when grounding the secondary of a transformer to ensure that the circuit ground point is the same on all devices and the controller. In general, the transformer should NOT be connected to earth ground when using devices with RS-485 network connections.

Connect the RS-485 network with twisted shield pair to the terminals marked A-, B+ and SHLD (shield) as shown in Figure 6. The positive wire connects to B+ and the negative wire connects to A- and the cable shield must be connected to the SHLD terminal of each device. If the device is connected to the end of the network, and end-of-line (EOL) termination resistor (121 ohm) should be installed in parallel with the A- and B+ terminals. This device includes a network termination jumper and will connect the resistor correctly on the PCB. Simply move the PCB jumper to the EOL position as shown in Figure 7 and no external resistor is required. The ground wire of the shielded pair should be connected to earth ground at the end of the network and the master is not grounded. Do not run bus wiring in the same conduit as line voltage wiring.

A network segment is a single shielded wire loop run between several devices (nodes) in a daisy chain configuration. The total segment length should be less than 4000 feet (1220 meters) and the maximum number of nodes on one segment is 127. Nodes are any device connected to the loop and include controllers, repeaters and sensors such as the Horticulture Sensor but does not include the EOL terminators. To install more devices, or to increase the network length, repeaters will be required for proper communication. The maximum daisy chain length (segment) depends on transmission speed (baud rate), wire size and number of nodes. If communication is slow or unreliable, it may be necessary to wire two daisy chains to the controller with a repeater for each segment.

The horticulture sensor may have one or two optional relays installed. The relays are Form C type with both a normally open (NO) and a normally closed (NC) contact. The relay contacts may be connected to controller Digital Inputs (DI) for status monitoring or used to directly control an alarm or ventilation fan. Do not exceed the device contact ratings. In some cases a separate control relay may be used between the horticulture sensor relay and a large fan for example.

Relay terminals are designated NO, COM and NC. Each relay output is independent and isolated from the other and the relay COMs are not connected to the device COMMON.

Figure 6

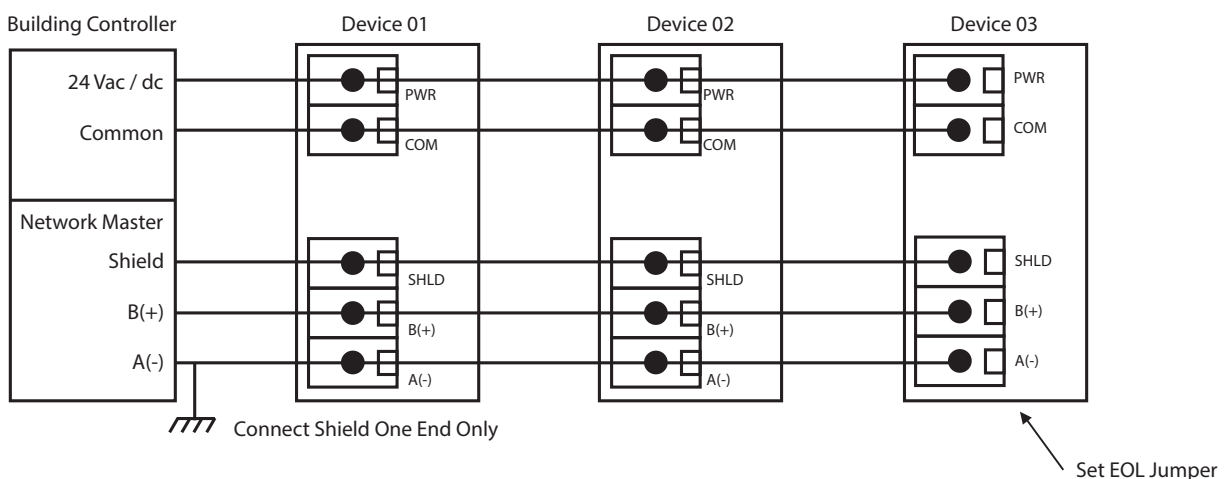

Figure 6

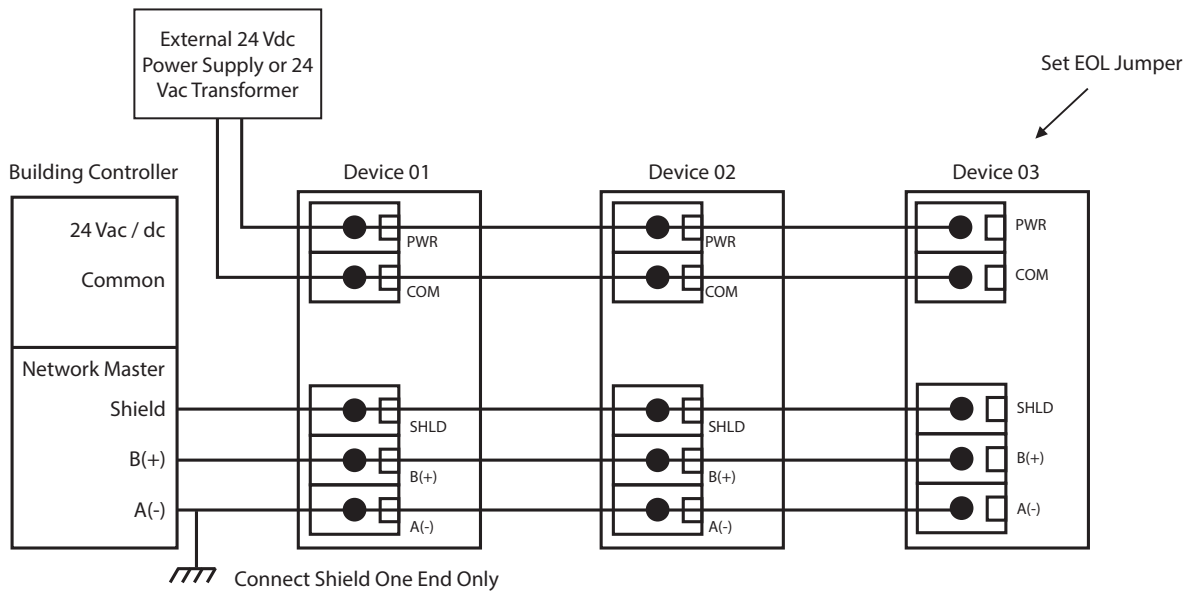
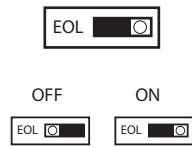

Figure 7



Network Communication

The device parameters must be set before connection to the network and will ensure that each device has a unique ModBus address for startup. The Setup Menu and LCD are used to set the device address (1-255) and the baud rate. The factory defaults are address 3 and 9600 baud. Menu operation is described in detail in the Operation section.

The sensor operates as a slave. It will not communicate unless a master is connected to the network and sends a request for information, then the slave will answer. If the device does not communicate properly, first check that the communication wires are not reversed. Then check that the slave address has a unique setting for the network segment it is connected to. Finally, verify that the device parity bit, stop bit and RTU mode CRC polynomial are correct for the network it is connected to.

Ensure the application software is not set to poll the devices too frequently. For example, if the software is polling the devices every 500 mS, the network could be heavily congested with the network traffic and may not operate reliably. A slower polling rate such as 5 to 10 seconds will usually produce better results on a typical network segment.

Operation - Start-up

After applying power to the device, it will enter the start-up mode and the LCD will indicate the software version number, the output type, the device address and the baud rate for two seconds each. Then the device will start normal operation.

Version
1.00

Out Type
ModBus

Address
3

BaudRate
9600

Operation - Normal

During normal operation, the installed sensor measurements are read and displayed on the LCD. The modbus registers are updated with the appropriate values and alarm conditions are monitored.

The sensor readings are displayed on the LCD depending on the device model and can be configured with the Setup Menu. There are several configurations on how information is displayed, see the Menu section for full details. Example displays are shown below.

50.0°C
5000 ppm

Temp
50.0°C

Humidity
99.9 %RH

CO2
5000 ppm

99.9 %RH
5000 ppm

50C 99RH
5000 ppm

50.0°C
99.9 %RH

122.0°F
99.9 %RH

Operation - Alarms

The device may also have one or two alarm relays installed, depending on the model. Each relay may operate as a high or low alarm and may be assigned to either RH, temperature or CO₂. For each alarm assignment, there are default values for the setpoints, hysteresis and time delay. The default values may be changed within limits as required using the Setup Menu or via the network. The details of each setting and operation is explained in the Setup Menu section.

Operation - Setup Menu

The Setup Menu has several items as shown below. To enter the menu, press and release the <MENU> key while in normal operation. This will enter the Setup Menu step 1, pressing the <MENU> key a second time advances to step 2. Each press of the <MENU> key saves the selection and advances the menu item. The <UP> and <DOWN> keys are used to make changes to program variables by scrolling through the available options.

<MENU> Press and release the <MENU> key to enter the Setup Menu

1. Slave Address

*ModBus
Addr 1*

Use <UP> or <DOWN> to select a unique slave address from 1-255. The default modbus slave address is 1. Hold <UP> or <DOWN> for 1 second to increment quickly.

<MENU> Press to save and advance.

2. Parity

*ModBus
Parity N*

Use <UP> or <DOWN> to select a parity value of N (none), O (odd) or E (even). The default modbus parity bit is N (none).

<MENU> Press to save and advance.

3. Stop Bits

*ModBus
Stop 1*

Use <UP> or <DOWN> to toggle the stop bits between 1 and 2. The default modbus stop bits is 1.

<MENU> Press to save and advance.

4. CRC Value

*ModBus
CRC A001*

Use <UP> or <DOWN> to set the CRC value to A001 (CRC-16 reverse), 1021 (CITT), 8005 (CRC-16), 8408 (CITT reverse). The default CRC polynomial is 0xA001.

<MENU> Press to save and advance.

5. Slave Response Delay

*ModBus
Del MIN*

Use <UP> or <DOWN> to change the value from MIN (minimum) to 50, 100, 150, 200, 250, 300 or 350ms. The default slave response delay is minimum (minimum delay means just more than 3.5 character time delays, 4ms for 9600 baud, for example).

<MENU> Press to save and advance.

6. Baud Rate

*BaudRate
9600*

Use <UP> or <DOWN> to select a baud rate of 9600, 19200, 38400, 57600, 76800 or 115200. Use <MENU> to save and advance. The default network baud rate is 9600.

<MENU> Press to save and advance.

7. Temperature Scale

*Temp C/F
°C*

The temperature scale defaults to Celsius (°C). Use <UP> or <DOWN> to change to Fahrenheit (°F).

<MENU> Press to save and advance.

8. Temperature Offset

T Offset
0°C

This item allows calibration of the temperature sensor. Use <UP> or <DOWN> to add an offset to the temperature measurement. -1 subtracts 1 degree from the temperature and +1 adds 1 degree to the temperature. The range is -10 to +10 °F or -5.0 to +5.0 °C. Resolution is 1 °F or 0.5 °C. Units depends on the previous C/F setting and resets to 0° if C/F is changed.

<MENU> Press to save and advance.

9. Humidity Offset

H Offset
0 %RH

This item allows calibration of the RH sensor. Use <UP> or <DOWN> to add an offset to the RH measurement. -1 subtracts 1 %RH and +1 adds 1 %RH. The range is -10 to +10 %RH.

<MENU> Press to save and advance.

10. CO₂ Calibration

CO₂ Cal
0 ppm

This item allows calibration of the CO₂ sensor. Use <UP> or <DOWN> to add an offset to the CO₂ measurement. -50 subtracts 50 ppm and +50 adds 50 ppm. The range is -300 to +300 ppm.

<MENU> Press to save and advance.

11. Alarm 1 Assignment

Alarm 1
CO₂ High

Alarm1 assignment defaults to CO₂ High Alarm. If there is no CO₂ sensor, then the default is Temp Hi. Use <UP> or <DOWN> to change to CO₂ Low, Temp Hi, Temp Low, RH High or RH Low as required. Note that the CO₂ alarms are only available if the product model includes the CO₂ sensor. If the product has the optional relays, then Alarm1 controls Relay1 and Alarm2 controls Relay2.

<MENU> Press to save and advance.

12. Alarm 1 Setpoint

Alrm1 SP
1500 ppm

The Alarm1 setpoint depends on the Alarm1 assignment set previously as shown in the table. Use <UP> or <DOWN> to change the setting within the limits. Note that the CO₂ setpoint is only available if the product model includes the CO₂ sensor. Note that a high alarm activates when the measurement exceeds the setpoint and a low alarm activates when the measurement goes below the setpoint.

Alarm 1 Assignment	Default Setpoint	Setpoint Range	Resolution
Temp Hi	30°C / 86°F	10 to 40°C / 50 to 104°F	1°
Temp Low	15°C / 59°F	10 to 40°C / 50 to 104°F	1°
RH High	70 %RH	20 to 90 %RH	5 %RH
RH Low	40 %RH	20 to 90 %RH	5 %RH
CO ₂ High	1500 ppm	600 to 4000 ppm	100 ppm
CO ₂ Low	800 ppm	600 to 4000 ppm	100 ppm

<MENU> Press to save and advance.

13. Alarm 1 Hysteresis

Alrm1 Hy
100 ppm

The Alarm1 hysteresis depends on the Alarm1 assignment set previously as shown in the table. Use <UP> or <DOWN> to change the setting within the limits. Note that the CO₂ setting is only available if the product model includes the CO₂ sensor. Note that a high alarm resets when the measurement goes below (setpoint - hysteresis) and a low alarm resets when the measurement goes above (setpoint + hysteresis).

Alarm 1 Assignment	Default Hysteresis	Hysteresis Range	Resolution
Temp Hi or Low	2°C / 4°F	1 to 5°C / 2 to 10°F	1°
RH High or Low	10 %RH	5 to 20 %RH	1 %RH
CO ₂ High or Low	100 ppm	30 to 250 ppm	10 ppm

<MENU> Press to save and advance.

14. Alarm 1 Delay

*A1 Delay
15 Sec*

The Alarm1 Delay default is 15 seconds. This is the delay time after alarm conditions are met before an actual alarm is set. This can be used to prevent false alarms. Use <UP> or <DOWN> to change the setting from 0 to 255 seconds.

<MENU> Press to save and advance.

15. Alarm 2 Assignment

*Alarm 2
CO2 High*

Alarm2 assignment defaults to CO₂ High Alarm. If there is no CO₂ sensor, then the default is Temp Hi. Use <UP> or <DOWN> to change to CO₂ Low, Temp Hi, Temp Low, RH High or RH Low as required. Note that the CO₂ alarms are only available if the product model includes the CO₂ sensor. If the product has the optional relays, then Alarm1 controls Relay1 and Alarm2 controls Relay2.

<MENU> Press to save and advance.

16. Alarm 2 Setpoint

*Alrm2 SP
1800 ppm*

The Alarm2 setpoint depends on the Alarm2 assignment set previously as shown in the table. Use <UP> or <DOWN> to change the setting within the limits. Note that the CO₂ setpoint is only available if the product model includes the CO₂ sensor. Note that a high alarm activates when the measurement exceeds the setpoint and a low alarm activates when the measurement goes below the setpoint.

Alarm 2 Assignment	Default Setpoint	Setpoint Range	Resolution
Temp Hi	30°C / 86°F	10 to 40°C / 50 to 104°F	1°
Temp Low	15°C / 59°F	10 to 40°C / 50 to 104°F	1°
RH High	70 %RH	20 to 90 %RH	5 %RH
RH Low	40 %RH	20 to 90 %RH	5 %RH
CO ₂ High	1500 ppm	600 to 4000 ppm	100 ppm
CO ₂ Low	800 ppm	600 to 4000 ppm	100 ppm

<MENU> Press to save and advance.

17. Alarm 2 Hysteresis

*Alrm2 Hy
100 ppm*

The Alarm2 hysteresis depends on the Alarm2 assignment set previously as shown in the table. Use <UP> or <DOWN> to change the setting within the limits. Note that the CO₂ setting is only available if the product model includes the CO₂ sensor. Note that a high alarm resets when the measurement goes below (setpoint - hysteresis) and a low alarm resets when the measurement goes above (setpoint + hysteresis).

Alarm 2 Assignment	Default Hysteresis	Hysteresis Range	Resolution
Temp Hi or Low	2°C / 4°F	1 to 5°C / 2 to 10°F	1°
RH High or Low	10 %RH	5 to 20 %RH	1 %RH
CO ₂ High or Low	100 ppm	30 to 250 ppm	10 ppm

<MENU> Press to save and advance.

18. Alarm 2 Delay

A2 Delay
15 Sec

The Alarm2 Delay default is 15 seconds. This is the delay time after alarm conditions are met before an actual alarm is set. This can be used to prevent false alarms. Use <UP> or <DOWN> to change the setting from 0 to 255 seconds.

<MENU> Press to save and advance.

19. Display

Display
All

Use <UP> or <DOWN> to set the LCD display information to All, RH, Temp, CO₂, RH-Temp, RH-CO₂, Temp-CO₂ or None. All mean RH/T/CO₂ if the CO₂ sensor is installed or RH/T if it is not. None means no measurements are normally displayed but the start-up mode and menus are still displayed. The factory default is All.

<MENU> Press to save and advance.

20. Backlight

BackLite
Auto

Use <UP> or <DOWN> to set the LCD backlight to On, Off or Auto. When On the LCD backlight is always on, when Off it never lights and if set to Auto it lights for a time period (30 seconds) whenever a key is pressed. Even if set to Off, the backlight will light during the start-up mode. In Auto mode, the backlight will remain lit whenever a menu is open. The factory default is Auto.

<MENU> Press to save and advance.

DIMENSIONS

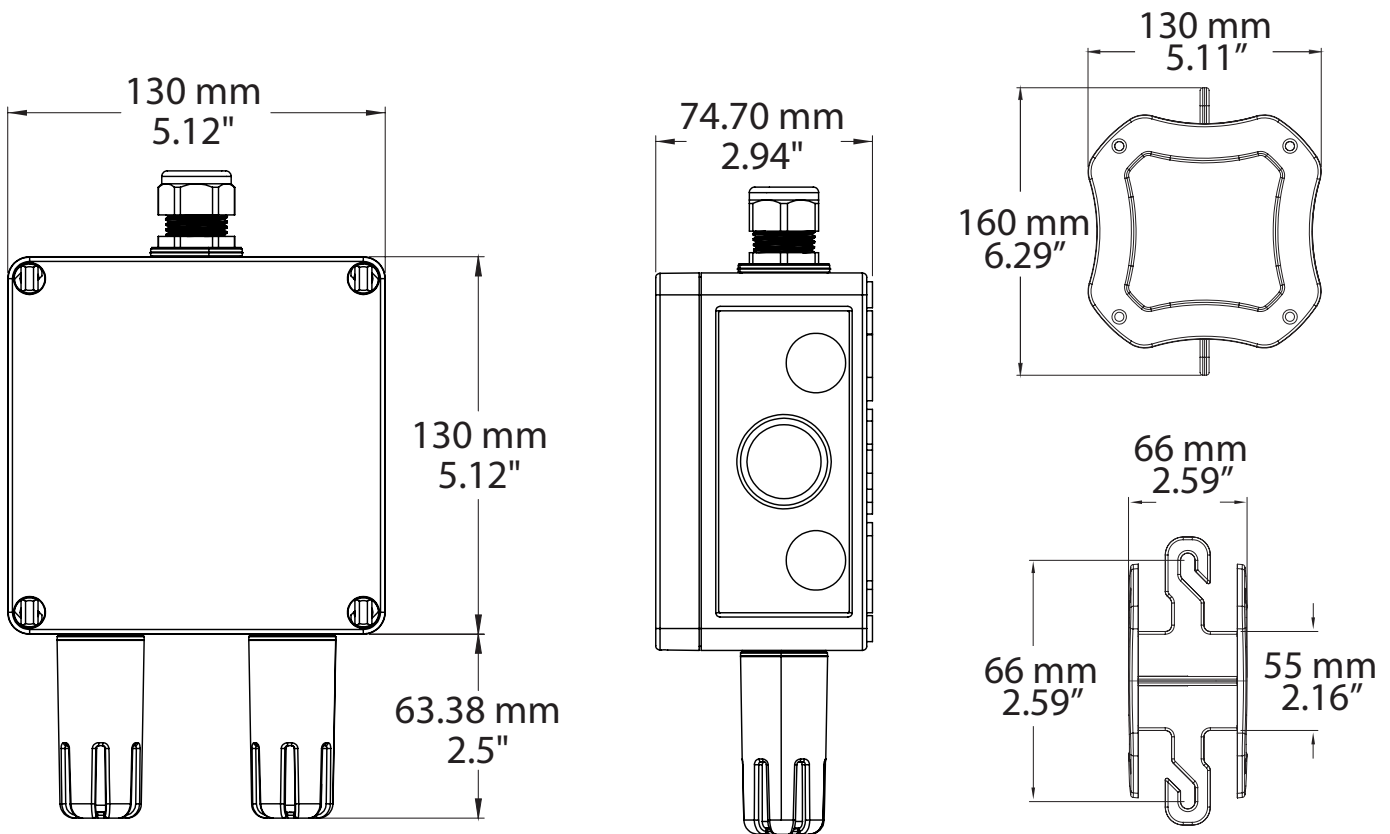

SPECIFICATIONS:

General Specifications

Power Supply	24 Vac/dc $\pm 20\%$ (non-isolated half-wave rectified)
Consumption	75 mA max @ 24 Vdc, 125 mA max @ 24 Vac
Protection Circuitry.....	Reverse voltage protected, overvoltage protected
Operating Conditions	-10 to 50°C (14 to 122°F), 5 to 95 %RH non-condensing
Storage Conditions	-30 to 60°C (-22 to 140°F)
Wiring Connections.....	Screw terminal block (14 to 22 AWG)
Enclosure	IP65 (NEMA 4X) 130 mm W x 130 mm H x 75 mm D (5.12" x 5.12" x 2.95") Cable Winder: 130mm W x 160mm H x 66mm D (5.12" x 6.29" x 2.59")
Country of Origin.....	Canada

LCD Display

Size.....	35 mm x 15 mm (1.4" x 0.6") alpha-numeric 2 line x 8 characters
Backlight.....	Enable or disable via menu or Modbus

Modus

Interface.....	MS/TP, 2 wire RS-485
Baud Rate	9600, 19200, 38400, 57600, 76800, or 115200
Address Range.....	1 to 255

Temperature Signal

Sensing Element.....	10K thermistor
Accuracy	$\pm 0.2^{\circ}\text{C}$ ($\pm 0.4^{\circ}\text{F}$)
Range.....	0 to 50°C (32 to 122°F)

RH Signal

Sensor	Thermoset polymer based capacitive
Accuracy	$\pm 2\%$ RH
Range.....	0 to 100 %RH
Hysteresis	$\pm 1.5\%$ RH
Response Time	15 seconds typical
Stability	$\pm 1\%$ RH typical @ 50 %RH in 5 years

CO₂ Signal

Measurement Type	Dual Channel Non-Dispersive Infrared (NDIR), diffusion sampling
Measurement Range.....	0 to 5,000 ppm
Standard Accuracy	± 50 ppm + 3% of reading
Pressure Dependence.....	<1 % of reading / kPa
Response Time.....	2 minutes (T90)
Sensor Life Span.....	>10 years

Relay Outputs (Optional)

Contact Ratings.....	Form C contact (N.O. + N.C.), 2 Amps @ 140 Vac, 2 Amps @ 30 Vdc
Relay Setpoint & Hysteresis	Programmable via menu or Modbus
Relay Time Delay.....	Programmable via menu or Modbus

NETWORK SETUP GUIDE

The network setup guide describes the implementation of the Modbus protocol. It is intended to assist control system programmers who may need to add support to their systems to communicate with this device.

Modbus setup guide download is available online.



MODBUS PROTOCOL

<http://downloads.greystoneenergy.com/Website%20Documents/GH/SG-GHXXXMOD.pdf>