

# Analog Horticulture Sensor

## Installation Instructions

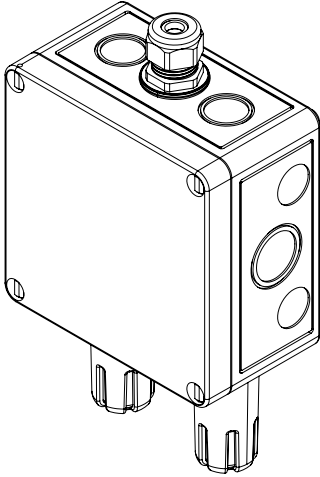

### INTRODUCTION

The horticulture sensor series uses a highly accurate and reliable dual-channel, non-dispersive infrared (NDIR) sensor to monitor CO<sub>2</sub>, a precision thermistor to monitor temperature and a thermoset polymer based capacitance sensor to measure humidity levels.

Features include a LCD for configuration and monitoring, various output signal types, optional relays for alarm indication and field replaceable sensors.

### BEFORE INSTALLATION

Read these instructions carefully before installing and commissioning the horticulture sensor. Failure to follow these instructions may result in product damage. Do not use in an explosive or hazardous environment, with combustible or flammable gases, or as a safety or emergency stop device or in any other application where failure of the product could result in personal injury. **Follow electronic discharge precautions during installation and do not exceed the device ratings.**

### MOUNTING

Remove the cover by using a standard or flat screwdriver to loosen the four screws as shown in Figure 1. Complete removal of the screw from the cover is not required as the screws are captive type. The horticulture sensor can be mounted directly onto any wall or flat surface, or may be suspended from the ceiling using the device cable harness which is secured to the enclosure with a compression style fitting. An optional cable winder is available to allow easy raising or lowering of the device without tools.

**For wall mounting**, select a suitable mounting area away from opening windows or doors and avoid areas subject to high vibrations or excessive moisture. Mount the device directly to the flat surface using the four integrated mounting holes that are provided on each corner of the enclosure using #8 size screws (not provided). Ensure the sensor pods are pointing downwards as shown in Figure 2.

After the enclosure is securely mounted to the wall, feed the cable through the cable gland and securely tighten the compression fitting as shown in Figure 3. It is generally easier to prepare the cable by stripping sufficient jacket and wires before feeding the cable through the cable gland.

**For suspension mounting**, feed the cable through the cable gland and securely tighten the compression fitting as shown in Figure 3. Ensure the cable is also securely fastened to the ceiling mount and that the cable length is sufficient for the required location. Attach the winder to the cable by looping the cable through the cable hooks as shown in figure 4. To adjust the height of the sensor unloop the bottom cable from the cable hook, wrap around the spool until desired height is reached and reconnect to bottom cable hook as shown in figure 4. Each wrap around the spool will raise the sensor approximately 17.78 cm (7").

Figure 1

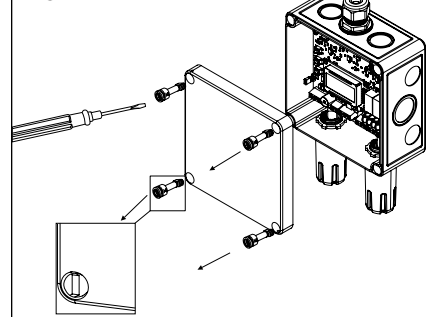

Figure 2

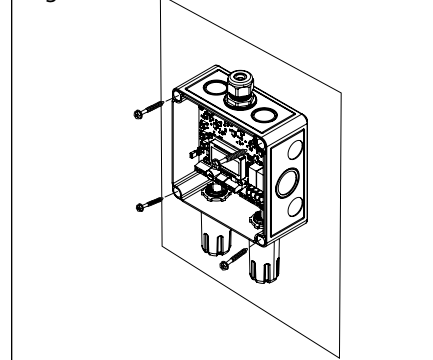

Figure 3

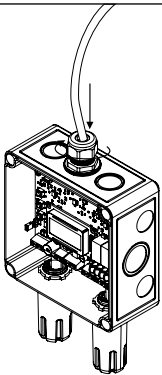

Figure 4

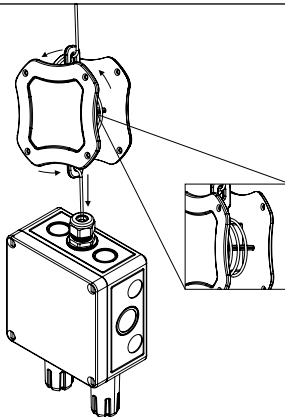
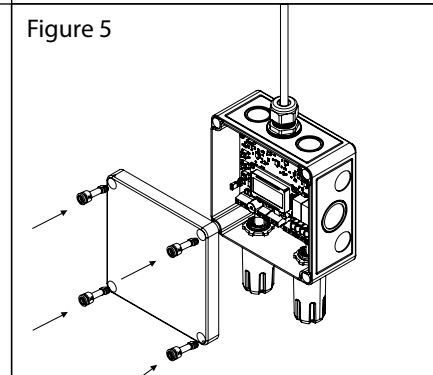

Figure 5



Make wiring connections as per the "Wiring" illustrations. Once the wiring and device setup are complete, re-install the cover and secure with the four screws as shown in Figure 5.

**WIRING**

Deactivate the 24 Vac/dc power supply until all connections are made to the device to prevent electrical shock or equipment damage. Follow proper electrostatic discharge (ESD) handling procedures when installing the device or equipment damage may occur. Use 14-22 AWG shielded wire for all connections and do not locate the device wires in the same conduit with wiring used to supply inductive loads such as motors. Pull at least six inches of wire into the enclosure and complete the wiring connection according to the wiring diagram. Make all connections in accordance with national and local codes.

Connect the plus DC or the AC voltage hot side to the POWER terminal and the power supply common is connected to the COMMON terminal. The device is reverse voltage protected and will not operate if connected backwards. It has a half-wave power supply so the supply common is the same as the signal common. Use caution when wiring multiple devices or when grounding the secondary of a transformer to ensure that the circuit ground point is the same on all devices and the controller.

The analog outputs are available on the CO2, TEMP and RH terminals. The signal type may be ordered as either voltage or 4-20 mA active outputs. The voltage model is selectable for either 0-5 or 0-10 Vdc via the menu (the factory default is 0-5 Vdc). The current outputs operate in the active mode and do not require a loop power supply. This means that the signal current is generated by the horticulture sensor and the outputs must not be connected to a powered input or device damage will result. Check the controller Analog Inputs (AI) to determine proper connection before applying power. Both current and voltage output signals are referenced to the COMMON terminal. The analog output signals are typically connected directly to the Building Automation System (BAS) and used as control parameters.

The horticulture sensor may have one or two optional relays installed. The relays are Form C type with both a normally open (NO) and a normally closed (NC) contact. The relay contacts may be connected to controller Digital Inputs (DI) for status monitoring or used to directly control an alarm or ventilation fan. Do not exceed the device contact ratings. In some cases a separate control relay may be used between the horticulture sensor relay and a large fan for example.

Relay terminals are designated NO, COM and NC. Each relay output is independent and isolated from the other and the relays COMs are not connected to the device COMMON.

Typical wiring diagrams are shown in Figure 6.

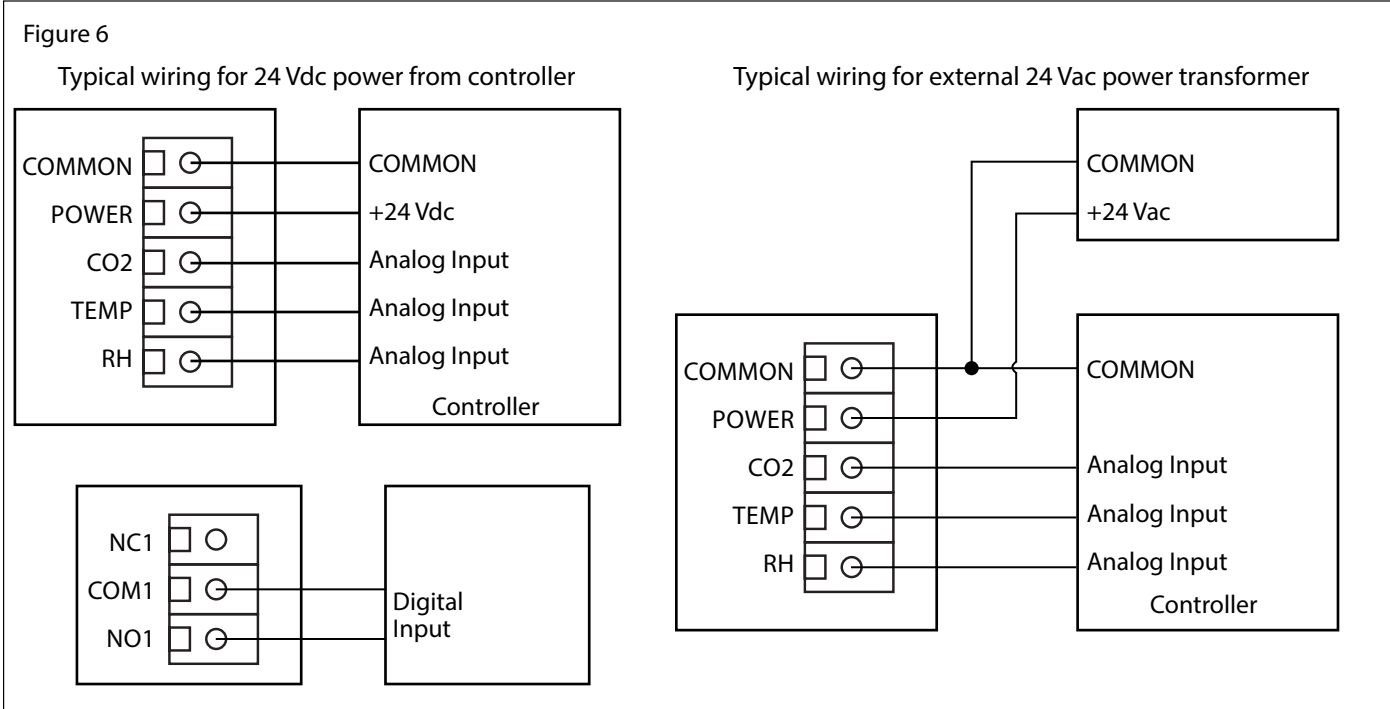

## Operation - Start-up

After applying power to the device, it will enter the start-up mode and the LCD will indicate the software version number and the output signal type for two seconds each. Then the device will start normal operation.

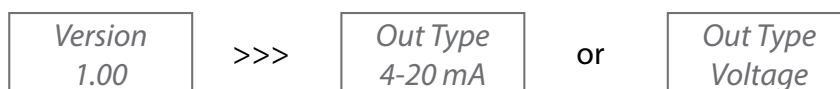

## Operation - Normal

During normal operation, the installed sensor measurements are read and displayed on the LCD. The analog outputs are updated with the appropriate values and alarm conditions are monitored.

The relative humidity output signal is scaled 0-100 %RH = 4-20 mA or 0-5 Vdc depending on the device model. For the voltage output model, the output signal may be changed to 0-10 Vdc by using the Setup Menu.

The temperature output signal is scaled 0-50 °C = 4-20 mA or 0-5/0-10 Vdc depending on the device model. The temperature range may be changed to 32-122 °F via the Setup Menu.

If the model also includes a carbon dioxide sensor, then the output signal is scaled 0-2000 ppm = 4-20 mA or 0-5/0-10 Vdc as above. If required, the CO<sub>2</sub> scale can be changed via the Setup Menu to span values up to 5000 ppm.

The sensor readings are also displayed on the LCD depending on the device model and can also be configured with the Setup Menu. There are several configurations on how information is displayed, see the Menu section for full details. Example displays are shown below.



## Operation - Alarms

The device may also have one or two alarm relays installed, depending on the model. Each relay may operate as a high or low alarm and may be assigned to either RH, temperature or CO<sub>2</sub>. For each alarm assignment, there are default values for the setpoints, hysteresis and time delay. The default values may be changed within limits as required using the Setup Menu. The details of each setting and operation is explained in the Setup Menu section.

## Operation - Setup Menu

The Setup Menu has several items as shown below. To enter the menu, press and release the <MENU> key while in normal operation. This will enter the Setup Menu step 1, pressing the <MENU> key a second time advances to step 2. Each press of the <MENU> key saves the selection and advances the menu item. The <UP> and <DOWN> keys are used to make changes to program variables by scrolling through the available options.

<MENU> Press and release the <MENU> key to enter the Setup Menu

### 1. CO<sub>2</sub> Range

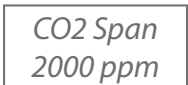
 The default CO<sub>2</sub> range is 0-2000 ppm. The output span can be changed from 2000 to 5000 ppm in increments of 500. Use <UP> or <DOWN> to change the value.

<MENU> Press to save and advance.

### 2. Temperature Scale

 The temperature scale defaults to Celsius (°C). Use <UP> or <DOWN> to change to Fahrenheit (°F).

<MENU> Press to save and advance.

### 3. Temperature Offset

T Offset  
0°C

This item allows calibration of the temperature sensor. Use <UP> or <DOWN> to add an offset to the temperature measurement. Use <MENU> to save and advance. -1 subtracts 1 degree from the temperature and +1 adds 1 degree to the temperature. The range is -10 to +10 °F or -5.0 to +5.0 °C. Resolution is 1 °F or 0.5 °C. Units depends on the previous C/F setting and resets to 0° if C/F is changed.

<MENU> Press to save and advance.

### 4. Humidity Offset

H Offset  
0 %RH

This item allows calibration of the RH sensor. Use <UP> or <DOWN> to add an offset to the RH measurement. Press <MENU> to save and advance. -1 subtracts 1 %RH and +1 adds 1 %RH. The range is -10 to +10 %RH.

<MENU> Press to save and advance.

### 5. CO<sub>2</sub> Calibration

CO<sub>2</sub> Cal  
0 ppm

This item allows calibration of the CO<sub>2</sub> sensor. Use <UP> or <DOWN> to add an offset to the CO<sub>2</sub> measurement. Press <MENU> to save and advance. -50 subtracts 50 ppm and +50 adds 50 ppm. The range is -300 to +300 ppm.

<MENU> Press to save and advance.

— Only if **Relay 1** installed —

### 6. Alarm 1

Alarm 1  
CO<sub>2</sub> High

Alarm1 assignment defaults to CO<sub>2</sub> High Alarm. If there is no CO<sub>2</sub> sensor, then the default is Temp Hi. Use <UP> or <DOWN> to change to CO<sub>2</sub> Low, Temp Hi, Temp Low, RH High or RH Low as required. Note that the CO<sub>2</sub> alarms are only available if the product model includes the CO<sub>2</sub> sensor. If the product has the optional relays, then Alarm1 controls Relay1 and Alarm2 controls Relay2.

<MENU> Press to save and advance.

### 7. Alarm 1 Setpoint

Alrm1 SP  
1800 ppm

The Alarm1 setpoint depends on the Alarm1 assignment set previously as shown in the table. Use <UP> or <DOWN> to change the setting within the limits. Note that the CO<sub>2</sub> setpoint is only available if the product model includes the CO<sub>2</sub> sensor. Note that a high alarm activates when the measurement exceeds the setpoint and a low alarm activates when the measurement goes below the setpoint.

Alarm 1 Assignment	Default Setpoint	Setpoint Range	Resolution
Temp Hi	30°C / 86°F	10 to 40°C / 50 to 104°F	1°
Temp Low	15°C / 59°F	10 to 40°C / 50 to 104°F	1°
RH High	70 %RH	20 to 90 %RH	5 %RH
RH Low	40 %RH	20 to 90 %RH	5 %RH
CO <sub>2</sub> High	1500 ppm	600 to 4000 ppm	100 ppm
CO <sub>2</sub> Low	800 ppm	600 to 4000 ppm	100 ppm

<MENU> Press to save and advance.

### 8. Alarm 1 Hysteresis

Alrm1 Hy  
100 ppm

The Alarm1 hysteresis depends on the Alarm1 assignment set previously as shown in the table. Use <UP> or <DOWN> to change the setting within the limits. Note that the CO<sub>2</sub> setting is only available if the product model includes the CO<sub>2</sub> sensor. Note that a high alarm resets when the measurement goes below (setpoint - hysteresis) and a low alarm resets when the measurement goes above (setpoint + hysteresis).

Alarm 1 Assignment	Default Hysteresis	Hysteresis Range	Resolution
Temp Hi or Low	2°C / 4°F	1 to 5°C / 2 to 10°F	1°
RH High or Low	10 %RH	5 to 20 %RH	1 %RH
CO <sub>2</sub> High or Low	100 ppm	30 to 250 ppm	10 ppm

<MENU> Press to save and advance.

### 9. Alarm 1 Delay

*A1 Delay  
15 Sec*

The Alarm1 Delay default is 15 seconds. This is the delay time after alarm conditions are met before an actual alarm is set. This can be used to prevent false alarms. Use <UP> or <DOWN> to change the setting from 0 to 255 seconds.

<MENU> Press to save and advance.

### 10. Alarm 2 Assignment

*Alarm 2  
CO2 High*

Alarm2 assignment defaults to CO<sub>2</sub> High Alarm. If there is no CO<sub>2</sub> sensor, then the default is Temp Hi. Use <UP> or <DOWN> to change to CO<sub>2</sub> Low, Temp Hi, Temp Low, RH High or RH Low as required. Note that the CO<sub>2</sub> alarms are only available if the product model includes the CO<sub>2</sub> sensor. If the product has the optional relays, then Alarm1 controls Relay1 and Alarm2 controls Relay2.

<MENU> Press to save and advance.

### 11. Alarm 2 Setpoint

*Alrm2 SP  
1800 ppm*

The Alarm2 setpoint depends on the Alarm2 assignment set previously as shown in the table. Use <UP> or <DOWN> to change the setting within the limits. Note that the CO<sub>2</sub> setpoint is only available if the product model includes the CO<sub>2</sub> sensor. Note that a high alarm activates when the measurement exceeds the setpoint and a low alarm activates when the measurement goes below the setpoint.

Alarm 1 Assignment	Default Setpoint	Setpoint Range	Resolution
Temp Hi	30°C / 86°F	10 to 40°C / 50 to 104°F	1°
Temp Low	15°C / 59°F	10 to 40°C / 50 to 104°F	1°
RH High	70 %RH	20 to 90 %RH	5 %RH
RH Low	40 %RH	20 to 90 %RH	5 %RH
CO2 High	1500 ppm	600 to 4000 ppm	100 ppm
CO2 Low	800 ppm	600 to 4000 ppm	100 ppm

<MENU> Press to save and advance.

### 12. Alarm 2 Hysteresis

*Alrm2 Hy  
100 ppm*

The Alarm2 hysteresis depends on the Alarm2 assignment set previously as shown in the table. Use <UP> or <DOWN> to change the setting within the limits. Note that the CO<sub>2</sub> setting is only available if the product model includes the CO<sub>2</sub> sensor. Note that a high alarm resets when the measurement goes below (setpoint - hysteresis) and a low alarm resets when the measurement goes above (setpoint + hysteresis).

Alarm 1 Assignment	Default Hysteresis	Hysteresis Range	Resolution
Temp Hi or Low	2°C / 4°F	1 to 5°C / 2 to 10°F	1°
RH High or Low	10 %RH	5 to 20 %RH	1 %RH
CO <sub>2</sub> High or Low	100 ppm	30 to 250 ppm	10 ppm

Only if **Relay 2** installed

<MENU>

Press to save and advance.

### 13. Alarm 2 Delay

A2 Delay  
15 Sec

The Alarm2 Delay default is 15 seconds. This is the delay time after alarm conditions are met before an actual alarm is set. This can be used to prevent false alarms. Use <UP> or <DOWN> to change the setting from 0 to 255 seconds.

<MENU>

Press to save and advance.

Only if **Output is Voltage**

### 14. Out Type

Out Type  
0-5 Vdc

The default analog output type is 0-5 Vdc. Use <UP> or <DOWN> to change to 0-10 Vdc if required. Use caution that the selected output signal type matches the controller analog input.

<MENU>

Press to save and advance.

### 15. Display Information

Display  
All

Use <UP> or <DOWN> to set the LCD display information to All, RH, Temp, CO<sub>2</sub>, RH-Temp, RH-CO<sub>2</sub>, Temp-CO<sub>2</sub> or None. All mean RH/T/CO<sub>2</sub> if the CO<sub>2</sub> sensor is installed or RH/T if it is not. None means no measurements are normally displayed but the start-up mode and menus are still displayed. The factory default is All.

<MENU>

Press to save and advance.

### 16. Backlight

BackLite  
Auto

Use <UP> or <DOWN> to set the LCD backlight to On, Off or Auto. When On the LCD backlight is always on, when Off it never lights and if set to Auto it lights for a time period (30 seconds) whenever a key is pressed. Even if set to Off, the backlight will light during the start-up mode. In Auto mode, the backlight will remain lit whenever a menu is open. The factory default is Auto.

<MENU>

Press to save and advance.

### DIMENSIONS

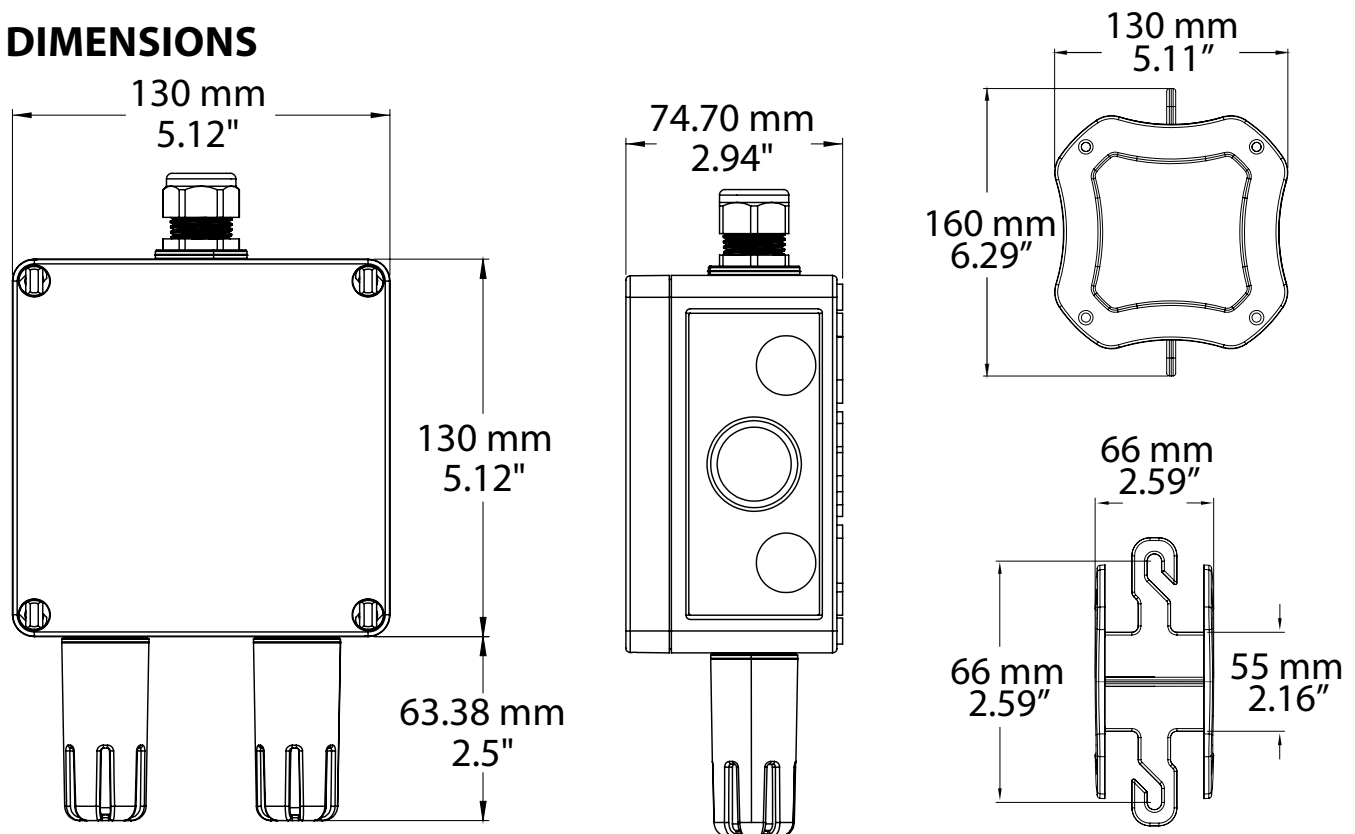



# SPECIFICATIONS:

## General Specifications

Power Supply .....	24 Vac/dc $\pm 20\%$ (non-isolated half-wave rectified)
Consumption .....	<b>Current:</b> 120 mA max @ 24 Vdc, 220 mA max @ 24 Vac <b>Voltage:</b> 80 mA max @ 24 Vdc, 130 mA max @ 24 Vac
Output Signals.....	4-20 mA active (sourcing) or 0-5 Vdc / 0-10 Vdc
Output Drive Capability .....	<b>Current:</b> 550 $\Omega$ maximum <b>Voltage:</b> 5 K $\Omega$ minimum
Protection Circuitry.....	Reverse voltage protected, overvoltage protected
Coverage Area .....	50' Radius from sensor. Suspended model: 7800 sqft, Wall mounted model: 3900 sqft
Operating Conditions .....	-10 to 50°C (14 to 122°F), 5 to 95 %RH non-condensing
Storage Conditions .....	-30 to 60°C (-22 to 140°F)
Wiring Connections.....	Screw terminal block (14 to 22 AWG)
Enclosure .....	IP65 (NEMA 4X) 130 mm W x 130 mm H x 75 mm D (5.12" x 5.12" x 2.95") <b>Cable Winder:</b> 130mm W x 160mm H x 66mm D (5.12" x 6.29" x 2.59")
Country of Origin.....	Canada

## LCD Display

Size.....	35 mm x 15 mm (1.4" x 0.6") alpha-numeric 2 line x 8 characters
Backlight.....	Enable or disable via menu

## Temperature Signal

Sensing Element.....	10K thermistor
Accuracy .....	$\pm 0.2^\circ\text{C}$ ( $\pm 0.4^\circ\text{F}$ )
Range.....	0 to 50°C (32 to 122°F)

## RH Signal

Sensor .....	Thermoset polymer based capacitive
Accuracy .....	$\pm 2\%$ RH
Range.....	0 to 100 %RH
Hysteresis .....	$\pm 1.5\%$ RH
Response Time .....	15 seconds typical
Stability .....	$\pm 1\%$ RH typical @ 50 %RH in 5 years

## CO<sub>2</sub> Signal

Measurement Type .....	Dual wavelength, non-dispersive infrared (NDIR), diffusion sampling
Measurement Range.....	0 to 2,000 ppm (0-5,000 ppm programmable)
Standard Accuracy .....	$\pm 50$ ppm + 3% of reading
Pressure Dependence.....	<1 % of reading / kPa
Response Time.....	2 minutes (T90)
Sensor Life Span.....	>10 years

## Relay Outputs (Optional)

Contact Ratings.....	Form C contact (N.O. + N.C.), 2 Amps @ 140 Vac, 2 Amps @ 30 Vdc
Relay Setpoint & Hysteresis .....	Programmable via menu
Relay Time Delay.....	Programmable via menu