

Outside Dewpoint Transmitter with Sun and Windshield

Installation Instructions

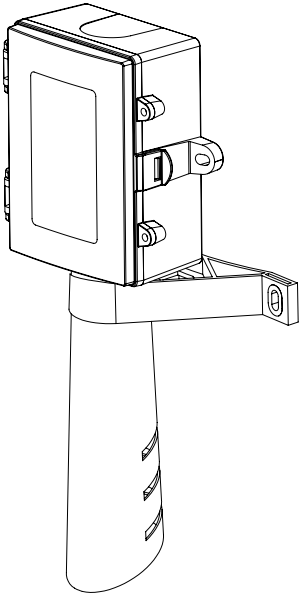

INTRODUCTION

The outside dewpoint transmitter is designed for use in environmental monitoring and control systems where high performance and stability are demanded. It's state-of-the-art design combines digital linearization and temperature compensation with a highly accurate and reliable thermoset polymer based capacitance humidity sensor and curve-matched NTC thermistor temperature sensor for reliability and accuracy in the most critical applications. A polycarbonate weatherproof enclosure is provided for ease of installation with an integrated sun and windshield.

BEFORE INSTALLATION

Read these instructions carefully before installing and commissioning the transmitter. Failure to follow these instructions may result in product damage. Do not use in an explosive or hazardous environment, with combustible or flammable gases, as a safety or emergency stop device or in any other application where failure of the product could result in personal injury. Take electrostatic discharge precautions during installation and do not exceed the device ratings.

MOUNTING

Select a suitable mounting spot on an exterior wall where the sensor is best protected from direct exposure to sunlight, wind, etc. preferably on a north facing wall. Do not mount the sensor near opening windows, supply/exhaust air louvres or other known air disturbances. Avoid areas where the sensor is exposed to vibrations or rapid temperature changes.

The enclosure provides a connection hole for 1/2" Conduit. Run a length of conduit through exterior wall and seal. Use 14-22 AWG shielded wiring for all connections and do not locate the device wires in the same conduit with wiring used to supply inductive loads such as motors. Make all connections in accordance with national and local codes.

The sensor installs directly on an exterior wall using the two integrated mounting holes are provided on the enclosure. Select the best mounting technique based on the exterior wall material. The 2 mounting holes will facilitate a #10 size screw (not supplied). The sensor shroud must be pointing down. See Figure 1.

The enclosure has a hinged cover with a latch. Open the cover by pulling slightly on the latch on the right side of the enclosure. At the same time pulling on the cover, as illustrated in Figure 2.

Feed conduit through the provided hole in the back of the enclosure and secure with a lock nut as shown in Figure 3. It is recommended that weatherproof conduit or cable gland fittings be used.

Make wiring connections as per the "Wiring" illustrations on Page 2.

Swing door closed until securely latched. For added security install the two supplied security screws as shown in Figure 4.

Figure 1

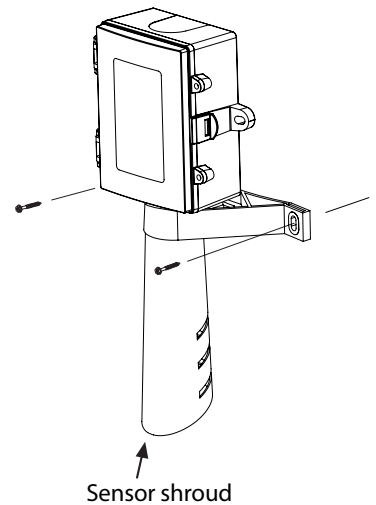

Figure 2

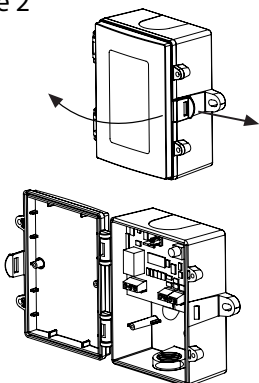

Figure 3

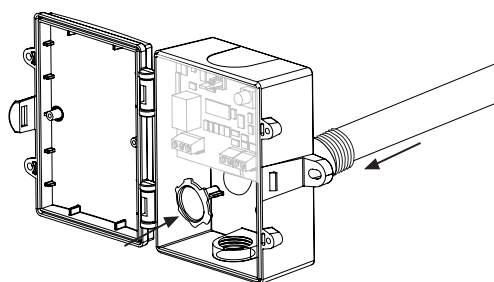
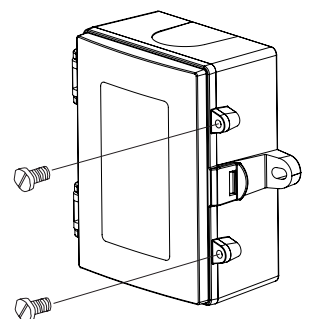

Figure 4



OUTPUT SELECTION

The device has selectable 4-20 mA, 0-5 Vdc or 0-10 Vdc Outputs. To select 4-20 mA, slide both output switches to CUR. To select 0-5 Vdc or 0-10 Vdc Outputs, slide both switches to VOLT. See Figure 5. When VOLT is selected, the default is 0-5 Vdc. It may be changed to 0-10 Vdc during set up.

WIRING

- Deactivate the 24 Vac/dc power supply until all connections are made to the device to prevent electrical shock or equipment damage.
- Follow proper electrostatic discharge (ESD) handling procedures when installing the device or equipment damage may occur.
- Use 22 AWG shielded wiring for all connections and do not locate the device wires in the same conduit with wiring used to supply inductive loads such as motors.
- Make all connections in accordance with national and local codes.

Connect the 24 Vac/dc power supply to the terminals labeled PWR (power) and COM (common) as shown in Figure 6. This device has a half-wave type power supply so use caution when wiring multiple devices so that the circuit ground point is the same on all devices and the controller. The device is reverse voltage protected and will not operate if connected backwards.

Figure 5

Current Output

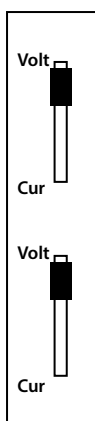

Voltage Output

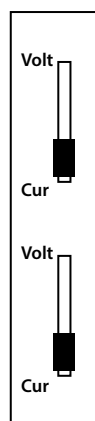

NOTE: Both switches need to be in the same mode

Figure 6

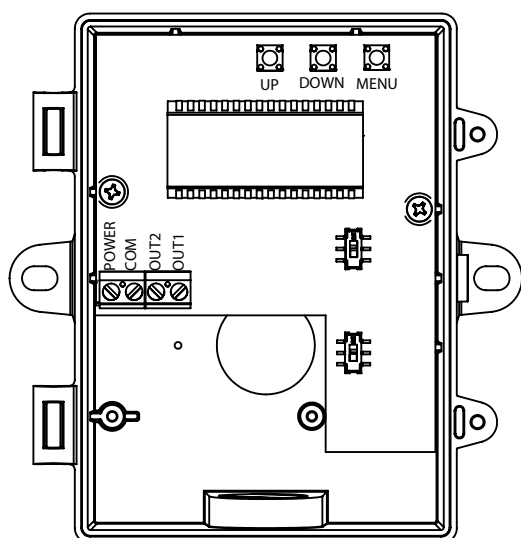
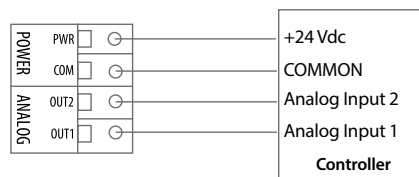
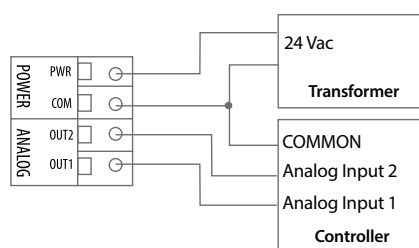

Figure 7

Wiring for all output signals with power from controller



Wiring for all output signals with external power supply or transformer



OPERATION

START-UP MODE

When the device is powered on, it will go through a brief start-up mode. The LCD will display a sequence of information depending on the model. At the end of the start-up sequence, normal operation will begin.

STEP 1. LCD TEST



All segments lit for 2 seconds.

STEP 2. SOFTWARE VERSION



Display Software Version for 2 seconds

STEP 3. MODEL



Displays the model type for 2 seconds.
(Volt or current depending on output selected)

STEP 4. DEFAULTS

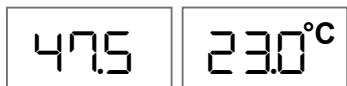

Displays Readings as per Channel 1 & 2 Defaults (RH & Temp).
Alternates 2 Second Intervals

NORMAL MODE

In normal operation the device:

- reads the temperature and RH sensors
- calculates values for dewpoint, wet bulb and enthalpy
- updates the LCD values
- updates the analog outputs
- monitors the menu key for activity

If the <MENU> key is pressed, normal operation is suspended while the menu functions are serviced. The program will automatically exit the menu after a period of inactivity.

MENU

The device has several parameters that can be configured locally via the User menu using the keypad and LCD. All parameters default to typical values but the installer may want to change some values. Any changes made are saved in non-volatile memory and are restored in case of a power loss. Only the menu items relevant to the device model will be shown. The menu can be accessed at any time after the start-up mode and if there is 5 minutes of inactivity the menu will close and normal operation will continue.

User Menu

To enter the menu, press and release the <MENU> key. This will enter the User menu step 1, pressing the <MENU> key a second time advances to step 2. Each press of the <MENU> key saves the current setting and advances the menu item. The <UP> and <DOWN> keys are used to make changes to program variables by scrolling through the available options. When a value is changed, use the <MENU> key to save it to memory and advance to the next menu item.

<MENU> Press and release to enter the User menu.

1. VOLTAGE OUTPUT

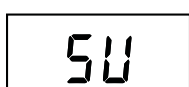

This setting only shows if the output jumpers were set to VOLT.
The default is 0-5 Vdc.
Press <UP> or <DOWN> to toggle the selection.



Press <MENU> to save and advance to next menu item

2. TEMPERATURE UNITS

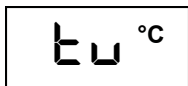

Press <UP> or <DOWN> to toggle the selection.
Press <MENU> to save and advance to next menu item

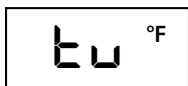

3. CHANNEL 1 SETTINGS



Default is Humidity.
Press <MENU> to save and advance directly to STEP 5 - Channel 2 Settings
Press <UP> or <DOWN> to scroll through additional parameter options

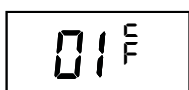

Temperature

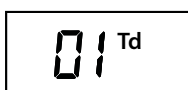

Dewpoint

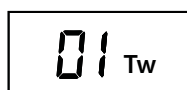

Wet Bulb

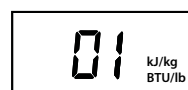

Enthalpy

Press <MENU> to select and save parameter and advance to range selection

4. CHANNEL 1 RANGE SELECTION

Only shows if parameter changed in previous step
Only ranges for selected parameter will be shown

4.1 TEMPERATURE RANGE



Default is -30 to 50 °C
Press <MENU> to save and advance directly to STEP 5 - Channel 2 Settings
Press <UP> or <DOWN> to scroll range options

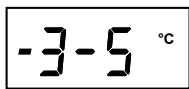

-30-50 °C

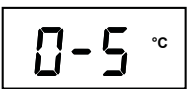

0-50 °C

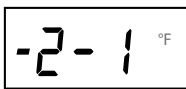

-22-122 °F

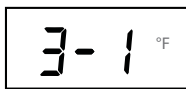

32-122 °F

Press <MENU> to select and save range and advance to STEP 5 - Channel 2 Settings

4.2 DEWPOINT RANGES

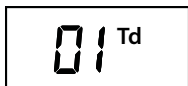

Default is -30 to 50 °C
Press <MENU> to save and advance directly to STEP 5 - Channel 2 Settings
Press <UP> or <DOWN> to scroll range options



-30-50 °C

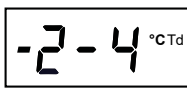

-20-40 °C



0-50 °C

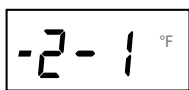

-22-122 °F

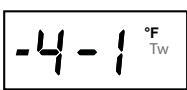

-4-104 °F

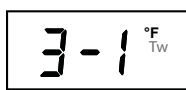

32-122 °F

Press <MENU> to select and save range and advance to STEP 5 - Channel 2 Settings

4.3 WET BULB RANGES

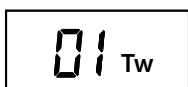

Default is -20 to 50 °C
Press <MENU> to save and advance directly to STEP 5 - Channel 2 Settings
Press <UP> or <DOWN> to scroll range options

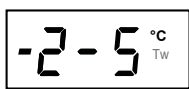

-20-50 °C

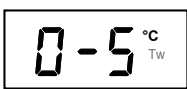

0-50 °C

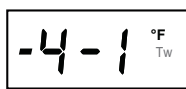

-4-122 °F

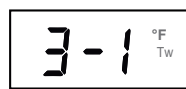

32-122 °F

Press <MENU> to select and save range and advance to STEP 4 - Channel 2 Settings

4.4 ENTHALPY RANGES

01 kJ/kg
BTU/lb

Default is 250 kJ/kg
Press <MENU> to save and advance directly to STEP 5 - Channel 2 Settings
Press <UP> or <DOWN> to scroll range options

250 kJ/kg

340 kJ/kg

107 BTU/lb

146 BTU/lb

Press <MENU> to select and save range and advance to STEP 4 - Channel 2 Settings

5. CHANNEL 2 SETTINGS

02 ^F

Default is Temperature.
Press <MENU> to save and advance directly to STEP 7 - LCD Display
Press <UP> or <DOWN> to scroll through additional parameter options

02H

Humidity

02^{Td}

Dewpoint

02^{Tw}

Wet Bulb

02 kJ/kg
BTU/lb

Enthalpy

Press <MENU> to select and save parameter and advance to range selection

6. CHANNEL 2 RANGE SELECTION

Only shows if parameter changed in previous step
Only ranges for selected parameter will be shown

6.1 TEMPERATURE

02 ^F

Default is -30 to 50 °C
Press <MENU> to save and advance directly to STEP 7 - LCD Display
Press <UP> or <DOWN> to scroll through options

-3-5 °C
-30-50 °C

0-5 °C
0-50 °C

-2-1 °F
-22-122 °F

3-1 °F
32-122 °F

Press <MENU> to select and save parameter and advance to range selection

6.2 HUMIDITY

02H

Press <MENU> to save and advance directly to STEP 7 - LCD Display

Press <MENU> to select and save parameter and advance to range selection

6.3 DEWPOINT

02^{Td}

Default is -30 to 50 °C
Press <MENU> to save and advance directly to STEP 7 - LCD Display
Press <UP> or <DOWN> to scroll through options

-3-5 °C_{Td}
-30-50 °C

-2-4 °C_{Td}
-20-40 °C

0-5 °C_{Td}
0-50 °C

-2-1 °F_{Td}
-22-122 °F

-4-1 °F_{Td}
-4-104 °F

3-1 °F_{Td}
32-122 °F

Press <MENU> to select and save parameter and advance to range selection

6.4 WET BULB

02_{TW}

Default is -20 to 50 °C

Press <MENU> to save and advance directly to STEP 7 - LCD Display

Press <UP> or <DOWN> to scroll through options

-2-5 °C
TW
-20-50 °C

0-5 °C
TW
0-50 °C

-4-1 °F
TW
-4-122 °F

3-1 °F
TW
32-122 °F

Press <MENU> to select and save parameter and advance to range selection

6.5 ENTHALPY

02
kJ/kg
BTU/lb

Default is 250 KJ/KG

Press <MENU> to save and advance directly to STEP 7 - LCD Display

Press <UP> or <DOWN> to scroll through options

250 kJ/kg

340 kJ/kg

107 BTU/lb

146 BTU/lb

Press <MENU> to select and save parameter and advance to next menu item

7. LCD DISPLAY

L 12

Alternate Channel 1 and Channel 2

Press <UP> or <DOWN> to scroll through options

L 1

L 2

Press <MENU> to save and advance to next menu item

8. TEMPERATURE OFFSET

t 0.0 °C

Default = 0 °C or 0 °F

Press <UP> or <DOWN> to scroll through options

-t 5.0 °C
-5.0 °C

t 5.0 °C
5.0 °C

-t 10 °F
-10 °F

t 10 °F
10 °F

Press <MENU> to save and advance to next menu item

9. HUMIDITY OFFSET

00H

Default is 0% RH

Press <UP> or <DOWN> to set offset

Press <MENU> to save and advance to next menu item

10. ALTITUDE

A0

Default is 0 ft

This item is to set the local altitude to increase calculation accuracy.

Use <UP> or <DOWN> to change from A 0 to A60.

Resolution is 100 ft steps.

Press <MENU> to save and advance to next menu item

SPECIFICATIONS:

Sensor Type

RH Sensor Thermoset Polymer based capacitive
Temperature Sensor NTC Thermistor

Measurement Range:

Relative Humidity 0 - 100 %RH
Dry Bulb Temperature -30 to 50 °C (-22 to 122 °F)

Calculated Values:

Dewpoint Temperature -30 to 50 °C (-22 to 122 °F)
Wet Bulb Temperature -30 to 50 °C (-22 to 122 °F)
Enthalpy 0 to 340 kJ/kg (0 to 146 BTU/lb)

Accuracy:

Relative Humidity (RH) ± 2% RH, 10 to 90 %RH @ 25 °C
Dry Bulb Temp.(T) ± 0.2 °C (± 0.4 °F) / 0 to 50 °C (32 to 122 °F)
Dewpoint Temp. (Td) ± 1.0 °C (± 1.8 °F) @ 40 %RH / 25 °C
Wet Bulb Temp.(Tw) ± 1.0 °C (± 1.8 °F) @ 50 %RH / 25 °C
Enthalpy (En) ± 2 kJ/kg (± 1 BTU/lb) @ 50 %RH / 25 °C

Output:

Signals (2X) 4 - 20 mA or 0-5/0-10 Vdc
Relative Humidity 0 to 100% RH
Dry Bulb Temperature: T Range 1: -30 to 50°C (-22 to 122°F)
T Range 2: 0 to 50°C (32 to 122°F)
Dewpoint Temperature: Td Range 1: -30 to 50°C (-22 to 122°F)
Td Range 2: -20 to 40°C (-4 to 104°F)
Td Range 3: 0 to 50°C (32 to 122°F)
Wet Bulb Temperature: Tw Range 1: -20 to 50°C (-4 to 122°F)
Tw Range 2: 0 to 50°C (32 to 122°F)
Enthalpy: En Range 1: 0 to 340 kJ/kg (0 to 146 BTU/lb)
En Range 2: 0 to 250 kJ/kg (0 to 107 BTU/lb)
Output: 500 Ω max for current (@ 24 Vdc), 10 KΩ min for voltage
Power Supply 20 to 27 Vdc, 16 to 27 Vac (non-isolated half-wave rectified)
Current model 50 mA max @ 24 Vdc, 1.5 VA max @ 24 Vac
Voltage model 30 mA max @ 24 Vdc, 1 VA max @ 24 Vac
Operating Conditions -30 to 50 °C (-22 – 122 °F), 0 to 95 %RH non-condensing
Storage Conditions -40 to 70 °C (-40 – 158 °F), 0 to 95 %RH non-condensing
Wiring Connections 14 to 22 AWG terminal block

Enclosure:

Dimensions 112.5W x 116.5H x 53.7D mm (4.43W x 4.585H x 2.115D in)
Material Grey polycarbonate with gasket, UL94-V0
Ratings IP65 (NEMA 4X)

Probe 25.4 mm (1.00") L x 25.4 mm (1.00") D, PVC hub with mesh filter

LCD Display Values:

Temperature -30.0 to 50.0 °C (0.5 °C resolution) or -22 to 122 °F (1 °F resolution)
Relative Humidity 0 to 100% RH (1% RH resolution)
Dewpoint -30.0 to 50.0 °C Td (0.5 °C resolution) or -22 to 122 °F Td (1 °F resolution)
Wet Bulb -20.0 to 50.0 °C Tw (0.5 °C resolution) or -4 to 122 °F Tw (1 °F resolution)
Enthalpy 0 to 340 kJ/kg (1 kJ/kg resolution) or 0 to 146 BTU/lb (1 BTU/lb resolution)

Standards:

Approvals CE, RoHS
Country of Origin Canada

DIMENSIONS

