

Mini Current Sensor

Installation Instructions

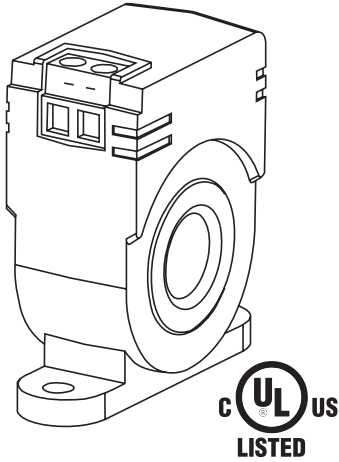

INTRODUCTION

The series of current sensors monitor line current for electrical loads such as pumps, conveyors, machine tools or fans and output an analog 4-20 mA signal to represent the load current. They are typically used to monitor motor operation and can be used to determine motor failure, belt loss, machine feed rates or tool wear.

The sensors are loop powered and require an external 15-30 Vdc power supply. The power supply must be $10 \text{ Vdc} + (R_{\text{load}} \times 20 \text{ mA})$ where R_{load} is the input resistance of the device measuring the signal. So if R_{load} is 250Ω the minimum power supply is 15 Vdc. The measured AC line current can be calculated as $I_{\text{line}} = (I_{\text{loop}} - 4 \text{ mA}) \times I_{\text{range}} / 16$ where I_{range} is 10, 20 or 50 Amps.

The output signal is limited to $< 23 \text{ mA}$, is reverse voltage protected and is factory calibrated to $< \pm 1\% \text{ FSO}$.

WARNING

- **Electric shock hazard, use caution**
- Disconnect and lock out power before installation
- Follow national and local electrical codes
- Read and understand these instructions before installing
- Installation only by qualified electrical personnel
- Do not rely on this device to indicate line power
- Only install this device on insulated conductors
- Only install on 600 Vac maximum conductors
- Do not use this device for life-safety applications
- Do not install in hazardous or classified locations
- Install this product in a suitable electrical enclosure
- **Failure to follow these instructions will result in death or serious injury**

INSTALLATION

Read all warnings before beginning installation of this device. Ensure the selected device has the correct ratings for your application. **Disconnect and lock out power.** Make all connections in accordance with national and local codes.

The base of the device has an integrated mounting tabs to allow the use of screws to mount to a surface.

To mount the device to a flat surface, select an area that will allow side and top access to the wire device. If pre-drilling is required, use the device to mark the holes on the mounting surface. The mounting holes in the base will accommodate up to a #10 size screw (not supplied). See Figure 1.

Place the monitored conductor (must be insulated) through the sensor hole and reconnect. Observe polarity and wire the output to the controller, see Figure 2. Use 14 to 22 AWG shielded wiring for all connections. Ensure the controller scale matches the sensed range. See specifications for model ranges.

Reconnect the power.

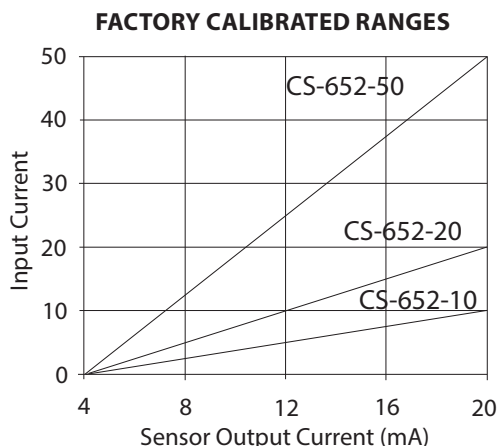

Figure 1

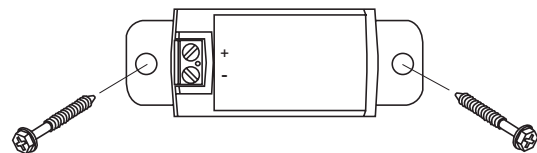
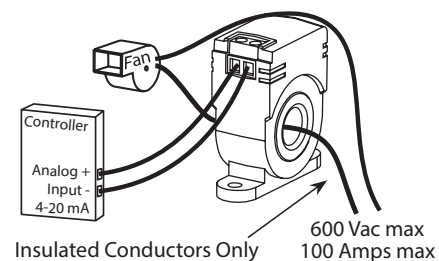

Figure 2



CALIBRATION

All models are factory calibrated to operate within $\pm 1\%$ of FSO. If field calibration is required or a custom measurement range is desired, simply peel back the top label to expose the calibration pots. The adjustment pots set the current zero (4 mA) and span (20 mA) of the device and may be adjusted by about $\pm 20\%$ of FSO. Repeat each adjustment until both are acceptable.

APPLICATIONS

For applications with load currents exceeding the sensor current range use an external CT to reduce the current to an acceptable value. For example, to measure a 200 Amp load current, use a 200A:5A CT and wrap the CT secondary through the 10 Amp model twice so the sensor output will be 4-20 mA = 0-200 Amps.

For applications with very small load currents (such as less than 1 Amp), wrap the monitored conductor through the sensor aperture several times to increase the current measured by the sensor. For example, to measure 0-2 Amps with a 10 Amp model, wrap the conductor through the sensor aperture 5 times so the sensor output will be 4-20 mA = 0-2 Amps.

For any application using an external CT or with multiple wraps, ensure the controller is scaled accordingly to obtain the correct readings.

For any application with multiple wraps, note that the device maximum current rating must be divided by the number of wraps. For example, with one wrap the maximum current is 100 Amps, with 5 wraps the maximum current is $100/5 = 20$ Amps. Ensure the load current is < 20 Amps or the device may overheat and be damaged.

SPECIFICATIONS

Measurement Range.....	10/20/50 Amps (select model)
Maximum Input Current.....	100 Amps continuous
Accuracy.....	$\pm 1\%$ FSO
Sensor Power.....	15 to 30 Vdc (loop powered)
Output Signal.....	4-20 mA
Insulation Class.....	600 Vac, insulated conductors
Frequency.....	50/60 Hz
Response Time.....	200 mS (0-90%)
Output Load.....	250 Ω typical
Maximum Load.....	$> 600\Omega$ at 24 Vdc
Operating Temperature.....	-15 to 60°C (5 to 140°F)
Operating Humidity.....	5 to 90 %RH, non-condensing
Terminal Block.....	14 to 22 AWG
Dimensions.....	48mm W x 49mm H x 21mm D (1.9" x 1.93" x 0.83")
Sensor Aperture.....	11.4mm (0.45")
Enclosure.....	ABS/PC, UL94 V-0
Manufacturing.....	ISO 9001 Certified
Agency Approvals.....	cULus Listed

DIMENSIONS

