

# Current Sensor

## Installation Instructions

### INTRODUCTION

The current sensor monitors line current for electrical loads such as pumps, conveyors, machine tools or fans and provides a 0-10 Vdc analog output to represent the load current.

The sensor requires no external power supply as it is totally powered by induction from the AC line being monitored. The output signal is factory calibrated with either single or multiple range products available.

The sensors are typically used to monitor AC motor operation and can be used to determine motor failure, belt loss, machine feed rates or tool wear.

### \*WARNING\*

- **Electric shock hazard, use caution**
- Disconnect and lock out power before installation
- Follow national and local electrical codes
- Read and understand these instructions before installing
- Installation only by qualified electrical personnel
- Do not rely on this device to indicate line power
- Only install this device on insulated conductors
- Only install on 600 Vac maximum conductors
- Do not use this device for life-safety applications
- Do not install in hazardous or classified locations
- Install this product in a suitable electrical enclosure
- **Failure to follow these instructions will result in death or serious injury**

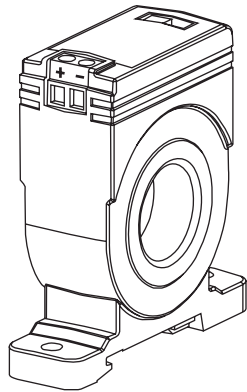

### INSTALLATION

**Read all warnings before beginning installation of this device.** Ensure the selected device has the correct ratings for your application. Set the range switch to the desired range. See Figure 1. **Disconnect and lock out power.** Mount the sensor with two screws through the base or snap onto a standard DIN mounting rail.

The base has an integrated mounting tab to allow either screw mount to a surface or spring mount to a DIN rail.

To mount the device to a flat surface, select an area that will allow side and top access to wire device. Slide the mounting tab in so that both the mounting holes are accessible. If pre-drilling is required then the device may be used to mark holes on the mounting surface. The mounting holes in the base will accommodate up to a #10 size screw. (not supplied). See Figure 3.

For DIN rail mounting, first slide the mounting tab to its outer position and then hook the fixed end to the DIN rail and finally the tab end may be snapped onto the rail. The tab may be pulled out slightly to allow easier mounting or to remove the device from the rail. See Figure 4.

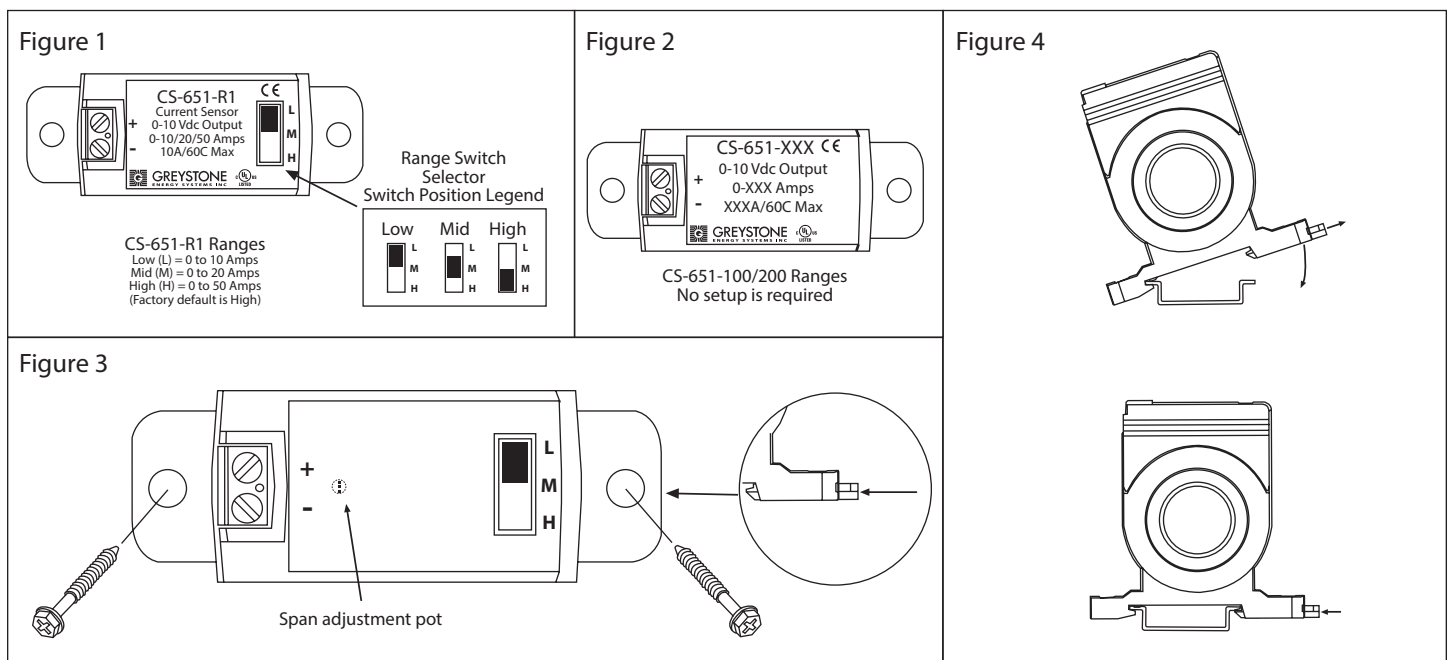

Place the monitored conductor (must be insulated) through the sensor hole and reconnect. See Figure 5. Observe polarity and wire the output to the controller. Use 14-22 AWG shielded wiring for all connections and do not locate the device within the same conduit with wiring used to supply inductive loads such as motors. Make all connections in accordance with national and local codes. See Figure 6. Ensure the controller scale matches the sensed range. See specifications for model ranges. Reconnect the power.

## APPLICATION

The current sensors come factory calibrated, but if field calibration is required or a custom measurement range is desired, simply peel back the top label to expose the calibration pot. See Figure 3. The adjustment pot sets the current span of the device and may be adjusted by about  $\pm 20\%$  of FSO.

For applications with load currents exceeding the sensor current ranges, use an external CT to reduce the current to an acceptable value. For example, to measure a 500 Amp load current, use a 500A:5A CT and wrap the CT secondary through the CS-651-R1 two times on the 10 Amp range so the sensor output will be 0-10 Vdc = 0-500 Amps.

For applications with small load currents (such as less than 2 Amps), wrap the monitored conductor through the sensor aperture several times to increase the current measured by the sensor. For example, to measure 0-2 Amps with a CS-651-R1, wrap the conductor through the sensor aperture 5 times on the 10 Amp range so the sensor output will be 0-10 Vdc = 0-2 Amps.

For external CT or multiple wrap applications, ensure the controller is scaled accordingly to obtain correct readings.

For any application with multiple wraps, note that the CS-651 maximum current rating must be divided by the number of wraps. For example, with one wrap the maximum current is 100 Amps, with 5 wraps the maximum current is  $100/5 = 20$  Amps. Ensure the load current is  $< 20$  Amps or the device may overheat and be damaged.

Note these may not be practical applications, select the correct device for the current range required.

## SPECIFICATIONS

Measurement Range.....	<b>CS-651-R1:</b> 0-10/20/50 Amps <b>CS-651-100:</b> 0-100 Amps <b>CS-651-200:</b> 0-200 Amps
Maximum Input Current.....	<b>CS-651-R1:</b> 100 Amps Continuous <b>CS-651-100:</b> 150 Amps Continuous <b>CS-651-200:</b> 225 Amps Continuous
Accuracy .....	<b>CS-651-R1:</b> $\pm 2\%$ FSO (5 to 100% of range) <b>CS-651-100/200:</b> $\pm 1\%$ FSO (5 to 100% of range)
Signal Output.....	0-10 Vdc
Sensor Power.....	Self-powered
Insulation Class.....	600 Vac, insulated conductors
Frequency.....	50/60 Hz
Response Time.....	200 mS typical, 0 to 90%
Output Load.....	1 M $\Omega$ typical
Loading Error.....	Add 5% error with 100K $\Omega$
Operating Temperature.....	-15 to 60°C (5 to 140°F)
Operating Humidity.....	5 to 90 %RH non-condensing
Terminal Block.....	14 to 22 AWG
Dimensions.....	67 x 68.6 x 24.1 mm (2.65 x 2.7 x 0.95 in)
Sensor Aperture.....	20.3 mm (0.8 in)
Enclosure Material.....	ABS/PC, UL94 V-0
Agency Approvals.....	cULus Listed
Country of Origin.....	Canada

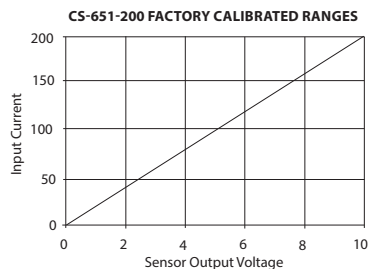
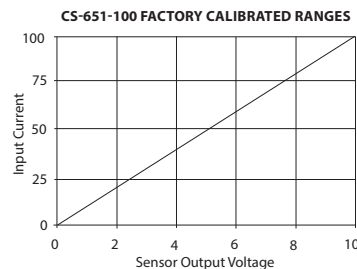
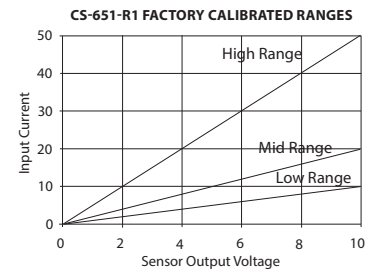
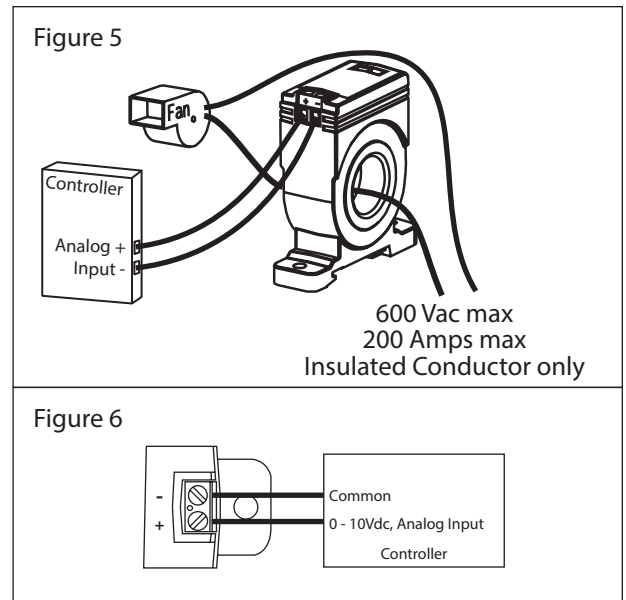

## DIMENSIONS

