

CLEANROOM MONITOR

Installation Instructions

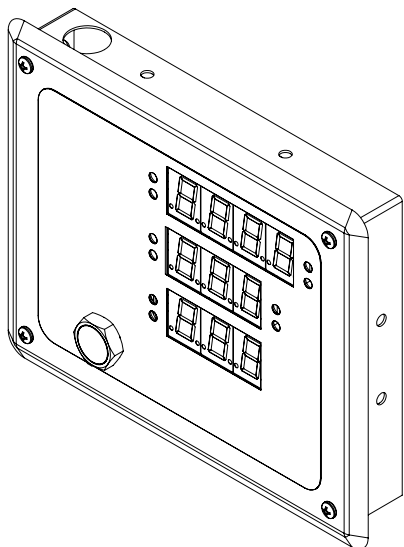

INTRODUCTION

The CR3 Series Cleanroom Monitor was developed specifically to allow for monitoring of confined spaces with accuracy and reliability.

The CR3A features integrated sensors for monitoring temperature, humidity and pressure within the space it's mounted in. The CR3A is available with output signal of either Analog, BACnet[®] or Modbus. Standard features include adjustable alarm relays for each parameter, audible/visual alarms, and large LED displays.

The CR3A is housed in a flush fitting stainless-steel front plate that enables the user to wipe down the unit when necessary.

BEFORE INSTALLATION

Read these instructions carefully before installing and commissioning the cleanroom monitor. Failure to follow these instructions may result in product damage. Do not use in an explosive or hazardous environment, with combustible or flammable gases, as a safety or emergency stop device or in any other application where failure of the product could result in personal injury. Take electrostatic discharge precautions during installation and do not exceed the device ratings.

MOUNTING

STEP 1 - As illustrated in Figure 1, unscrew four screws from faceplate, set screws aside, and remove faceplate from mounting bracket.

Cut hole in wall 210 mm x 167 mm high. Ensure unit can be secured to wall stud or equivalent on at least two sides.

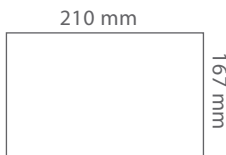

STEP 2 - As illustrated in Figure 2, feed wires through mounting bracket and conduit connector/cable gland and secure.

STEP 3 - As illustrated in Figure 3, insert mounting bracket into hole in wall.

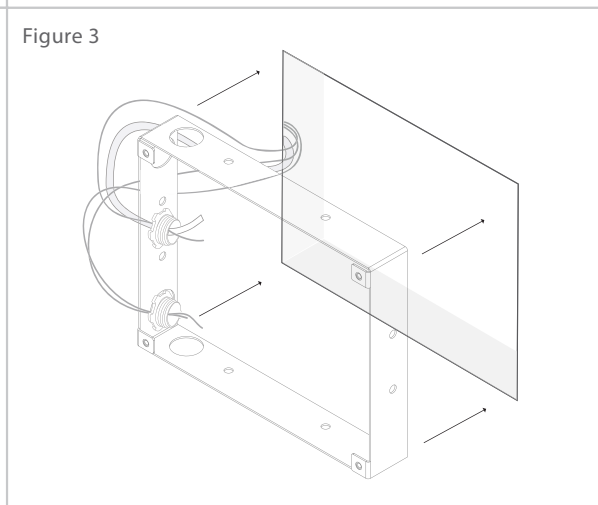
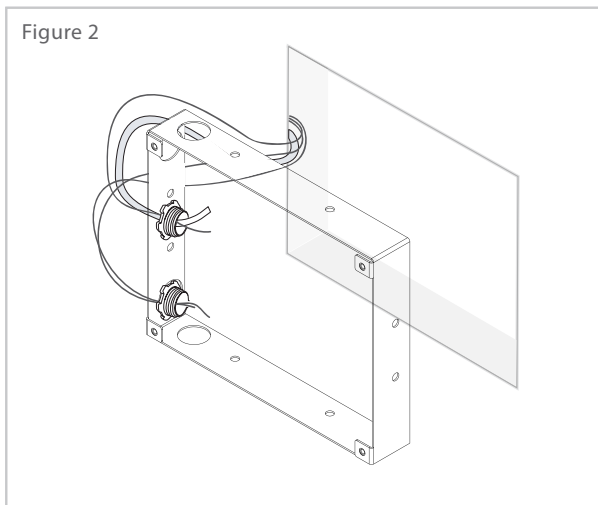
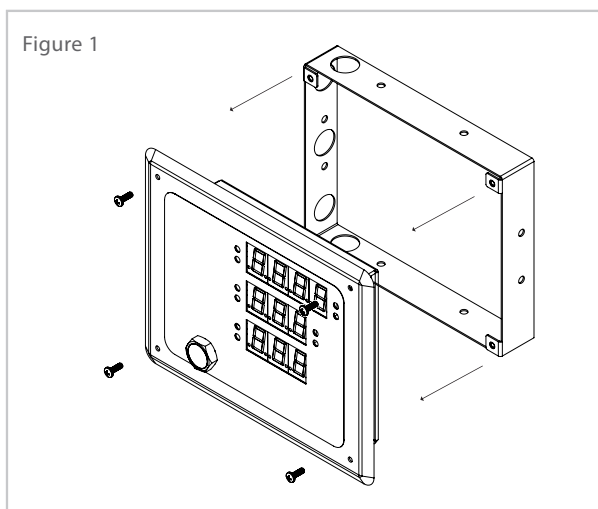

Figure 4

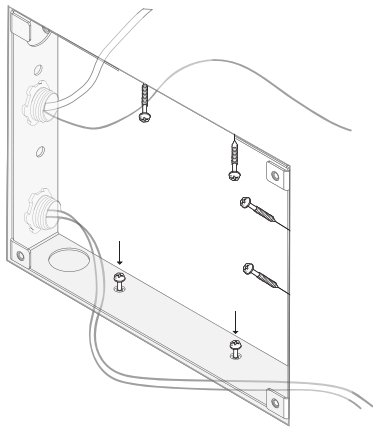

Figure 5

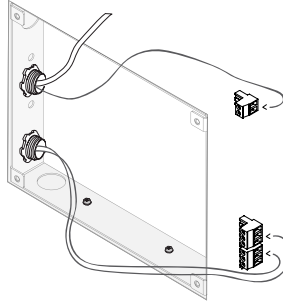

Figure 6

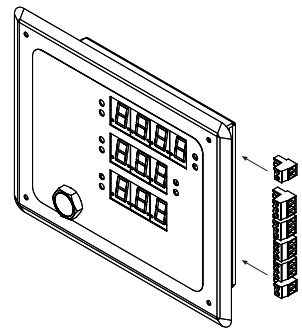

Figure 7

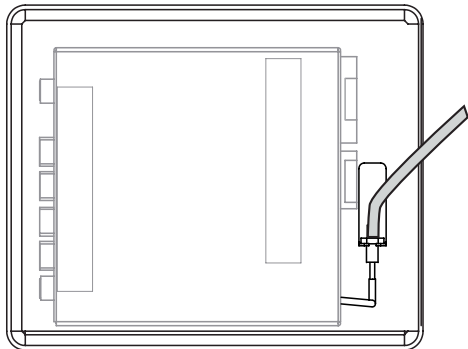
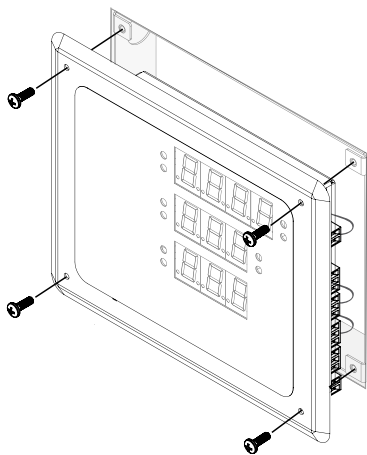

Figure 8



STEP 4 - As illustrated in Figure 4, insert screws (not included) to secure mounting bracket to studs. (Minimum #8 screw)

STEP 5 - Remove connectors from packaging box. As illustrated in Figure 5, connect wires to wiring terminals. Refer to wiring section for terminal identification.

STEP 6 - Match wiring terminals to the labels on the back cover and re-insert the wiring terminals into the unit. As illustrated in figure 6.

STEP 7 - As illustrated in Figure 7, run poly tubing onto the pressure port that is mounted on the rear of faceplate. Connect poly tube to customer supplied pressure vent (i.e. Greystone RPV).

STEP 8 - As illustrated in Figure 8, secure faceplate to mounting bracket with supplied screws. Route wires and tubing to prevent pinching when installing unit into wall mounting bracket.

WIRING

- Deactivate the 24 Vac/dc power supply until all connections are made to the device to prevent electrical shock or equipment damage.
- Follow proper electrostatic discharge (ESD) handling procedures when installing the device or equipment damage may occur.
- Use 22 AWG wiring for all connections and do not locate the device wires in the same conduit with wiring used to supply inductive loads such as motors.
- Make all connections in accordance with national and local codes.

Connect the 24 Vac/dc power supply to the terminals labeled PWR +(power) and - (common) as shown in Figure 9. This device has a half-wave type power supply so use caution when wiring multiple devices so that the circuit ground point is the same on all devices and the controller. Use caution if 24 Vac power is used and one side of the transformer is earth-grounded. In general, the transformer should NOT be connected to earth ground when using devices with RS-485 network connections. The device is reverse voltage protected and will not operate if connected backwards. Figure 11 shows network connections. For end of Line (EOL) device place termination resistor jumper in ON position, for all other devices, place jumper in OFF position.

Figure 9 REAR VIEW

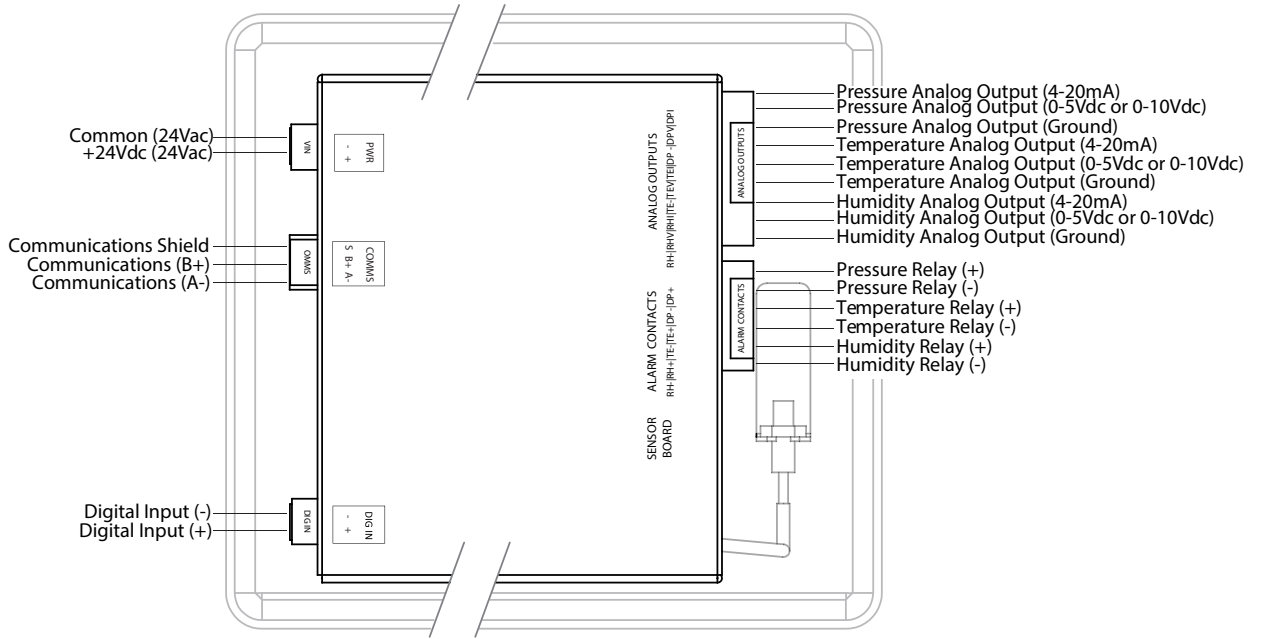

Figure 11 COMMUNICATION WIRING

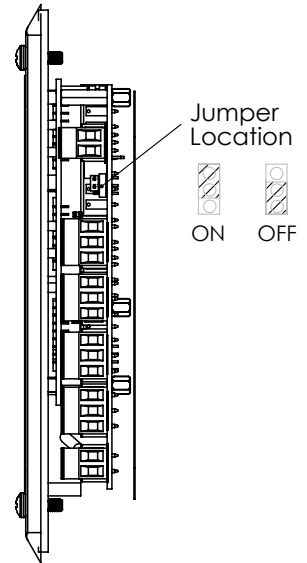
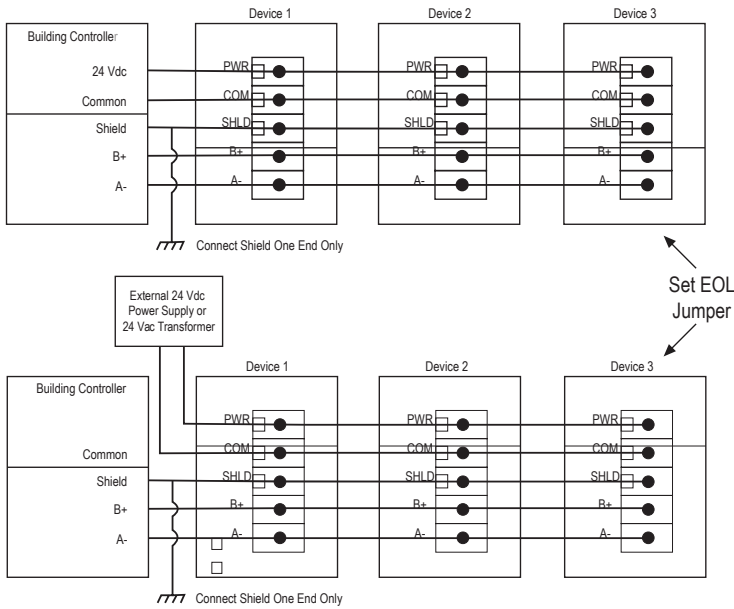
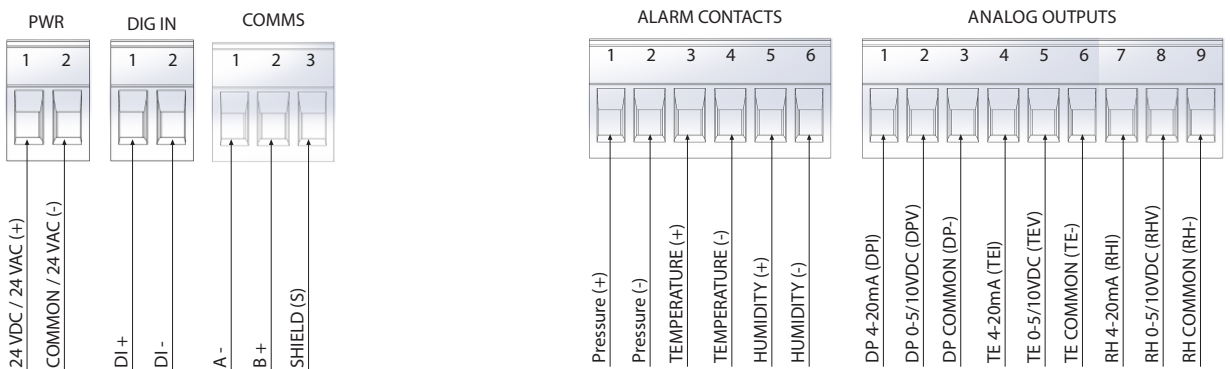

Figure 12 CONNECTORS (Front view, screw on top)



ALARM RELAYS

The device has three alarm relay outputs. The outputs are Normally Open and will close when an alarm event occurs. The alarm outputs are assigned to TEMP, RH and DP.

Each alarm can be set to operate as a low alarm, a high alarm, both low and high alarms or be disabled.

For example:

The TEMP Alarm output can be configured as a high alarm by setting TEMP Alarm Operation to High Alarm. In this case the alarm condition will be set when the temperature exceeds the TEMP Alarm High Setpoint. Note that alarm hysteresis and alarm on delay will also come into play, described below.

The RH Alarm output can be configured as both low and high alarms by setting RH Alarm Operation to Both. In this case the alarm condition will be set when the RH goes above the RH Alarm High Setpoint or below the RH Alarm Low Setpoint.

If any ALARM OPERATION is set to Disable, then that alarm will have no function and the setpoints will be hidden on the menu.

Each alarm has a hysteresis value and an on delay time associated with it. For high alarms, the alarm condition is set when the input value exceeds the high setpoint and it is reset when the input value goes below the setpoint – hysteresis value. For example, if the TEMP ALARM HIGH SETPOINT = 25.0 °C and TEMP ALARM HYSTERESIS = 0.5 °C, then the alarm condition will set at 25.0 °C and reset at 24.5 °C.

The hysteresis is opposite for TEMP ALARM LOW SETPOINT. The alarm condition will set when the input value falls below TEMP ALARM LOW SETPOINT and will reset when the input goes above TEMP ALARM LOW SETPOINT + HYSTERESIS.

Each alarm also has a configurable on delay. When an alarm condition is set a timer is started and the actual alarm will not get set until the ALARM ON DELAY time has expired. If the alarm condition gets reset before the time expires, then no alarm is generated.

All three alarm relays operate as self-resetting and non-latching. The input signal must return to non-alarm condition before the alarm relay returns to the NO state.

ALARM SETPOINTS

Each process variable (TEMP, RH and DP) has both a high and low alarm setpoint. If the alarms are enabled and the setpoint is not locked, then the user can change the setpoint values within a range.

ALARM LEDS

The TEMP, RH and DP each have a low and high alarm condition. When any alarm condition is set the corresponding front panel LED will flash. The alarm LEDs mimic the alarm relays. If any alarm is disabled, then the LED will be disabled also.

BUZZER ALARM

The buzzer alarm can be assigned to any of the TEMP, RH or DP alarms specifically, or it can be assigned to all of them. It can be disabled via BUZZER ASSIGNMENT.

If assigned, the buzzer will activate whenever the associated alarm(s) are triggered.

The buzzer reset can be configured as either manual only or automatic reset with BUZZER RESET.

In manual mode the buzzer can only be silenced by:

- removing the alarm condition or
- by pressing the front panel <SILENCE> key

In automatic reset mode the buzzer can be silenced by:

- removing the alarm condition or
- by pressing the front panel <SILENCE> key or
- automatically when the BUZZER AUTO RESET TIME expires

The buzzer is reset or silenced as described above but the alarm condition will continue to be set, this function only silences the buzzer. If the alarm condition is reset and then set again, the buzzer will activate again. The buzzer provides a “beeping” or “chirping” sound, not a continuous tone.

DIGITAL INPUT

The digital input signal allows detection of a dry-contact type input change. This input could be connected to a door switch, remote nurse station silence switch, occupancy sensor etc.

The actual program function of the DI can be set with DIGITAL INPUT FUNCTION. The input may be disabled to have no internal program function, or it may be used as a remote alarm silence with the same function as the front panel <SILENCE> key, or it may be used as a door freeze function.

The door freeze function can be used to prevent alarms and fast ramps of the analog output when a door is opened. In this mode, if a digital input from a door switch is detected, then the operation of the device freezes. This means that no alarms will be generated and the analog outputs are held at the last value before the door open occurred. The device will sit in this state until the door closes again. There is a small delay of 10 seconds to allow the room to stabilize again after the door is closed.

RS-485 NETWORK

The network connection is a standard feature on the product and is necessary to fully configure the device. The unit will have either BACnet® or Modbus protocol implemented.

ANALOG OUTPUTS

There are three analog output signals to represent TEMP, RH and DP. Select desired output via installer menu for current (4-20 mA) or voltage output signals. If the analog outputs are set for voltage output, then the signal type can be set to either 0-5 Vdc or 0-10 Vdc via the Installer Menu. All outputs will set for the same type.

The direction of the analog output signals may be reversed by using the TEMP OUT DIRECTION (for example) Installer Menu item. This means that the output signal will be 5-0 V or 20-4 mA instead of 0-5 V or 4-20 mA.

MIN MAX VALUES

The program maintains the minimum and maximum value of each sensor value. The values may be displayed via the User Menu and may also be reset via the User Menu.

MISCELLANEOUS

The displays (and associated alarm LEDs) for each process variable may be turned off if necessary using the Installer Menu items such as TEMP DISPLAY.

Display brightness may be changed from high to low using DISPLAY BRIGHTNESS via the User Menu.

OPERATION

Start up





When power is first applied to the device, a specific sequence of events occurs to test the displays plus indicate certain parameters.

The sequence is as follows:

- Test all LEDs – all LEDs light for 2 seconds and then turn off
- Test all display segments – all display segments light for 2 seconds and then turn off
- Display version # - display "1.00" on one of the displays for 2 seconds
- Display selected protocol – display "Prot bAC" or "Prot bUS"
- Display address - display "Addr 003"
- Display baud rate - display "bAUd 9600"
- Buzzer beeps 2 times
- Begin normal operation

FRONT PANEL KEYS

There are 4 front panel buttons:

-  <UP> Used to increase parameter values within a menu.
-  <DOWN> Used to decrease parameter values within a menu.
-  <MENU> In normal operation, pressing this button accesses the User Menu and then is used to step through the menu items. The button is disabled if USER MENU LOCK is set.
-  <SILENCE> Used to silence the buzzer if it is active.

INSTALLER MENU

The Installer Menu is accessed by pressing and pushing both the <UP> and <DOWN> buttons together in normal operation at the same time for 5 seconds. This menu is used in the field to configure parameters such as the communication protocol, device address, analog output type, etc. The Installer Menu may be locked so it cannot be accessed in the field, or unlocked via BACnet®, Modbus or the Factory menu if necessary using INSTALLER MENU LOCK.

If the Installer Menu is unlocked, then the following parameters are available to be changed. Some items will not be available depending on other settings.

NOTE : To change a previous setting, return to the initial install menu.

1. Baud Rate

b.A.U.d.

9

9 600, 19 200, 38 400,
57 600, 76 800, 115 200

6.00

A.d.d.r.

2. Address

b.A.c.

0-127 for BACnet® Addr
1-255 for Modbus 0 to 255

003

INSTALLER MENU (Continued)

Only if **Modbus** selected

3. Parity
(No Parity, Odd or Even)

P A r . .

n o n . .

. . .

non, odd, E (Default = non)

4. Stop Bits

S t o p . .

1 . .

. . .

1 or 2 (Default = 1)

5. CRC

A 0 0 1 . . .

c r c . .

. . .

A001, 1021, 8005, 8408 (Default = A001)

6. Delay

d e l a y . .

. . 0 . .

. . .

0, 50, 150, 200, 250, 300, 350 (Default = 0)

7. Analog Output Type
(Current or Voltage)

c u r r . .

. . .

v o l t . .

curr, volt (Default = curr)

8. Volt Output Scale
(Only if voltage selected)

v o l t . .

s c a l e . .

5 . .

5 or 10 (Default = 5)

Only if **AO OVERRIDE** set via comms

9. AO TEMP Override

A o 1 . .

t e m p . .

. . 0 . .

0 to 100 (Default = 0)

10. AO RH Override

A o 2 . .

r h . .

. . 0 . .

0 to 100 (Default = 0)

11. AO DP Override

A o 3 . .

d p . .

. . 0 . .

0 to 100 (Default = 0)

INSTALLER MENU (Continued)

12. DP Auto Zero

(Only if DP within 10% range)

dP

0

cal

cal, lo, hi, pas (Default = cal)

13. User Menu

(Lock / Unlock)

USER

un

Loc

unLoc, Loc (Default = unLoc)

USER MENU

The User Menu is accessed by pressing the <MENU> key. This menu is used in the field to configure parameters such as alarm setpoints. The User Menu may be locked so it cannot be accessed in the field, but can be unlocked via BACnet®, Modbus or the Installer menu if necessary using USER MENU LOCK.

If the User Menu is unlocked, then the following parameters are available to be changed.

If SETPOINT LOCK is set, then the setpoints can be viewed but not changed.

1. Temperature Units

unit

EE

C

C F (Default = C)

2. Pressure Units

(Pascal or mmWc)

unit

dP

PA

PA, StA (Default = PA)

3. Display Brightness

display

brt

hi

hi, Lo (Default = hi)

4. TEMP Alarm Low Setpoint

TEMP

Lo

10

(Resolution is 1° via the menu)

(0-26°C or 32 to 79°F)

5. TEMP Alarm High Setpoint

TEMP

hi

22

(Resolution is 1° via the menu)

(4-30°C or 39 to 86°F)

6. RH Alarm Low Setpoint

RH

Lo

30

(Resolution is 1 %RH via the menu)

5 to 60% RH

7. RH Alarm High Setpoint

RH

hi

65

(Resolution is 1 %RH via the menu)

40 to 90% RH

8. DP Alarm Low Setpoint

When Pa units selected, setpoint value displayed has been divided by 10.

d.P.L.P.

(Resolution is 10 Pa or 1 mmWc via menu)

L.0.

-250 to 0 Pa (-25 to 0 mmWc) Pressure Range 1

.0.

-500 to 0 Pa (-50 to 0 mmWc) Pressure Range 2

9. DP Alarm High Setpoint

When Pa units selected, setpoint value displayed has been divided by 10.

d.P.H.P.

(Resolution is 10 Pa or 1 mmWc via menu)

H.1.

-150 to 200 Pa (-15 to 20 mmWc) Pressure Range 1

.20.

-400 to 400 Pa (-40 to 40 mmWc) Pressure Range 2

10. TEMP Minimum Value

T.E.L.O.

(Resolution is 0.1°C)

. . .

(displays minimum recorded temperature)

24.9

11. TEMP Maximum Value

T.E.H.I.

(Resolution is 0.1°C)

. . .

(displays maximum recorded temperature)

25.2

12. RH Minimum Value

r.h.L.o.

(Resolution is 1%RH)

. . .

(displays minimum recorded RH)

12.7

13. RH Maximum Value

r.h.H.I.

(Resolution is 1%RH)

. . .

(displays maximum recorded RH)

13.1

14. DP Minimum Value

d.P.L.o.

(Resolution is 1 Pa or 1 mmWc)

. . .

(displays minimum recorded differential pressure)

.0.

15. DP Maximum Value

d.P.H.I.

(Resolution is 1 Pa or 1 mmWc)

. . .

(displays maximum recorded differential pressure)

.0.

16. Min Max Reset

H.I. . .

(Pressing <SILENCE> resets the min max values)

L.o. . .

(Press <Menu> to exit menu and retain min/max values)

r.s.t.

Note that only the setpoints that are configured will be shown. For example, if TEMP ALARM OPERATION is set for High Alarm only, then the TEMP Alarm Low Setpoint will not be shown.

Note that the setpoint resolution is limited when setting with the menu, but higher resolution is available via the network.

SPECIFICATIONS

GENERAL

Operating Conditions	0 - 50 °C (32 - 122 °F), 0 - 90 %RH non-condensing
Storage Temperature	-20 - 60 °C (-4 - 140 °F)
Power Supply	24-30 Vdc / 20-26 Vac
Power Consumption	200 mA max
Wiring Connections	Pluggable screw terminal block (14 to 22 AWG)
Pressure Connections	Port for 1/8" ID tubing

Enclosure - Wall Mount:
SS304, suitable for wipe-down.
225mm wide x 182.5mm high x 36mm deep.
(8.86" x 7.19" x 1.46")

Weight	1.3 kg
Certification	CE, RoHS

TEMPERATURE

Sensor Type	10KΩ NTC thermistor sensor
Temperature Range	0-50 °C, 32-122 °F
Accuracy	± 0.2 °C (± 0.4 °F) curve matched

RELATIVE HUMIDITY

Sensor Type	Thermoset polymer based capacitive sensor
RH Range	0-100 %RH
Accuracy	± 2 %RH
Hysteresis	± 1.5%RH
Stability	± 1.2 %RH typical @ 50 %RH in 5 years

DIFFERENTIAL PRESSURE INPUT (CRA, CRB MODELS):

Sensor Type	MEMS piezo resistive differential sensor
Pressure Ranges	01 ± 250 Pa or ± 25 mmWc 02 ± 500 Pa or ± 50 mmWc
Accuracy	± 0.5 %FS
Stability	± 0.5 %FS max (1 year)
Thermal Effect	< ± 1 %FS, 0-70 °C (32-158 °F)
Proof Pressure	24.9 kPa (2490 mmWc)
Burst Pressure	74.7 kPa (7470 mmWc)
Media Compatibility	Dry air or inert gas

INDICATION

Temperature Display	3 digit LED as 0.0-50.0 °C or 32.0-122 °F (°C / °F is indicated by an LED)
Relative Humidity Display	3 digit LED as 0.0-99.9 %RH
Differential Pressure Display	3 1/2 digit LED display as -500-500 Pa or -50.0-50.0 mmWc (Pa / mmWc is indicated by an LED)
Digit Type	7 segment red LED, 0.80" (20.32 mm) high
Alarm Indication	Low/High alarm red LED for each

USER INPUT

Programming	Menu / Up / Down front panel tactile keys
Alarm Silence	Silence front panel tactile key

ANALOG OUTPUTS

Signal Type	4-20 mA (sourcing) and 0-5 Vdc / 0-10 Vdc selectable
Number of Outputs	3 (Temp, RH, DP)
Output Drive	500 Ω max for 4-20 mA, 10 KΩ min for voltage
Output Scales	0-50 °C, 0-100 %RH, ± 500 Pa

ALARM OUTPUTS

Number of Outputs	3 (Temp, RH, DP) can assign condition as low/high/both
Output Type	NO optically isolated solid state FET switch
Contact Rating	100 mA at 28 Vac / 40 Vdc maximum
Trip Point	Upper and Lower alarms adjustable over a range
Alarm Delay	0 to 255 seconds (programmable)
Operation	Self-resetting, non-latching
Alarm Buzzer	Internal, operates on any alarm condition
Buzzer Delay	0-255 seconds (programmable)
Buzzer DB	70db at 30cm
Operation	Self-resetting, can be silenced via key or disabled remotely

COMMUNICATION

Hardware	Isolated 2-wire RS-485 MS/TP
Software	Modbus RTU or BACnet®
Baud Rate	9600, 19200, 38400, 57600, 76800 or 115200
Address Range	1-255 for Modbus, 0-127 for BACnet®

DIMENSIONS

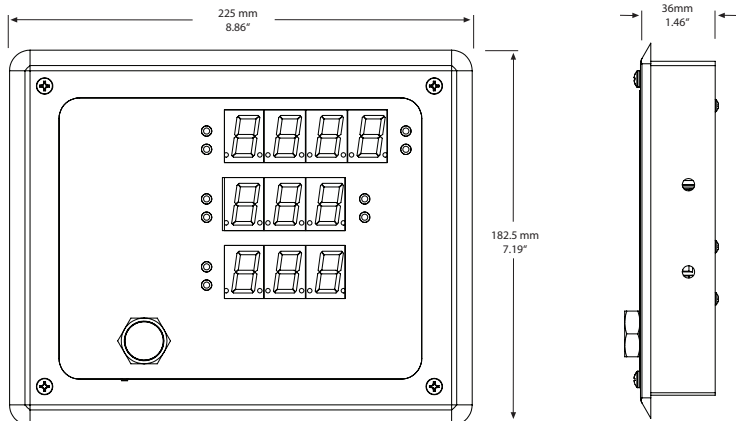

NETWORK SETUP GUIDE

The network set up guide describes the implementation of the BACnet® or Modbus protocol. It is intended to assist control system programmers who may need to add support to their systems to communicate with this device.

BACnet® and Modbus setup guide downloads are available online.



BACNET® PROTOCOL

<http://downloads.greystoneenergy.com/SG/SG-CR3XXXBAC-002.pdf>



MODBUS PROTOCOL

<http://downloads.greystoneenergy.com/SG/SG-CR3XXXMOD-002.pdf>

