

# Modbus Carbon Monoxide Transmitter

Installation Instructions

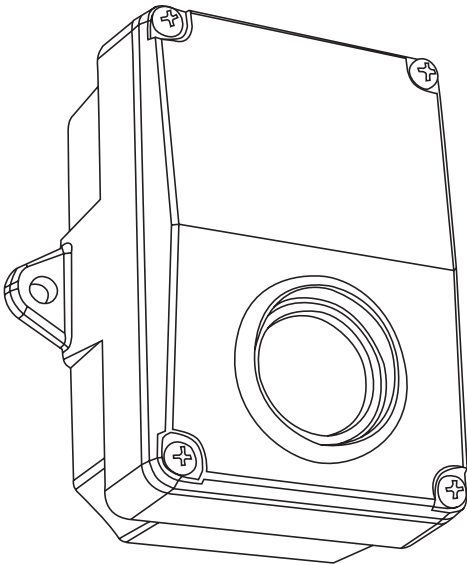

## INTRODUCTION

The Carbon Monoxide Transmitter uses an electrochemical sensor to monitor CO levels in a range of 0 to 500 ppm and communicates via an RS-485 network configured for Modbus protocol.

## BEFORE INSTALLATION

Read these instructions carefully before installing and commissioning the CO transmitter. Failure to follow these instructions may result in product damage. Do not use in an explosive or hazardous environment, with combustible or flammable gases, as a safety or emergency stop device or in any other application where failure of the product could result in personal injury. **Take electrostatic discharge precautions during installation and do not exceed the device ratings.**

## MOUNTING

The transmitter should be mounted on a flat surface three to five feet from the floor of the area to be controlled. Do not mount the sensor near doors, opening windows, supply air diffusers, or other known air disturbances. Avoid areas with vibrations or rapid temperature changes.

The transmitter has two integrated mounting tabs on either side of the enclosure that facilitate a #10 size screw (not supplied). See Figure 1.

Remove the cover from the enclosure by loosening 4 Phillips screws in each corner of the enclosure as seen in Figure 2.

Complete wiring instructions on page 2. Re-install the cover and tighten the screws with a Phillips screwdriver. See Figure 3.

Figure 1

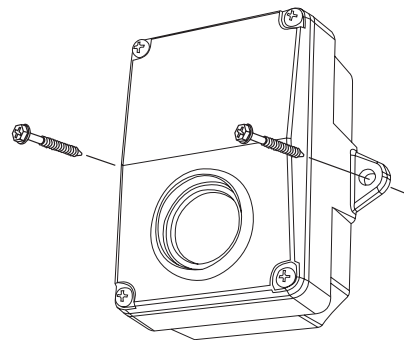

Figure 2

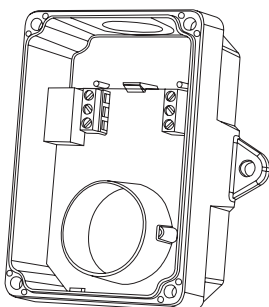
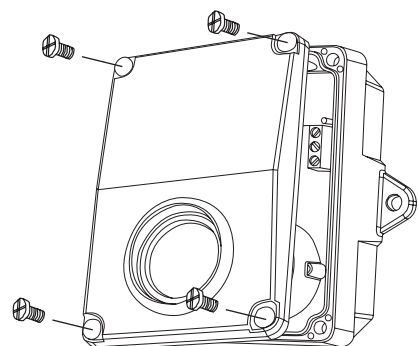

Figure 3



# WIRING

Use 22 AWG shielded wire for all connections and do not locate the device wires in the same conduit with wiring used to supply inductive loads such as motors. Disconnect the power supply before making any connections to prevent electrical shock or equipment damage. Make all connections in accordance with national and local codes.

This device has a half-wave type power supply so use caution when wiring multiple devices so that the circuit ground point is the same on all devices and the controller. This device is reverse voltage protected and will not operate if the power supply is connected backwards.

Connect the RS-485 network with twisted shielded pair to the terminals marked A-, B+ and SHIELD. The

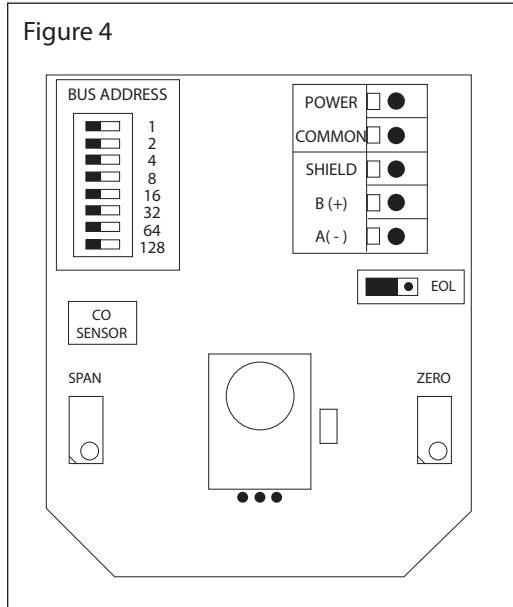

positive wire connects to B(+) and the negative wire connects to A(-) and the cable shield must be connected to the SHIELD terminal on each device. If the device is installed at either end of the network, an end-of-line (EOL) termination resistor (121 Ω) should be installed in parallel to the A(-) and B(+) terminals. This device includes a network termination jumper and will connect the resistor correctly on the PCB. Simply move the PCB jumper to the EOL position and no external resistor is required. The ground wire of the shielded pair should be connected to earth ground at the end of the network and the master is not grounded. Do not run bus wiring in the same conduit as line voltage wiring.

A network segment is a single shielded wire loop run between several devices (nodes) in a daisy chain configuration. The total segment length should be less than 1220 meters (4000 feet) and the maximum number of nodes on one segment is 255 for Modbus. Nodes are any device connected to the loop and include

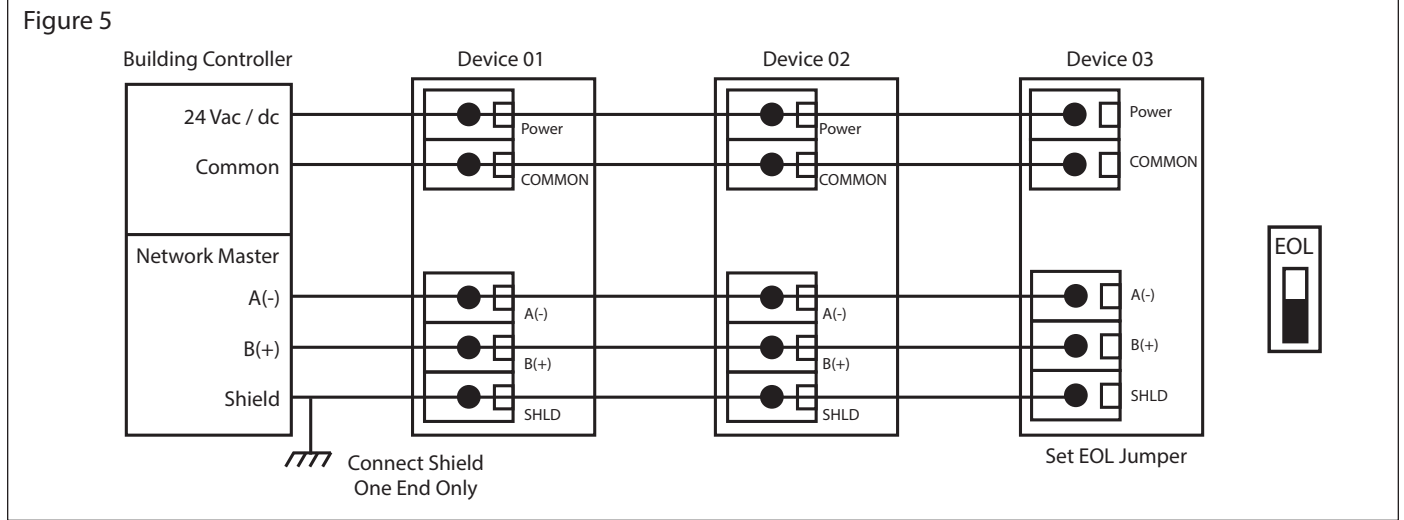

controllers, repeaters and sensors such as the CO Sensor but does not include the EOL terminators. To install more devices, or to increase the network length, repeaters will be required for proper communication. The maximum daisy chain length (segment) depends on transmission speed (baud rate), wire size and number of nodes. If communication is slow or unreliable, it may be necessary to wire two daisy chains to the controller with a repeater for each segment.

## NETWORK COMMUNICATION

Each device must have a unique Modbus address for startup and it must be set before connection to the network. The local DIP switch is used to set the Modbus device address (1-255). The factory default baud rate is 9600. Other Modbus parameter settings can be found in the Specifications section.

The CO Sensor operates as a slave. It will not communicate unless a master is connected to the network and sends a request for information, then the slave will answer. If the device does not communicate properly, first check that the communication wires are not reversed. Then check that the slave address, baud rate, transmission mode, parity bit, stop bit and RTU mode CRC polynomial are correct.

Set the device address as shown below. Each device on the network must have a unique address.

DIP Switch Position								Modbus Address
128	64	32	16	8	4	2	1	
OFF	OFF	OFF	OFF	OFF	OFF	OFF	ON	1
OFF	OFF	OFF	OFF	OFF	OFF	ON	OFF	2
OFF	OFF	OFF	OFF	OFF	OFF	ON	ON	3
OFF	OFF	OFF	OFF	OFF	ON	OFF	OFF	4
↓	↓	↓	↓	↓	↓	↓	↓	↓
ON	ON	ON	ON	ON	ON	ON	OFF	254
ON	ON	ON	ON	ON	ON	ON	ON	255

## CALIBRATION

The CO sensor features a simple snap-mount sensor PCB that is pre-calibrated. This means that the entire sensor PCB can simply be replaced with a new calibrated PCB if desired without having to remove the enclosure. This sensor swap requires no tools and can be completed in seconds. Simply disconnect the device wiring, remove the old sensor PCB, snap in the new PCB and reconnect the device power. There is no need to make any adjustments or apply gas to the device using the sensor swap method.

The device may also be calibrated or verified with CO gas if required. This requires a field calibration kit consisting of a bottle of gas (250 ppm CO in air for example), a tank pressure regulator with flow restrictor and the necessary tubing with a calibration cap to cover to the sensor. Calibration can be done at 20 to 27 °C.

Verification with gas can be done without removing the device cover. Simply apply gas using the calibration cap attached directly to the port on the cover and monitor the output value.

Remove the device cover to perform an actual calibration. In this case, the gas calibration cap attaches to the sensor fixture inside the enclosure. The sensor must be continuously powered for at least 1/2 hour prior to calibration. Calibrate the sensor first in clean air with no CO gas present. Simply adjust the ZERO pot on the sensor board until a 0 ppm output is obtained.

Then attach the gas supply. Turn the regulator on/off knob fully off and attach it to the 250 ppm gas bottle and firmly tighten it by hand. Moisten the sponge and squeeze out any excess water. Place the sponge in the cap so that it will not touch the sensor but does not plug the hole in the side of the cap. Attach the cap to the fixture over the sensor. Slowly turn the valve knob on the regulator to let the gas begin flowing.

The regulator will restrict the flow rate to the specified 200 ml/min and the sponge will ensure the gas is in the right humidity range. Wait for 5 minutes and then adjust the SPAN pot on the sensor board until the output value reads 250 ppm. Close the valve on the tank and take the cap off from the sensor. Calibration is complete.

If the gas cap is too loose on the fixtures, simply place a wrap of electrical tape around the cap to tighten.

Figure 6

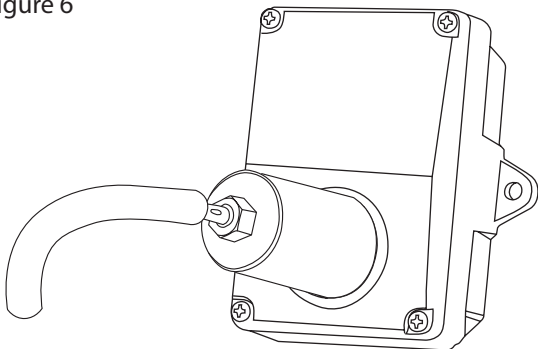
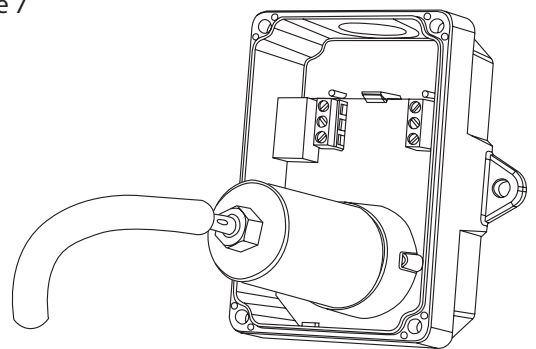

Figure 7



# MODBUS PROTOCOL

This section describes the implementation of the Modbus protocol used in the CO sensor. It is intended to assist control system programmers who may need to add support to their systems to communicate with this device. The CO sensor communicates on a standard Modbus network using RTU mode transmission. It operates as a slave device (address from 01 to 255) and expects a Modbus master device to transmit queries, which it will answer. The network parameters (except for the device address) are fixed at the factory to the most common application. For custom parameters (such as a different baud rate or ASCII transmission mode) contact the factory.

## RTU MESSAGE FORMAT

Modbus Framing	8 bit binary
Data Bits	start bits --- 1 data bits --- 8 parity bits --- none stop bits --- 1
Baud Rate	9600
Duplex	Half duplex
Error Checking	Cyclical Redundancy Check (CRC) CRC-16 reverse 0xA001
Latency	More than 3.5 characters --- minimum

## FRAMING SUPPORT AND BIT SEQUENCES

RTU Mode	Start	1	2	3	4	5	6	7	8	Stop
----------	-------	---	---	---	---	---	---	---	---	------

## MODBUS REGISTER ADDRESSING

Modbus Address	Typical Offset	Units	Data Type	Access	Notes
40001	+0		Word	Read	Unsigned 16-bit integer 0x0000 = CO in normal status, 0x0001 = in abnormal status
40002	+1	PPM	Word	Read	Unsigned 16-bit integer, CO value

## FUNCTION CODES (RTU MODE)

0x03 --- Read holding registers

Query

Slave address (0x01 to 0xFF)	Function code (0x03)	Starting address MSB	Starting address LSB	Quantity of registers MSB	Quantity of registers LSB	CRC LSB	CRC MSB
---------------------------------	----------------------	----------------------	----------------------	---------------------------	---------------------------	---------	---------

\* Starting address = 0x0000 to 0xFFFF, Quantity of registers = 0x0000 to 0x007D

Response

Slave address (0x01 to 0xFF)	Function code (0x03)	Byte count 2N	Register value MSB	Register value LSB	...	CRC LSB	CRC MSB
---------------------------------	----------------------	------------------	--------------------	--------------------	-----	---------	---------

\* N=Quantity of registers

Exception response

Slave address (0x01 to 0xFF)	Function code + 0x80	Exception code 0x01, 0x02 or 0x03	CRC LSB	CRC MSB
---------------------------------	----------------------	--------------------------------------	---------	---------

\* An exception response is only returned if the CRC is correct  
Exception code 01 --- illegal function, 02 --- illegal address, 03 --- illegal data value

# The RTU function codes supported by the co sensor are shown below.

## 0x03 --- Read CO Status

### Query

Slave address (0x01 to 0xFF)	0x03	0x00	0x00	0x00	0x01	CRC LSB	CRC MSB
---------------------------------	------	------	------	------	------	------------	------------

### Response

Slave address (0x01 to 0xFF)	0x03	0x02	Register value 0x00	Register value LSB	CRC LSB	CRC MSB
---------------------------------	------	------	------------------------	-----------------------	------------	------------

\* Register value = 0x0000 in normal status, 0x0001 in abnormal status

## 0x03 --- Read CO PPM

### Query

Slave address (0x01 to 0xFF)	0x03	0x00	0x01	0x00	0x01	CRC LSB	CRC MSB
---------------------------------	------	------	------	------	------	------------	------------

### Response

Slave address (0x01 to 0xFF)	0x03	0x02	Register value MSB (PPM)	Register value LSB (PPM)	CRC LSB	CRC MSB
---------------------------------	------	------	-----------------------------	-----------------------------	------------	------------

\* Register value = 0x0000 to 0x01F4, corresponding to 0 to 500 ppm

### Exception response

Slave address (0x01 to 0xFF)	Function code + 0x80	Exception code * 0x01, 0x02 or 0x03	CRC LSB	CRC MSB
---------------------------------	-------------------------	--	------------	------------

\* An exception response is only returned if the CRC is correct

Exception code 01 --- illegal function, 02 --- illegal address, 03 --- illegal data value

## SPECIFICATIONS

### GENERAL

Measurement.....	Electrochemical
Sample Method .....	Diffusion
Measurement Range.....	0 to 500 ppm
Accuracy .....	±5 ppm or ±5% of reading (whichever is greater) 0 to 50°C (32 to 122°F), 15 to 90 %RH
Agency Approvals .....	Sensor is UL recognized for ANSI/UL-2034 and UL-2075, E240671
Operating Conditions .....	-20 to 50°C (-4 to 122°F), 15 to 90 %RH, 0.9 - 1.1 atm
Stability .....	<5% signal loss/year
Response Time .....	<35 seconds for 90% step change
Typical Area Coverage .....	700 m <sup>2</sup> (7500 ft <sup>2</sup> ) or 15m (50ft) radius
Power Supply .....	24 Vdc ±20%
Consumption .....	35 mA max
Wiring Connections.....	Screw terminal block (14 to 22 AWG)
Enclosure .....	71mm W x 104mm H x 48mm D (2.8" x 4.1" x 1.9")
Country of Origin.....	Canada

### MODBUS

Hardware .....	2 wire RS-485
Software.....	Native Modbus MS/TP protocol (RTU)
Baud Rate .....	9600
Slave Address Range .....	Locally set to 1-255
Parity .....	None
Stop Bits.....	1
CRC .....	A001 (CRC-16 reverse)

\*NOTE: Modbus parameters may be factory customized.

# DIMENSIONS

