

Duct Carbon Dioxide Detector

Installation Instructions

INTRODUCTION

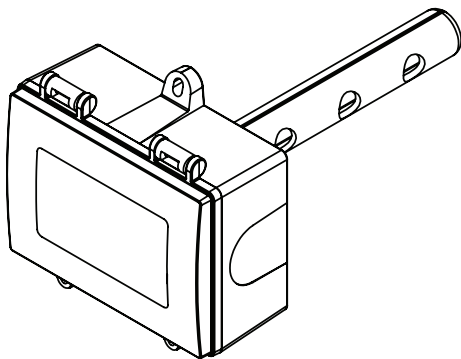

The CO₂/RH/T transmitter incorporates three sensors in one duct mount enclosure for the most efficient environmental monitoring and control system. It uses Infrared Technology to monitor CO₂ levels within a range of 0 – 10000 ppm, a field-proven RH sensor to monitor relative humidity from 0-100 %RH and a curve-matched thermistor to measure temperature over common field-selectable ranges. The device includes an LCD for configuration and operating parameters are programmed using a keypad for specific applications. Options include a control relay.

The device includes native BACnet® protocol and an RS-485 MS/TP network connection to offer a single-point solution for control of indoor air quality and comfort. Features include a back-lit LCD and user menu for easy installation.

BEFORE INSTALLATION

Read these instructions carefully before installing and commissioning the transmitter. Failure to follow these instructions may result in product damage. Do not use in an explosive or hazardous environment, with combustible or flammable gases, as a safety or emergency stop device or in any other application where failure of the product could result in personal injury. **Take electrostatic discharge precautions during installation and do not exceed the device ratings.**

NOTE: This CO₂ sensor incorporates a Self Calibration feature to correct CO₂ sensor drift. This feature is recommended for applications where the CO₂ will be exposed to fresh air (400 ppm) at least one hour per day. If the monitored space is occupied 24 hours or consistently maintains higher or lower levels of CO₂, it is recommended that this feature be turned off, but yearly calibration will be required. If the self calibration is disabled at installation time without allowing for 7 day auto calibration cycle, then a manual calibration should be performed to ensure accuracy of the device.

MOUNTING

The duct type sensor installs on the outside of a return air duct with the sampling tube inserted into the duct.

Mount the sensor in an easily accessible location in a straight section of duct at least five feet from corners and other items that may cause disturbances in the air flow. Avoid areas where the detector is exposed to vibrations or rapid temperature changes.

The duct CO₂ detector principal of operation is based on the Venturi effect of the probe that extends into the HVAC duct. Air flowing through the duct is forced into the vent holes on one side of the probe, into the enclosure, over the CO₂ sensor and then is drawn back out of the enclosure via the probe vent holes on the opposite side.

NOTE to ensure proper humidity and temperature readings, the RH/T inlet on the probe must be installed directly into the airflow. See Figure 1.

Drill or punch a 7/8" or 1" hole in the duct at the preferred location and insert the probe into the hole to mark the enclosure mounting holes. Remove the unit and drill the two mounting holes. Clean all drilled holes of debris before mounting the device.

Figure 1

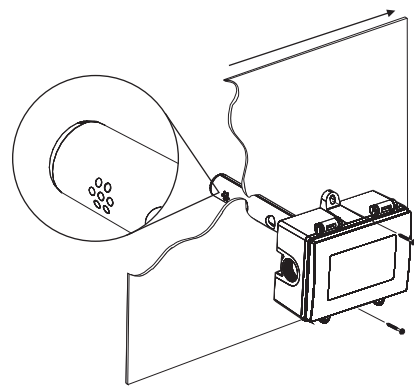
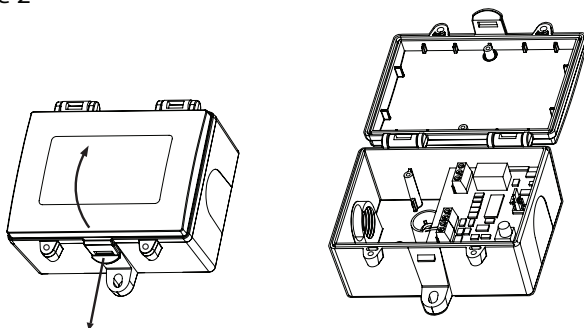

Figure 2



Mount the enclosure to the duct with two sheet metal screws such that the duct air flow is parallel with the vent holes in the probe (i.e.: air flows directly into the probe holes). To prevent air leaks, ensure the gasket is compressed around the probe between the device enclosure and the air duct. See Figure 1.

The enclosure has a hinged cover with a latch. Open the cover by pulling slightly on the latch on the right side of the enclosure, at the same time pulling on the cover, as illustrated in Figure 2.

A 1/2" NPT threaded connection hole is provided in the left side of the enclosure. Screw the EMT connector or cable gland connector in until tight. See Figure 3. It is recommended that weatherproof conduit or cable gland fittings be used. The F style enclosure includes a 1/2" NPT to M16 thread adapter and cable gland fitting. Insert the provided foam plug in the EMT opening to prevent air from entering the enclosure through the EMT.

Make wiring connections as per the "Wiring" illustrations in Figure 6.

Swing door closed until securely latched. For added security, 2 screws are provided that may be installed in the integrated screw tabs. See Figure 4.

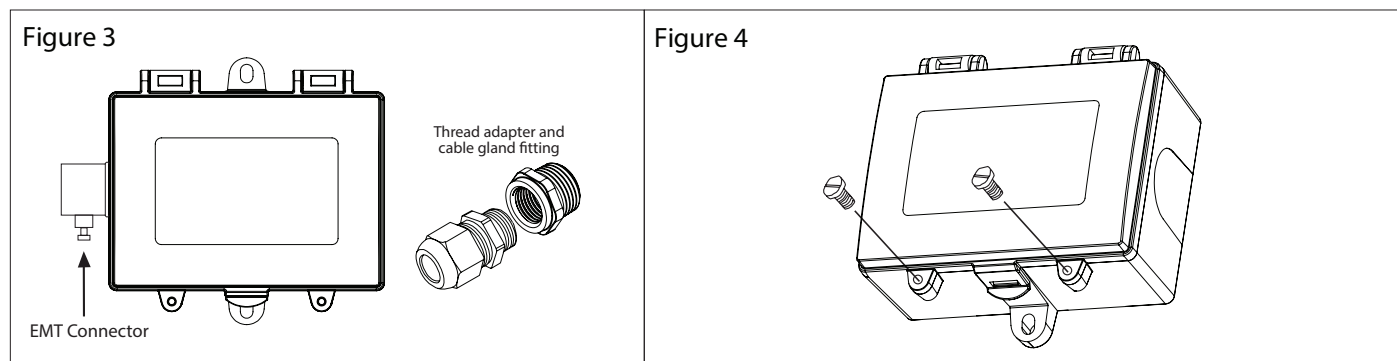

WIRING

Deactivate the 24 Vac/dc power supply until all connections are made to the device to prevent electrical shock or equipment damage. Follow proper electrostatic discharge (ESD) handling procedures when installing the device or equipment damage may occur.

Use 22 AWG shielded wiring for all connections and do not locate the device wires in the same conduit with wiring used to supply inductive loads such as motors. Make all connections in accordance with national and local codes.

Connect the 24 Vac/dc power supply to the terminals labeled POWER and COMMON. Use caution if 24 Vac power is used and one side of the transformer is earth-grounded. In general, the transformer should NOT be connected to earth ground when using devices with RS-485 network connections. The device is reverse voltage protected and will not operate if connected backwards.

Connect the RS-485 network with twisted shielded pair to the terminals marked A(-), B(+) and SHIELD. The positive wire connects to B(+) and the negative wire connects to A(-) and the cable shield must be connected to the SHIELD terminal on each device.

If the device is installed at either end of an RS-485 network, an end-of-line (EOL) termination resistor (121 ohm) should be installed in parallel to the A(-) and B(+) terminals. This device includes a network termination jumper and will connect the 121 ohm resistor correctly on the PCB.

Simply move the jumper to the EOL position and no external resistor is required. The ground wire of the shielded pair should be connected to earth ground at the end of the network and the master is not grounded.

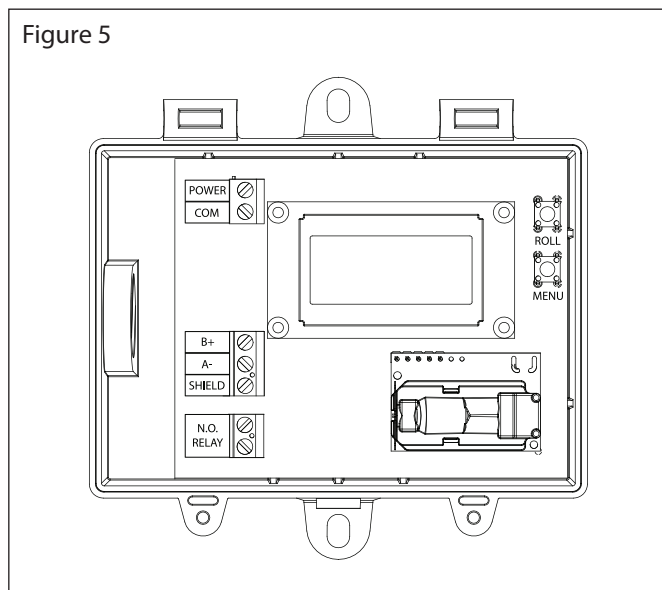

Do not run bus wiring in the same conduit as line voltage wiring or other wiring that switches power to highly inductive loads such as contactors, coils or motors.

A network segment is a single shielded wire loop run between several devices (nodes) in a daisy chain configuration. The total segment length should be less than 4000 feet (1220 meters) and the maximum number of nodes on one segment is 127. Nodes are any device connected to the loop and include controllers, repeaters and sensors such as the CHT but do not include the EOL terminators.

To install more than 127 devices, or to increase the network length, repeaters will be required for proper communication. The maximum daisy chain length (segment) depends on transmission speed (baud rate), wire size and number of nodes. If communication is slow or unreliable, it may be necessary to wire two daisy chains to the controller with a repeater for each segment.

An optional signal is the relay output available on the N.O. RELAY terminals. The relay output is completely isolated and has a Normally Open (NO) signal. This signal can be used to directly control an alarm or ventilation fan.

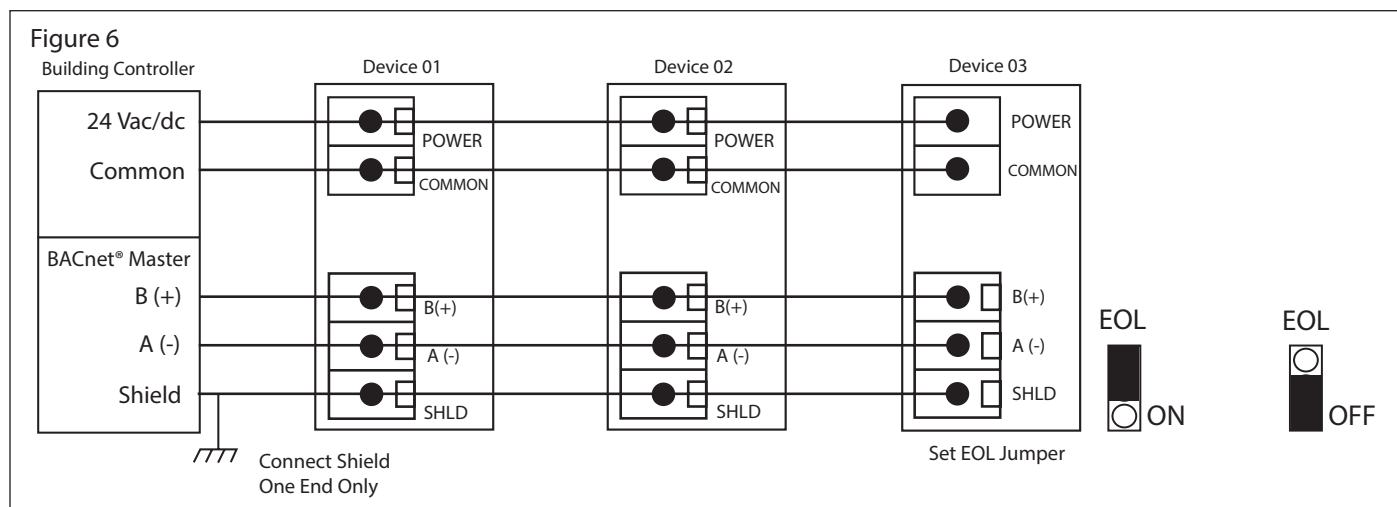

SET-UP

The device parameters must be set before connection to the network and will ensure each device will have a unique MAC address and Device Instance for startup. On startup, the MAC address is appended to the Device Object : Vendor Identifier to create the unique Device Instance (Device Object : Object Identifier). Once connected to a network, the Device Object : Object Identifier can be written to any unique value via BACnet and then the MAC address will no longer be appended to the value. Once set, all parameters are saved in non-volatile memory. The local menu and LCD are used to set the BACnet MAC device address (0-127) and the baud rate. The factory defaults are address 3 and 9600 baud. The menu and setup procedure is described in the Start-up section.

START-UP

On start-up, the LCD will indicate the software version number, the baud rate and the MAC address.

OPERATION

In normal operation the device reads the CO₂, RH and temperature sensors and updates the object values accordingly. The LCD displays the sensor values as determined by the display mode object.

USER MENU

The User Menu has several items as shown below. To enter the menu, press and release the <MENU> key while in normal operation. This will enter the User Menu step 1, pressing the <MENU> key a second time advances to step 2 The <ROLL> key is used to make changes to program variables by scrolling through the available options.

NOTE: If no keys are pressed for 5 minutes, the menu will automatically exit.

<MENU> Press and release to enter the SETUP menu

1. BAUD RATE

BaudRate
9600

Use <ROLL> to select a baud rate of 9600, 19200, 38400, 57600, 76800 or 115200. The default BACnet® baud rate is 9600.

<MENU> Press to advance to next menu item

2. ADDRESS

BACnet
MAC 3

Use <ROLL> to select a unique MAC address from 0-127. The default BACnet® MAC address is 3. Hold <ROLL> for 1 second to increment quickly.

<MENU> Press to advance to next menu item

3. RELAY TEST

RELAY
Test Off

Use <ROLL> to activate relay for testing, LCD will show Test On. Press <ROLL> again to set Relay to Off.

<MENU> Press to advance to next menu item

4. BACKLIGHT

Backlite
Auto

Use <ROLL> to enable, disable or set to auto the LCD backlight. When enabled the LCD backlight is always on, when disabled it never lights and if it is set to Auto it lights for a time period (30 seconds) whenever a key is pressed. Press <MENU> to save and advance. The factory default is Auto.

Menu
Exit

Press <MENU> or <ROLL> to exit the menu and return to normal operation.

5. CALIBRATION

Calibrat
1000 ppm

This item is used for 1000 ppm gas calibration and is explained in the *Calibration* section.

<MENU> Press to advance to next menu item

CALIBRATION

The RH and temperature measurements typically do not need any calibration for the life of the product. Both values have Analog Value Objects and may have user offsets assigned via the network. Please refer to BACnet® Network Setup Guide.

CO₂ calibration with gas requires a field calibration kit with pressure regulator, sensor hood, necessary tubing and appropriate bottles of CO₂ gas. The unit requires only a single point 1000 ppm calibration to meet specified accuracy due to the Automatic Calibration mode and other technology incorporated into the model.

1000 PPM CALIBRATION

Turn the regulator knob off and connect the 1000 ppm CO₂ gas bottle and hand tighten. Remove the cover of the unit to be calibrated to expose the gas sensor. The tubing from the gas bottle can be connected to the calibration hood. The hood should be placed over the CO₂ sensor and pressed down flush with the PCB. Turn on the 1000PPM gas. The CO₂ reading on the LCD will begin to approach 1000 ppm. Wait 1 to 2 minutes until the CO₂ reading stabilizes.

Enter the Setup menu and use the <MENU> key to advance to Calibrat 1000 PPM. Press and hold the <UP> key for 2 seconds and the display will change. When calibration is complete the unit will display the ppm value and Cal Done. Press the <SAVE> key to return to normal operation and shut the gas off

SPECIFICATIONS

CO₂

Sensor Type: Dual channel non-dispersive infrared (NDIR)
Measurement Range: 0-10,000ppm
Accuracy: ± (30ppm + 3% of measured value)
Temperature Dependency:..... ±2.5ppm/ °C
Sensor Life Span: >15 years
Response Time: 20 seconds (T63)
Warm-up Time: 1 minute

RELATIVE HUMIDITY

Measurement Range: 0-100 %RH, non-condensing
Accuracy: ±2 %RH (5 to 95 %RH)
Resolution: ±0.01 %RH
Hysteresis: ±0.8 %RH @ 25°C (77°F)
Response Time: 8 seconds typical
Stability: <0.25 %RH/year

TEMPERATURE

Range: 0 to 50°C (32 to 122°F)
Accuracy: ±0.2°C
Resolution: 0.1°C

NETWORK INTERFACE

Hardware: 2-wire RS-485
Software: Native BACnet MS/TP protocol
Baud Rate: 9600, 19200, 38400, 57600, 76800 or 115200
MAC Address Range: 0-127 (Default is 3)

OPTIONAL RELAY

Contact Ratings:..... Form A contact (N.O.), 2 Amps @ 140 Vac, 2 Amps @ 30 Vdc
Relay Trip Point:..... Programmable via BACnet® object
Relay Hysteresis:..... Programmable via BACnet® object

GENERAL SPECIFICATIONS

Power Supply:..... 20 - 28 Vac/dc (non-isolated half-wave rectified)
Consumption:..... 120 mA max @ 24 Vdc, 212 mA max @ 24 Vac
Storage Temperature: -20 to 60°C (-4 to 140°F)
Operating Conditions: 0 to 50°C (32 to 122°F), 0-95 %RH non-condensing
Enclosure:..... Polycarbonate, UL94-V0, IP65 (NEMA 4X)
Dimensions: 116.5mm x 99.7mm x 53.7mm (4.6" x 3.9" x 2.1")
Probe Dimensions: 152mm L x 22.5mm D (6" x 0.85")
Wiring Connections: Screw terminal block (14 to 22 AWG)
Approvals: CE
Country of Origin:..... Canada

DIMENSIONS

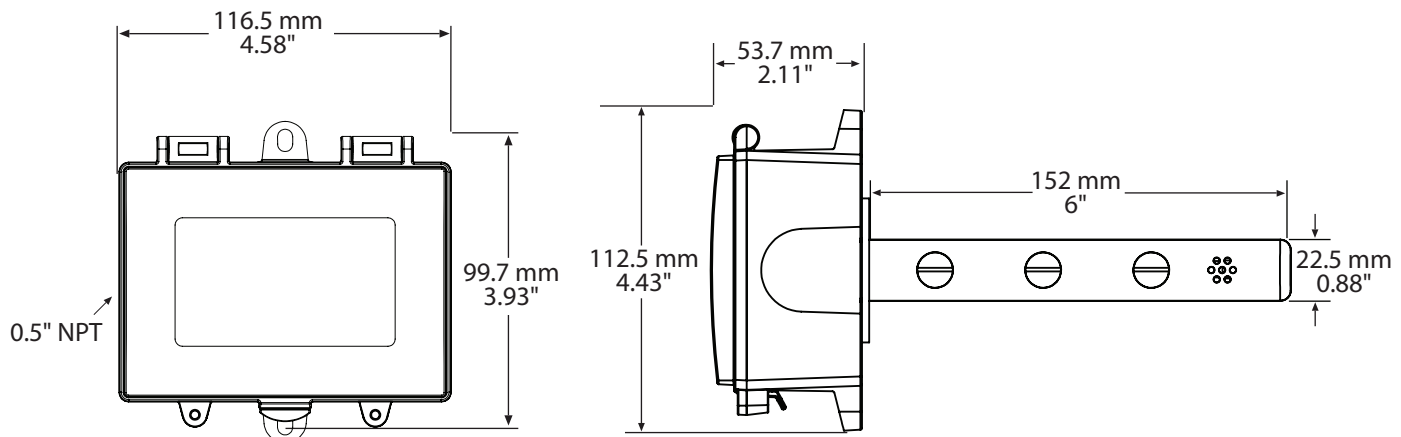

NETWORK SETUP GUIDE

The network setup guide describes the implementation of the BACnet® protocol. It is intended to assist control system programmers who may need to add support to their systems to communicate with this device.

BACnet® setup guide download is available online.



BACnet® PROTOCOL

<https://downloads.greystoneenergy.com/SG/SG-CHTXXXBAC-002.pdf>