

Duct Carbon Dioxide Detector

Installation Instructions

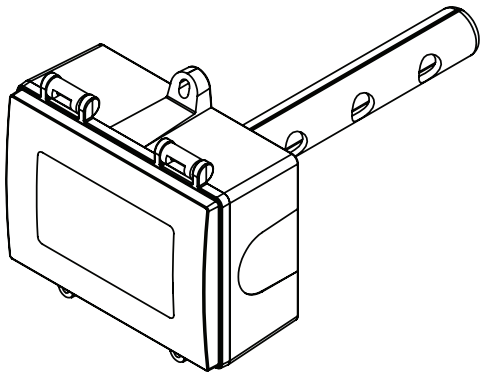

INTRODUCTION

The CO₂/RH/T transmitter incorporates three sensors in one duct mount enclosure for the most efficient environmental monitoring and control system. It uses Infrared Technology to monitor CO₂ levels within a range of 0 – 2000 ppm, a field-proven RH sensor to monitor relative humidity from 0-100 %RH and a curve-matched thermistor to measure temperature over common field-selectable ranges. All three measurements are continuously available on separate outputs as linear analog signals. The device includes an LCD for configuration and operating parameters are programmed using a keypad for specific applications. Options include a control relay. This product is also available with voltage output signals instead of 4-20 mA.

BEFORE INSTALLATION

Read these instructions carefully before installing and commissioning the transmitter. Failure to follow these instructions may result in product damage. Do not use in an explosive or hazardous environment, with combustible or flammable gases, as a safety or emergency stop device or in any other application where failure of the product could result in personal injury. **Take electrostatic discharge precautions during installation and do not exceed the device ratings.**

MOUNTING

The duct type sensor installs on the outside of a return air duct with the sampling tube inserted into the duct.

Mount the sensor in an easily accessible location in a straight section of duct at least five feet from corners and other items that may cause disturbances in the air flow. Avoid areas where the detector is exposed to vibrations or rapid temperature changes.

The duct CO₂ detector principal of operation is based on the Venturi effect of the probe that extends into the HVAC duct. Air flowing through the duct is forced into the vent holes on one side of the probe, into the enclosure, over the CO₂ sensor and then is drawn back out of the enclosure via the probe vent holes on the opposite side.

NOTE: to ensure proper humidity and temperature readings, the RH/T inlet on the probe must be installed directly toward the airflow See Figure 1.

Drill or punch a 7/8" or 1" hole in the duct at the preferred location and insert the probe into the hole to mark the enclosure mounting holes. Remove the unit and drill the two mounting holes. Clean all drilled holes of debris before mounting the device.

Mount the enclosure to the duct with two sheet metal screws such that the duct air flow is parallel with the vent holes in the probe (i.e.: air flows directly into the probe holes). To prevent air leaks, ensure the gasket is compressed around the probe between the device enclosure and the air duct.

The enclosure has a hinged cover with a latch. Open the cover by pulling slightly on the latch on the bottom of the enclosure, at the same time pulling on the cover, as illustrated in Figure 2.

A 1/2" NPT threaded connection hole is provided in the left side of the enclosure. Screw the EMT connector or cable gland connector in until tight. See Figure 3. It is recommended that weatherproof conduit or cable gland fittings be used. The F style enclosure includes a 1/2" NPT to M16 thread adapter and cable gland fitting.

Make wiring connections as per the "Wiring" illustrations on Page 2.

Swing door closed until securely latched. For added security, 2 screws are provided that may be installed in the integrated screw tabs. See Figure 4.

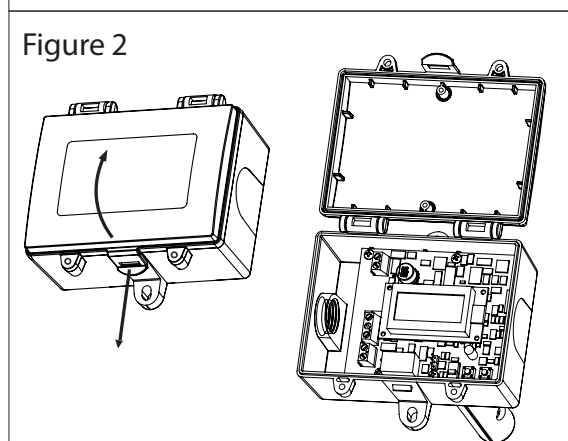
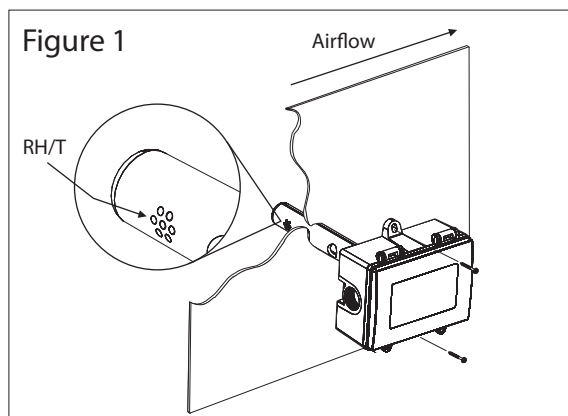

Figure 3

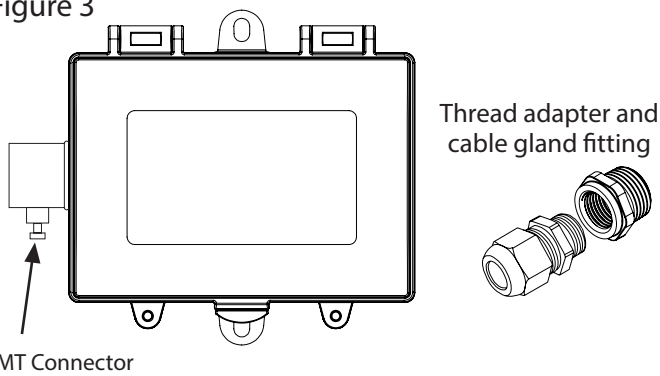
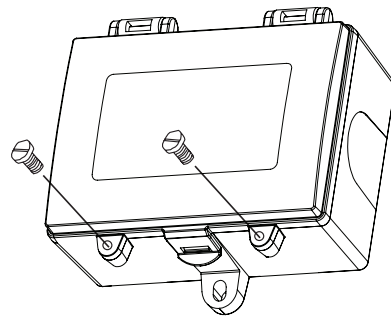

Figure 4



WIRING

- Deactivate the 24 Vac/dc power supply until all connections are made to the device to prevent electrical shock or equipment damage.
- Use 14-22 AWG shielded wiring for all connections and do not locate the device wires in the same conduit with wiring used to supply inductive loads such as motors. Make all connections in accordance with national and local codes.
- Pull at least six inches of wire into the enclosure, then complete the wiring connection according to the wiring diagram for the applicable power supply and output signal type.
- Connect the plus DC or the AC voltage hot side to the Power terminal. For voltage output or AC power, the supply Common is connected to the Common terminal. The device is reverse voltage protected and will not operate if connected backwards. It has a half-wave power supply so the supply Common is the same as the signal Common. See Figure 5.
- The signal type can be ordered as either voltage or 4-20 mA active outputs. The voltage model is selectable for either 0-5 or 0-10 Vdc via the menu (the factory default is 0-5 Vdc). See Figure 5.
- An optional signal is the relay output available on the N.O. RELAY terminals. The relay output is completely isolated and has a Normally Open (NO) signal. This signal can be used to directly control an alarm or ventilation fan.

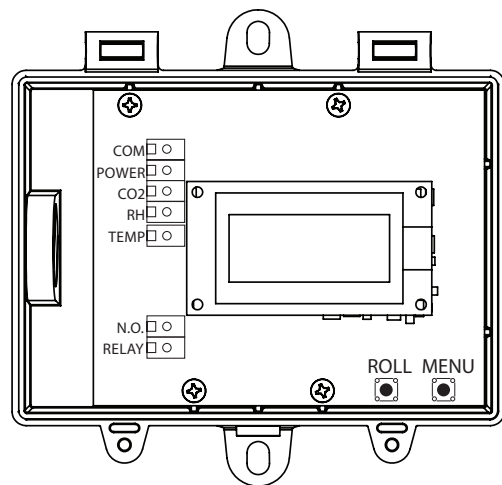
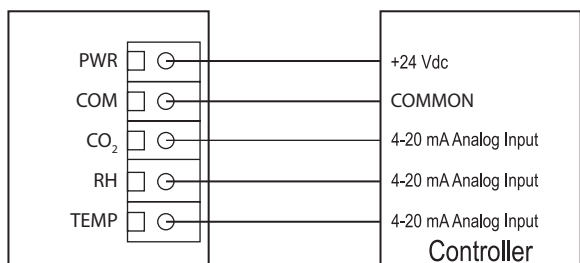
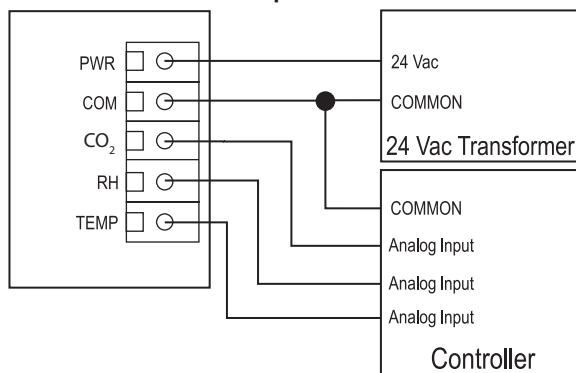

Figure 5

Wiring for 4-20 mA output signal and 24 Vdc external power supply



Wiring for all output signals and external 24 Vac power transformer



Wiring for voltage output signal and 24 Vdc power from controller

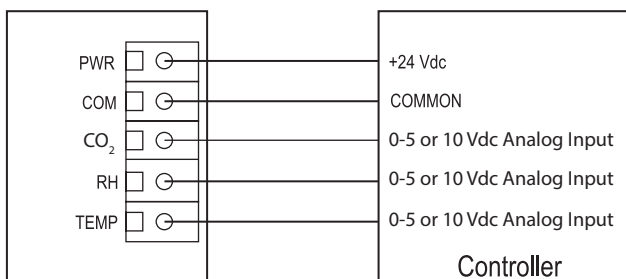

Wiring for 4-20 mA output signal and 24 Vdc external power supply

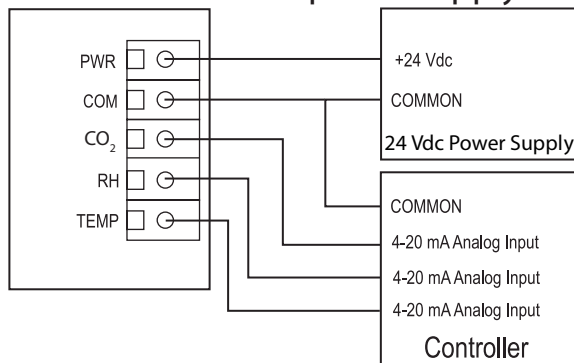

OUTPUTS

The CO₂ output is scaled so that 4-20 mA (or 0-5/0-10Vdc) equals 0 to Out_High as set in the Setup menu. Depending on the model ordered, the factory default is either 0-2000 ppm or 0-20,000 ppm. The Out_High can be changed in the Setup menu and the output signal is scaled accordingly. The RH and temperature outputs operate similar to the CO₂ output. RH is scaled 0-100 %RH and temperature defaults to 0 to 50°C but can be changed to 0 to 35°C, 32 to 95°F or 32 to 122 °F using the Setup Menu. For voltage output models, the factory default is 0-5 Vdc and can be changed to 0-10 Vdc in the Setup Menu.

OPERATION

The CO₂, RH and Temperature signals are connected to the BAS analog inputs. The BAS reads the voltage or current signals and calculates actual values using correct scaling for the ranges and signal type. These values can be used to control ventilation devices or initiate alarms. All values are displayed locally on the LCD. The Setup Menu can be used to modify the displayed information. The display is factory set to display all three measurement values. The CO₂ level will be displayed as 0-2000 ppm or 0-20,000 ppm depending on the model, the %RH will be displayed as 0-99H and the temperature will be displayed as 0 to 50°C. The Setup menu can be used to modify the displayed information. The installer can select to only display CO₂, or to display CO₂ and RH, or alternately CO₂ and temperature. The device supports four temperature ranges that may also be selected in the menu.

The default is 0 to 50°C but this may be changed to 0-35°C and the the output scaling will change. Also, the temperature range may be changed to 32 to 122°F or 32 to 95°F and output signal will stay the same to match the display.

If the optional relay is installed it can directly control a small fan or alarm by setting the trip value and hysteresis to appropriate values. The relay status is not indicated on the device LCD.

USER MENU

The User Menu has several items as shown below. To enter the menu, press and release the <MENU> key while in normal operation. This will enter the User Menu step 1, pressing the <MENU> key a second time advances to step 2. Each press of the <MENU> key saves the selection and advances the menu item. The <ROLL> key is used to make changes to program variables by scrolling through the available options.

NOTE: If no keys are pressed for 5 minutes, the menu will automatically exit.

<MENU> Press and release to enter the setup menu.

Out High
2000 ppm

For single channel NDIR CO₂ model only. The default CO₂ range is 0-2000 ppm. The output span can be changed from 1000 to 7500 ppm in increments of 500. Use <ROLL> to change the value.

Out High
20000 ppm

For dual channel NDIR CO₂ model only. Default CO₂ range is 0-20,000 ppm. The output span can be changed from 2000 to 20,000 ppm in increments of 500. Use <ROLL> to change the value.

<MENU> Press to advance to next menu item

Altitude
0 ft

The default is 0 feet. Change by using <ROLL> from 0 to 5000 feet in 500 foot increments for CO₂ local altitude correction.

<MENU> Press to advance to next menu item

Auto Cal
ON

For single channel NDIR CO₂ model only. Automatic Cal Mode default is ON to correct CO₂ sensor drift to better than ±10 ppm per year. ON is recommended for applications where the CO₂ level will be close to normal (400 ppm) at least once per day. If a building is occupied 24 hours and the CO₂ level is fairly constant then the dual beam sensor should be used.

<MENU> Press to advance to next menu item

Temp C/F
°C

The temperature scale defaults to Celsius (°C). Use <ROLL> to change to Fahrenheit (°F).

<MENU> Press to advance to next menu item

T Range
0-50 °C

Two temperature ranges are available for output scaling, 0-35°C (32-95°F) or 0-50°C (32-122°F). Change using <ROLL>. The available range will depend on the °C or °F menu selection.

<MENU>

Press to advance to next menu item

T Offset

This item allows calibration of the temperature sensor. Use <ROLL> to add an offset to 0°C the temperature signal and display. -1 subtracts 1 degree from the temperature and +1 adds 1 degree to the temperature. The range is -5 to +5°C or -10 to +10°F. Resolution is 0.5°C or 1°F. Units depend on the previous C/F setting and resets to 0° if C/F is changed.

<MENU>

Press to advance to next menu item

H Offset

This item allows calibration of the RH sensor. Use <ROLL> to add an offset to the RH 0 %RH signal and display. -1 subtracts 1 %RH and +1 adds 1 %RH. The range is -10 to +10 %RH.

<MENU>

Press to advance to next menu item

For models with the relay option installed

Relay SP
1000 ppm

The relay trip setpoint default is 1000 ppm. Use <ROLL> to change from 500 to 5000 for the single channel NDIR CO₂ model, in 100 ppm increments, or from 500 to 15,000 for the dual channel NDIR CO₂ model, in 100 ppm increments.

<MENU>

Press to advance to next menu item

Relay Hy
50 ppm

The relay hysteresis default is 50 ppm. Use <ROLL> to change from 25 to 200 for the single channel NDIR CO₂ model, or from 25 to 500 for the dual channel NDIR CO₂ model in 25 ppm increments.

<MENU>

Press to advance to next menu item

Relay
On Delay

The relay on delay time default is 15 seconds. Use <ROLL> to change from 0 to 255 seconds in 1 second increments.

<MENU>

Press to advance to next menu item

For models with the relay option installed continued

Relay
Test OFF

Use <ROLL> to toggle the relay ON or OFF for testing purposes.

<MENU>

Press to advance to next menu item

For models with the voltage output only

Out Type
0-5 Vdc

The default output type is 0-5 Vdc. Use <ROLL> to change to 0-10 Vdc if necessary.

<MENU>

Press to advance to next menu item

Calibrat
0 ppm

For the dual channel NDIR CO₂ model only. This item is used for 0 ppm gas calibration and is explained in the *Calibration* section.

<MENU>

Press to advance to next menu item

Calibrat
1000 ppm

This item is used for 1000 ppm gas calibration and is explained in the *Calibration* section.

<MENU>

Press to advance to next menu item

Calibrat
20000 ppm

For dual channel NDIR CO₂ model only. This item is used for 20,000 ppm gas calibration and is explained in the *Calibration* section.

<MENU> Press to advance to next menu item

BackLite
Auto

Use <ROLL> to enable, disable, or set to auto the LCD backlight. When enabled the LCD backlight is always on, when disabled it never lights, and if set to auto it lights for a time period of 30 seconds whenever a key is pressed. The factory default is Auto.

<MENU> Press to exit the menu and return to normal operation.

CALIBRATION

The RH and temperature measurements typically do not need any calibration for the life of the product. Both values may have user offsets assigned in the Setup Menu.

CO₂ calibration with gas requires a field calibration kit with pressure regulator, necessary tubing and appropriate bottles of CO₂ gas. Note that the procedure depends on the device model.

SINGLE CHANNEL CALIBRATION

Calibration with gas requires a field calibration kit with pressure regulator, necessary tubing and appropriate bottles of CO₂ gas. Note that the procedure depends on the device model. The single channel model requires only a single point 1000 ppm calibration to meet specified accuracy due to the Automatic Calibration mode and other technology incorporated into the model.

1000 PPM CALIBRATION

Turn the regulator knob off and connect the 1000 ppm CO₂ gas bottle and hand tighten. Remove the cover of the unit to be calibrated to expose the gas sensor chamber. The tubing from the gas bottle can be connected to either port on the chamber after the plastic cap is removed. Gently remove one cap and connect the tubing, note that strong shock or vibration can affect calibration. The CO₂ reading on the LCD will begin to approach 1000 ppm. Wait 1 to 2 minutes until the CO₂ reading stabilizes.

Enter the Setup menu and use the <MENU> key to advance to Calibrat 1000 PPM. Press and hold the <SAVE> key for 2 seconds and the display will change to Waiting Calibrat then to Waiting 5 minute to indicate that the device is calibrating. Again, this process takes about 5 minutes. When calibration is complete the unit will display the ppm value and Cal Done. Press the <SAVE> key to return to normal operation and shut the gas off.

Disconnect the tubing and replace the cap on the sensor chamber as calibration is complete.

DUAL CHANNEL CALIBRATION

Calibration with gas requires a field calibration kit with pressure regulator, necessary tubing and appropriate bottles of CO₂ gas.

The dual-channel sensor with extended range requires a 3-point calibration with 0, 1000 and 20,000 ppm gas (in order).

0 PPM CALIBRATION

Turn the regulator knob off and attach it to the Nitrogen gas bottle and hand tighten. Remove the cover of the unit to be calibrated to expose the gas sensor chamber. The tubing from the gas bottle can be connected to either port on the chamber after the plastic cap is removed. Gently remove one cap and connect the tubing, note that strong shock or vibration can affect calibration.

Ensure the device has been operating normally for at least five minutes before applying gas. Turn the valve knob on the regulator to start the gas flow. The regulator will restrict the flow rate to the specified 100 ml/min. After a brief period the gas will flow into the chamber. Wait 1 to 2 minutes until the CO₂ stabilizes.

Enter the Setup menu and use the <MENU> key to advance to Calibrat 0 PPM. Press and hold the <SAVE> key for 2 seconds and the display will change to Waiting Calibrat then to Waiting 5 minute to indicate that the process of setting the internal calibration is taking place.

This takes about 5 minutes while the LCD counts down. Do not disturb the unit or the gas flow. When complete the unit will display the ppm value and Cal Done. Press <SAVE> to resume normal operation and shut the gas off.

1000 PPM CALIBRATION

Connect the 1000 ppm CO₂ gas bottle and apply the gas as before. The CO₂ reading on the LCD will begin to approach 1000 ppm. Wait 1 to 2 minutes until the CO₂ reading stabilizes.

Enter the Setup menu and use the <MENU> key to advance to Calibrat 1000 PPM. Press and hold the <SAVE> key for 2 seconds and the display will change to Waiting Calibrat then to Waiting 5 minute to indicate that the device is calibrating. Again, this process takes about 5 minutes. When calibration is complete the unit will display the ppm value and Cal Done. Press the <SAVE> key to return to normal operation and shut the gas off.

20,000 PPM CALIBRATION

Connect the 20,000 ppm CO₂ and apply the gas as before. The LCD will begin to approach 20,000 ppm. Wait 1 to 2 minutes until the CO₂ reading stabilizes.

Enter the Setup menu and use the <MENU> key to advance to Calibrat 20,000 PPM. Press and hold the <SAVE> key for 2 seconds and the display will change to Waiting Calibrat then to Waiting 5 minute.

Again, wait 5 minute and when calibration is complete the unit will display the ppm value and Cal Done. Press <SAVE> to resume normal operation and shut the gas off.

Disconnect the tubing and replace the cap on the sensor chamber as calibration is complete.

DIMENSIONS

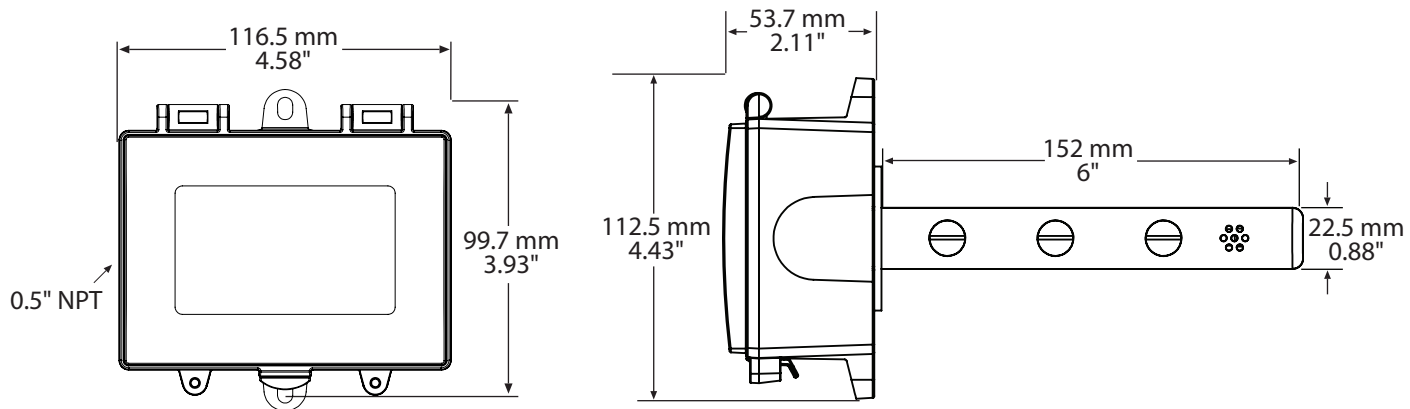

SPECIFICATIONS:

Power Supply	20 - 28 Vac/dc (non-isolated half-wave rectified)
Consumptions	Current: 120 mA max @ 24 Vdc, 212 mA max @ 24 Vac Voltage: 79 mA max @ 24 Vdc, 129 mA max @ 24 Vac
Output Signals.....	4-20 mA active (sourcing) or 0-5 Vdc / 0-10 Vdc (field selectable)
Output Drive Capability	550 ohms maximum for current output, 5 Kohm min for voltage output
Output Resolution	10 bit PWM
Input Voltage Effect.....	Negligible over specified operating range
Protection Circuitry.....	Reverse voltage protected, overvoltage protected
Operating Conditions	0-50°C (32-122°F), 0-95 %RH non-condensing
LCD Resolution	1 ppm CO ₂ , 1% RH, 1°C or 1°F
LCD Size	35 mm W x 15 mm H (1.4" x 0.6") alpha-numeric 2 line x 8 characters
Wiring Connections.....	Screw terminal blocks, 14 to 22 AWG
Enclosure	Duct mount, Grey polycarbonate with gasket, UL94-V0, IP65 (NEMA 4X) F style includes thread adapter (1/2" NPT to M16) and cable gland fitting 116.5 W x 112.5 H x 53.7 D mm (4.585" x 4.43" x 2.115")
Probe.....	152 mm L x 22.5 mm D (6" x 0.85")

CO2 SIGNAL

Measurement Type	Non-Dispersive Infrared (NDIR), diffusion sampling
Measurement Range.....	0-2000 ppm (Sensor 1) or 0-20,000 ppm (Sensor 2), programmable span
Standard Accuracy	+30 ppm +3% or reading (Sensor 1 0-2000 ppm range with Auto Cal), +75 ppm or 10% of reading (whichever is greater) (Sensor 2 0-20,000 ppm range with dual channel sensor)
Temperature Dependence	0.2 %FS per °C
Stability	2 %FS over life of sensor (15 years typical) Sensor 1 (0-2000 ppm), <5 %FS over life of sensor (15 year typical) Sensor 2 (0-20,000 ppm)
Pressure Dependence.....	0.13% of reading per mm Hg
Altitude Correction	Programmable from 0-5000 ft via keypad
Response Time	<2 minutes for 90% step change typical
Warm-up Time	<2 minutes

TEMPERATURE SIGNAL

Sensing Element.....	10K thermistor, +0.2°C (+0.4°F)
Range	0 to 35°C (32 to 95°F) or 0 to 50°C (32 to 122°F) selectable via keypad
Resolution	0.1°C or 0.1°F

RH SIGNAL

Sensor	Thermoset polymer based capacitive
Accuracy.....	±2 %RH
Range	0-100 %RH, non-condensing
Resolution	0.1 %RH
Hysteresis.....	±3 %RH
Response Time.....	15 seconds typical
Stability.....	±1.2 %RH typical @ 50 %RH in 5 years

OPTIONAL RELAY OUTPUT

Contact Ratings.....	Form A contact (N.O.), 5 Amps @ 250 Vac, 5 Amps @ 30 Vdc for resistive loads 2 Amps @ 250 Vac, 2 Amps @ 30 Vdc for inductive loads
Relay Trip Point.....	Programmable via keypad
Relay Hysteresis.....	Programmable via keypad

Country of Origin.....Canada