

INTRODUCTION

The room CO₂/RH/TT Transmitter incorporates three sensors and the room CO₂/T Transmitter incorporates two sensors in one attractive wall mount enclosure for the most efficient environmental monitoring and control system. It uses dual channel optics and LTA (long term adjustment) signal processing technology to monitor CO₂ levels within a range of 0 to 10,000 ppm, a field-proven RH sensor to monitor relative humidity from 0-100 %RH (If included in model ordered) and a thermistor to measure temperature over common field-selectable ranges. All measurements are continuously available on separate outputs as linear 4-20 mA or 0-5/0-10 Vdc signals. The device includes an LCD for configuration and operating parameters are programmed using a keypad for specific applications. Options include a control relay, override switch and slide pot set-point control.

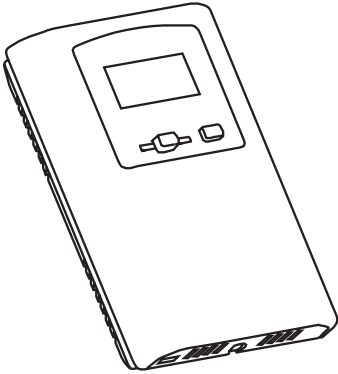

BEFORE INSTALLATION

Read these instructions carefully before installing and commissioning the device. Failure to follow these instructions may result in product damage. Do not use in an explosive or hazardous environment, with combustible or flammable gases, as a safety or emergency stop device or in any other application where failure of the product could result in personal injury. Take electrostatic discharge precautions during installation. **Do not exceed device ratings.**

NOTE: This CO₂ sensor incorporates a Self Calibration feature to correct CO₂ sensor drift. This feature is recommended for applications where the sensor will be exposed to fresh air (400 ppm CO₂) at least one hour per day. If the monitored space is occupied 24 hours or consistently maintains higher or lower levels of CO₂, it is recommended that this feature be turned off, but yearly calibration will be required. If the self calibration is disabled at installation time without allowing for 7 day auto calibration cycle, then a manual calibration should be performed to ensure accuracy of the device.

MOUNTING

The transmitter installs directly on a standard electrical box and should be mounted five feet from the floor of the area to be controlled. Do not mount the sensor near doors, opening windows, supply air diffusers or other known disturbances. Avoid areas where the detector is exposed to vibrations or rapid temperature changes.

The cover is hooked to the base at the top edge and must be removed from the bottom edge first. Use a small Phillips screwdriver to loosen the security screw as shown in Figure 1. Complete removal of the screw is not required. Use the screwdriver to carefully pry each bottom corner if necessary. Tip the cover away from the base and sit it aside as shown in Figure 2.

Sit the PCB aside until the base is mounted on the wall. For added protection, place the PCB in the supplied anti-static bag.

Mount the base by screwing to an electrical box or directly to the wall as shown in Figure 4. The mounting hole locations are shown on page 7

Figure 1

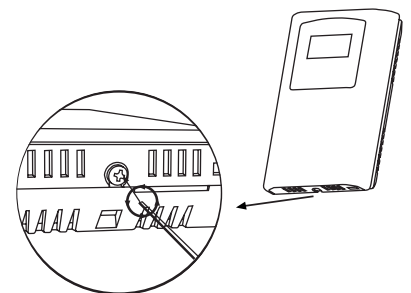
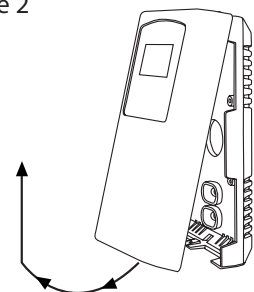
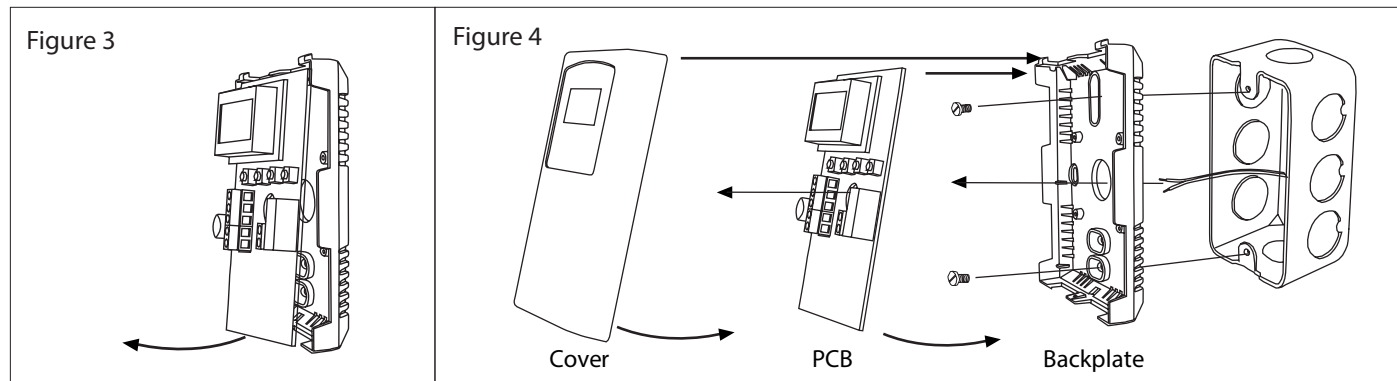

Figure 2



After the base is screwed to an electrical box or directly to the wall using the appropriate holes, remove the PCB from the anti-static bag, feed connection wires through the center hole and place the top of the PCB into the PCB holders on the backplate and snap the bottom of the PCB into place as shown in Figure 4.

Making wiring connections as per the Wiring illustrations and install the decorative cover by placing the top of the cover into the cover holder on the top of the backplate and snapping the bottom into place as shown in Figure 4. Tighten the security screw with a Phillips screwdriver.



WIRING

Deactivate the 24 Vac/dc power supply until all connections are made to the device to prevent electrical shock or equipment damage. Follow proper electrostatic discharge (ESD) handling procedures when installing the device or equipment damage may occur. Use 22 AWG shielded wiring for all connections and do not locate the device wires in the same conduit with wiring used to supply inductive loads such as motors. Make all connections in accordance with national and local codes.

This is a 3-wire sourcing device. Connect the plus dc or the ac voltage hot side to the PWR terminal. The supply common is connected to the COM terminal. The device is reverse voltage protected and will not operate if connected backwards. It has a half-wave power supply so the supply common is the same as the signal common.

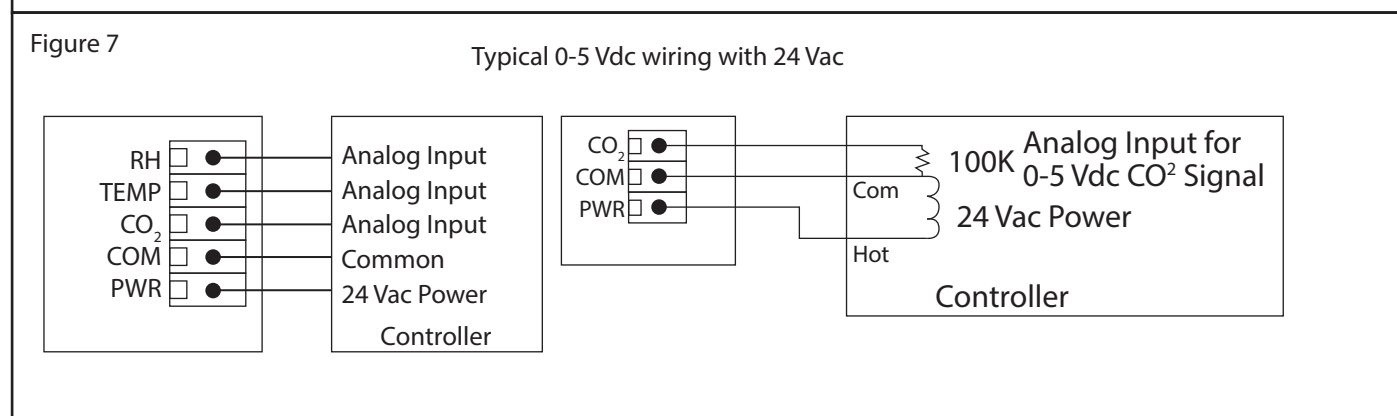
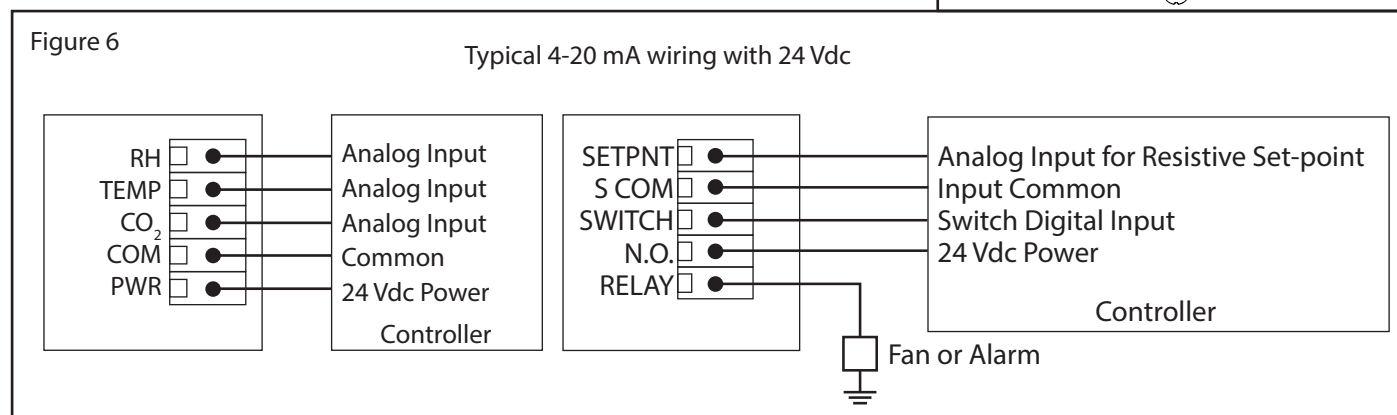
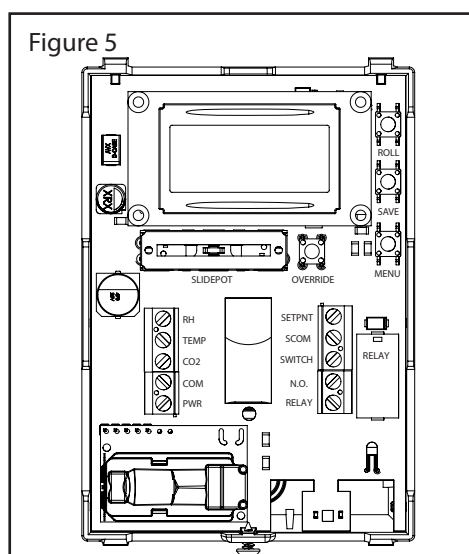

Several devices may be connected to one power supply and the output signals all share the same common. Use caution when grounding the secondary of a transformer or when wiring multiple devices to ensure the ground point is the same on all devices and the controller.

The analog outputs are available on the CO₂, RH (If option ordered) and TEMP terminals. The signal type can be ordered as either voltage or 4-20 mA active outputs. The voltage model is selectable for either 0-5 or 0-10 Vdc via the menu (the factory default is 0-5 Vdc). The current output operates in the active mode and does not require a loop power supply. This means that the signal current is generated by the transmitter and must not be connected to a powered input or device damage will result. Check the controller Analog Input to determine the proper connection before applying power. Both current and voltage signals are referenced to the COMMON terminal. The analog output signals are typically connected directly to the Building Automation System (B.A.S.) and used as control parameters.

An optional signal is the relay output available on the N.O. RELAY terminals. The relay output is completely isolated and has a Normally Open (NO) signal. This signal can be used to directly control an alarm or ventilation fan.

If installed, the override switch output is a two-wire dry contact normally open switch contact. The slide pot output is a two-wire resistive signal that can vary from 0-10K ohms with left-to-right slide pot action. Other resistive values are available on request and the slide pot may be configured as normal or reverse acting.

The override switch and slide pot share a single common labeled S. COM and this is not connected to the power supply COM.

START-UP

Verify the transmitter is properly wired and connections are tight. The LCD will indicate the software version number, the relay set-point (if installed), the CO₂ measurement range, the temperature range and then the device will begin reading the sensor values and display them on the LCD. The sensor will update the output and display every 4 seconds

OUTPUTS

The CO₂ output is scaled so that 4-20 mA (or 0-5/0-10 Vdc) equals 0 to Out High as set in the Setup Menu. Depending on the range configured in the menu, the factory default is 0-2000 ppm. The OUT_HIGH can be changed in the Setup Menu and the output signal is scaled accordingly.

The RH and temperature outputs operate similar to the CO₂ output. RH is scaled 0-100 % RH (If option ordered) and temperature defaults to 32 to 95°F but can be changed to 0 to 35°C, 0 to 50°C or 32 to 122°F using the Setup Menu.

For voltage output models, the factory default is 0-5 Vdc and can be changed to 0-10 Vdc in the Setup Menu.

OPERATION

The CO₂, RH, and Temperature signals are connected to the Building Automation System (BAS) analog inputs. The BAS reads the voltage or current signals and calculates actual values using correct scaling for the ranges and signal type. These values can be used to control ventilation devices or initiate alarms. All values are displayed locally on the LCD. The Setup Menu can be used to modify the displayed information.

This display is factory set to display all measurement values. The CO₂ level will continuously be displayed, while the RH (if RH option ordered) and Temp will alternate. The CO₂ level will be displayed as 0-2000 ppm to 10,000ppm depending on configuration setup, the %RH will be displayed as 0-99H and the temperature will be displayed as 0 to 50°C. The Setup Menu can be used to modify the displayed information. The installer can select to only display CO₂, or to display CO₂ and RH, or alternately CO₂ and temperature. The device supports four temperature ranges that may also be selected in the menu. The default is 0 to 50°C but this may be changed to 0 to 35°C and the output signal will stay the same. Also, the temperature range may be changed to 32 to 95°F or 32 to 122°F by changing the Temp Scale setting from C to F and the output scaling will change to match the display.

If the optional relay is installed it can directly control a small fan or alarm by setting the trip value and hysteresis to appropriate values. The relay status is not indicated on the device LCD.

The optional override switch provides a dry contact closure to a digital input of the BAS. The switch status is not indicated on the LCD.

The optional slide pot can be connected to an analog input of the BAC and will provide a linear resistance signal such as 0-10 KΩ (for example) to be used as a set-point control. The set-point value is not shown on the LCD.

CALIBRATION

The RH and temperature measurements typically do not need any calibration for the life of the product. Both values may have user offsets assigned in the Setup Menu.

CO₂ calibration with gas requires a field calibration kit with pressure regulator, necessary tubing and appropriate bottles of CO₂ gas. The model requires only a single point 1000 ppm calibration to meet specified accuracy

1000 PPM CALIBRATION

Connect the 1000 ppm CO₂ gas bottle to Regulator and Tubing with calibration hood. Place hood over CO₂ sensor flush with PCB and apply the gas. The CO₂ reading on the LCD will begin to approach 1000 ppm. Wait 1 to 2 minutes while the CO₂ reading stabilizes.

Enter the Setup menu and use the <MENU> key to advance to Calibrat 1000 PPM. Press and hold the <SAVE> key for 2 seconds and the display will change to Calibrat Done. Press the <SAVE> key to return to normal operation and shut the gas off.

SET-UP MENU

The menu has several items as shown below. Some items change depending on the hardware configuration and the CO₂ sensor. To enter the menu, press and release the <MENU> key while in normal operation. This enters the Set-up Menu, press the <MENU> key to advance to the next menu item. No values are saved or changed by using <MENU>. The <ROLL> key is used to make changes to program variables by scrolling through the available options. When a value is changed, use the <SAVE> key to save it to memory and advance to the next menu item.

Setup Menu operation is explained below, the factory default values are shown. Note that items that are not applicable to the hardware configuration are skipped on the device's setup.

Press and release the <MENU> key to enter the Setup Menu.

1. CO2 RANGE

Out High
2000 ppm

The CO₂ Span value controls the analog output scaling. CO₂ span can be changed from 1000 to 10,000 ppm in 500 ppm increments using <UP> or <DOWN>. If CO₂ Span = 2000 ppm, then the output signal is scaled 0-2000 ppm = 4-20 mA. Factory default is 2000 ppm.

<MENU> Press to advance to next menu item

2. LOCAL ALTITUDE

Altitude
0 m

Change for CO₂ local altitude correction. The default is 0 meters. Change by using the <ROLL> key from 0 to 2550 m in 50 m increments and press <SAVE> to save the change.

<MENU> Press to advance to next menu item

3. CAL MODE

Auto Cal
ON

The Self-Cal feature <MENU> when enabled requires the sensor to be exposed to fresh air for at least one hour every twenty-four hours. When first installed the sensor requires a minimum of seven days of operation with fresh air exposer daily to allow the algorithm to adjust for self-calibration. Default for device is having this feature enabled "ON". If disabling this feature a manual calibration should be performed to ensure accuracy of the device.

<MENU> Press to advance to next menu item

4. TEMP SCALE

Temp C/F
°C

The temperature scale defaults to Celsius (°C). It can be changed to Fahrenheit (°F) using the <ROLL> key. Save changes using the <SAVE> key.

<MENU> Press to advance to next menu item

5. TEMP RANGE

T Range
0-50°C

Two temperature ranges are available, 0 to 35°C (32 to 95°F) or 0 to 50°C (32 to 122°F). This can be changed using <ROLL> and saved with the <SAVE> key.

<MENU> Press to advance to next menu item

6. TEMPERATURE OFFSET

T Offset
0°F

This setting allows calibration of the temperature sensor. Use <ROLL> to scroll through the offset values for the temperature signal and display, then press <SAVE> on the desired value. -1 subtracts 1 degree from the temperature and 1 adds 1 degree to the temperature. The range is -5 to +5 °C or -9 to +9°F depending on the Temp Scale set in Step 4.

<MENU> Press to advance to next menu item

7. HUMIDITY OFFSET (ONLY IF OPTION ORDERED)

RH Offset
0 %RH

This item allows calibration of the RH sensor. Use <ROLL> to add an offset to the RH signal and display, then press <SAVE>. -1 subtracts 1 %RH and +1 adds 1 %RH. The range is -10 to +10.

<MENU> Press to advance to next menu item

8. DISPLAY MODE

Display
CO₂+RH+T

Select parameters normally displayed on the LCD. The default is CO₂ + RH + T. Use <ROLL> to scroll through options. CO₂ ppm, CO₂ + RH, CO₂ + Temp. Then press <SAVE>.

(Available display options dependent on device ordered.)

<MENU> Press to advance to next menu item

Only if **Relay** installed

The relay can be configured to use CO₂, Humidity or Temperature for trip point.

9. RELAY CONTROL

For Temperature control of Relay:

Relay As
Temp

For Humidity control of Relay

Relay As
RH

For CO₂ control of Relay:

Relay As
CO₂

<MENU> Press to advance to next menu item

10. SETPOINT

Relay SP
1000 ppm

The relay setpoint can be set between:
CO₂: 500 to 5000 in 100ppm increments
RH: 20 to 90%RH
Temp: 5 to 40C (40 to 100F)

<MENU> Press to advance to next menu item

11. HYSTERESIS

Relay Hy
50 ppm

The hysteresis can be set between:
CO₂: 25 to 200 in 25 ppm increments
RH: 5 to 20%RH
Temp: 1 to 5C (2 to 10F)
Save changes by using the <SAVE> key.

<MENU> Press to advance to next menu item

12. TEST

Relay
Test OFF

Use the <ROLL> key to toggle the relay ON or OFF for testing purposes. Press either <SAVE> or <MENU> to turn the relay off and advance to the next item.

<MENU>

Press to advance to next menu item

Only on Voltage Output Models

13. OUTPUT TYPE

Out Type
0-5 Vdc

Use the <ROLL> key to change the value to 0-10 Vdc if necessary. Press <SAVE> key to save changes.

<MENU>

Press to advance to next menu item

14. OUTPUT

Output
Test OFF

Use the <ROLL> key to toggle outputs OFF (normal operation), MIN (minimum output) or MAX (maximum output) for testing purposes. Press either <SAVE> or <MENU> to set it back to OFF and advance to the next step.

<MENU>

Press to advance to next menu item

16. CALIBRATION

Calibrat
1000 PPM

This item is used for 1000 ppm gas calibration and is explained in the *Calibration* section.

<MENU>

Press to advance to next menu item

17. BACKLIGHT

BackLite
Auto

This item is used to control the LCD Backlite. The settings are Auto, On and Off. The default is Auto. In Auto mode the backlite remains off during normal operation. When a button is pressed the backlite turns on. After 30 seconds of inactivity the backlight turns off. In On mode the backlite is always on. In Off mode the backlite is always off, even if a button is pressed. Use the <ROLL> key to select setting. Press the <SAVE> key to save the setting.

<MENU>

Press to advance to next menu item

18. RESTORE DEFAULTS

Restore
Defaults

Press the <SAVE> key to restore all factory defaults and calibration to original factory settings.

<MENU>

Press to advance to next menu item

19. EXIT

Menu
Exit

Press <SAVE> to exit the menu and return to normal operation, or <MENU> to repeat the menu.

SPECIFICATIONS

CO₂ SIGNAL

Measurement Type.....Dual Channel Non-dispersive Infrared
 Measurement Range0-10,000ppm adjustable, 0-2000ppm default
 Standard Accuracy± (30ppm + 3% of measured value)
 Temperature Dependence±2.5ppm/°C
 Altitude Correction.....Programmable from 0 to 2550m via menu
 Response Time20 seconds
 Life Span15 years typical

TEMPERATURE SENSOR

Sensing ElementPrecision NTC thermistor
 Accuracy.....±0.2°C @ 0 to 50°C (±0.36°F @ 32 to 122°F)
 Resolution0.1°C (0.2°F)
 Range0 to 35°C (32 to 95°F) or 0 to 50°C (32 to 122°F) selectable via menu

HUMIDITY SENSOR (If option ordered)

Accuracy.....±2 %RH
 Range0 to 100 %RH, non-condensing
 Resolution1 %RH
 Hysteresis.....±0.8 %RH @25°C (77°F)
 Response Time8 seconds
 Stability<0.25 %RH/year

OPTIONAL RELAY OUTPUT

Contact RatingsForm A contact (N.O.)
 2 Amps @30 Vac/Vdc
 Relay Trip PointProgrammable
 CO₂: 500 - 9000ppm via keypad, default is 1000ppm
 RH: 20 to 90%RH
 Temp: 5 to 40°C (40 to 100°F)
 Relay Hysteresis.....Programmable via keypad
 CO₂: 25-500ppm, default is 50ppm
 RH: 5 to 20%RH
 Temp: 1 to 5°C (2 to 10°F)

OPTIONAL LCD DISPLAY

Display Size35mm W x 15mm H (1.4" x 0.6") alpha-numeric 2 line x 8 character
 Resolution1ppm CO₂ 1 %RH, 1°C (1°F)
 BacklightAuto, On or Off via Setup Menu

GENERAL

Optional Override Switch.....Front panel push-button available as two wire dry-contact output
 Optional Setpoint ControlFront panel slidepot available as two-wire resistive output
 0-10 KΩ standard
 Power Supply20 to 28 Vac/dc (non-isolated half-wave rectified)
 Output Signals**Current:** 4-20 mA (Model CDD5A & E)
Voltage: 0-5 Vdc or 0-10 Vdc (Model CDD5B & F)
 Consumption.....**Current:**145 mA max @ 24 Vdc, 260 mA max @ 24 Vac (with all options)
Voltage: 85 mA max @ 24 Vdc, 150 mA max @ 24 Vac (with all options)
 Output Drive Capability.....**Current:** 550 Ω maximum
Voltage: 10 KΩ minimum
 Protection Circuitry.....Reverse voltage and output limited
 Operating Conditions.....0 to 50°C (32 to 122°F), 5 to 95 %RH non-condensing
 Sensor Coverage Area100m² (1000ft²) typical
 Wiring ConnectionsScrew terminal block (14 to 22 AW)
 EnclosureWhite ABS, IP30 (NEMA 1)
 84mm W x 119mm H x 29mm D (3.3" x 4.7" x 1.15")
 Country of OriginCanada
 Approval.....CE

DIMENSIONS

