

Introduction

The CO2 transmitter uses Infrared Technology to monitor CO2 levels and outputs a linear 4-20 mA or 0-5/0-10 Vdc signal. Options include an LCD, a control relay and a resistive temperature sensor. Features include a back-lit LCD and user menu for easy installation.

Before Installation

Read these instructions carefully before installing and commissioning the CO2 transmitter. Failure to follow these instructions may result in product damage. Do not use in an explosive or hazardous environment, with combustible or flammable gases, as a safety or emergency stop device or in any other application where failure of the product could result in personal injury. Take electrostatic discharge precautions during installation and do not exceed the device ratings.

Mounting

The CO2 enclosure should be mounted onto a flat surface three to five feet from the floor of the area to be controlled. The mounting hole locations are shown in the enclosure dimensional drawings. Do not mount the sensor near doors, opening windows, supply air diffusers or other known air disturbances. Avoid areas with vibrations or rapid temperature changes. Open the hinged cover by releasing the latch and connect the device according to the wiring instructions. After wiring and setup are complete, close and latch the cover. The cover may be secured with two self-tapping screws in the holes provided.

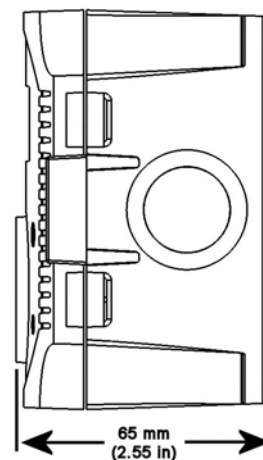
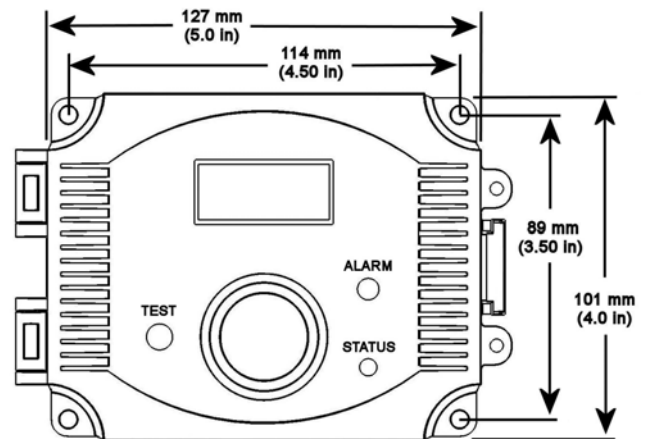

Wiring

Deactivate the 24 Vac/dc power supply until all connections are made to the device to prevent electrical shock or equipment damage. Follow proper electrostatic discharge (ESD) handling procedures when installing the device or equipment damage may occur. Use 22 AWG shielded wiring for all connections and do not locate the device wires in the same conduit with wiring used to supply inductive loads such as motors. Make all connections in accordance with national and local codes.

This is a 3-wire sourcing device. Connect the plus dc or the ac voltage hot side to the **POWER** terminal. The supply common is connected to the **COMMON** terminal. The device is reverse voltage protected and will not operate if connected backwards. It has a half-wave power supply so the supply common is the same as the signal common. Several devices may be connected to one power supply and the output signals all share the same common. Use caution when grounding the secondary of a transformer or when wiring multiple devices to ensure the ground point is the same on all devices and the controller.

The analog output is available on the **CO2** terminal. This signal is switch selectable for either voltage or 4-20 mA active output. In voltage mode the output is selectable for either 0-5 or 0-10 Vdc via the menu (the factory default is 0-5 Vdc). The current output operates in the active mode and does not require a loop power supply. This means that the signal current is generated by the transmitter and must not be connected to a powered input or device damage will result. Check the controller Analog Input to determine the proper connection before applying power. Both current and voltage signals are referenced to the **COMMON** terminal. The analog output signal is typically connected directly to the Building Automation System (B.A.S.) and used as a control parameter or for logging purposes.

An optional signal is the relay output available on the **N.O. RELAY** terminals. The relay output is completely isolated and has a Normally Open (NO) signal. This signal can be used to directly control an alarm or ventilation fan.

The two-wire resistive temperature sensor output signal can be ordered with various RTDs and thermistors to suit all control applications and is available on the **TEMP SENSOR** terminals.

Typical 4-20 mA wiring with 24 Vdc and all options

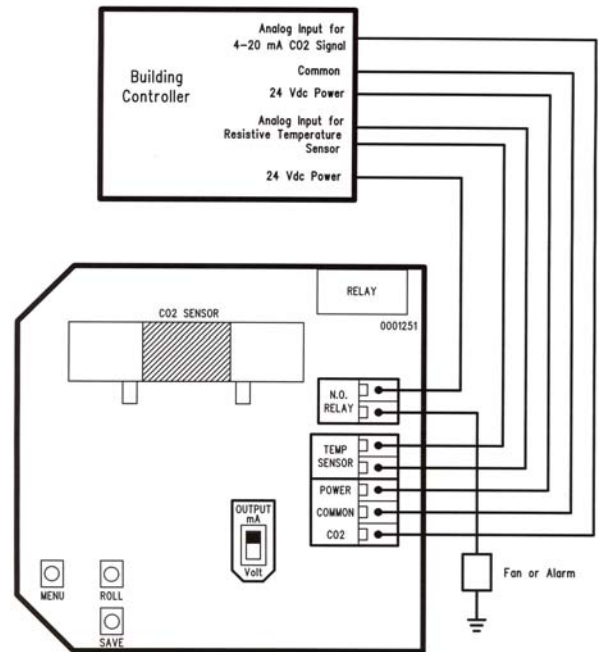

Typical 0-5 Vdc wiring with 24 Vac for CO2 only

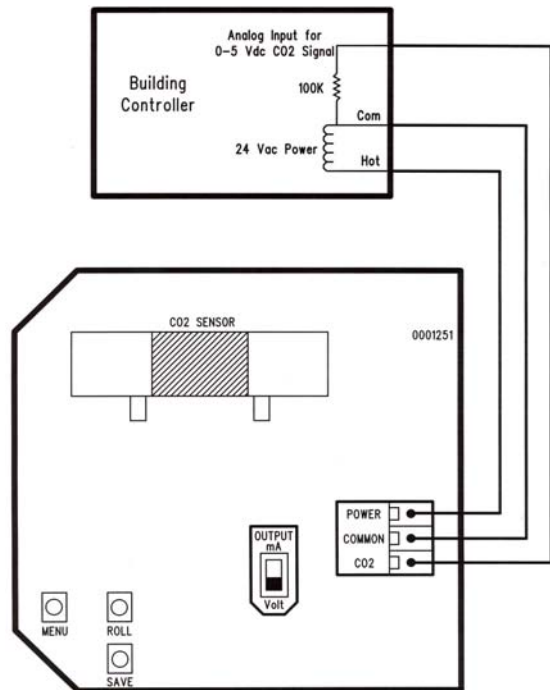

Start-up

Verify the device is properly wired and connections are tight. Ensure the V/I switch is set for the correct signal type. Apply power and the LCD will indicate the software version number, the output signal type, the relay setpoint (if installed), the CO₂ measurement range and then the sensor will begin reading the CO₂ level, output the correct analog signal and display the value on the LCD.

Output

The CO₂ output is scaled such that 4-20 mA (or 0-5/0-10 Vdc) equals 0 to Out_High. Depending on the model, the factory default is either 0-2000 ppm or 0-20,000 ppm. Out_High can be changed in the Setup Menu and the output is scaled accordingly. If using voltage output type, the default is 0-5 Vdc (0-10 can be selected in the menu).

Operation

The output signal is available on the **CO₂** terminal and is connected to the BAS analog input which reads the signal and calculates the CO₂ ppm value using correct scaling for the range and signal type. This CO₂ value is used to control output ventilation devices or initiate alarms. The CO₂ value is also displayed locally on the optional LCD.

If a relay is installed it can control a small fan or alarm by setting the trip value and hysteresis to appropriate values.

If a temperature sensor is installed it will be wired to an analog input of the BAS that is set for the specific resistance type. This could be a 10 K Ω thermistor, a 1000 ohm RTD or other sensor values. The BAS reads the resistance signal and converts it to a temperature value.

Calibration

Calibration with gas requires a field calibration kit with pressure regulator, necessary tubing and appropriate bottles of CO₂ gas. The CDD4B dual-channel sensor with extended range requires a 3-point calibration with 0, 1000 and 20,000 ppm gas (in order).

0 PPM Calibration

Turn the regulator knob off and attach it to the Nitrogen gas bottle and hand tighten. Remove the cover of the unit to be calibrated to expose the gas sensor chamber. The tubing from the gas bottle can be connected to either port on the chamber after the plastic cap is removed. Gently remove one cap and connect the tubing, note that strong shock or vibration can affect calibration.

Ensure the device has been operating normally for at least five minutes before applying gas. Turn the valve knob on the regulator to start the gas flow. The regulator will restrict the flow rate to the specified 100 ml/min. After a brief period the gas will flow into the chamber. Wait 1 to 2 minutes until the CO₂ stabilizes.

Enter the Setup menu and use the <MENU> key to advance to **Calibrat 0 PPM**. Press and hold the <SAVE> key for 2 seconds and the display will change to **Waiting Calibrat** then to **Waiting 5 minute** to indicate that the process of setting the internal calibration is taking place.

This takes about 5 minutes while the LCD counts down. Do not disturb the unit or the gas flow. When complete the unit will display the ppm value and **Cal Done**. Press <SAVE> to resume normal operation and shut the gas off.

1000 PPM Calibration

Connect the 1000 ppm CO₂ gas bottle and apply the gas as before. The CO₂ reading on the LCD will begin to approach 1000 ppm. Wait 1 to 2 minutes until the CO₂ reading stabilizes.

Enter the Setup menu and use the <MENU> key to advance to **Calibrat 1000 PPM**. Press and hold the <SAVE> key for 2 seconds and the display will change to **Waiting Calibrat** then to **Waiting 5 minute** to indicate that the device is calibrating. Again, this process takes about 5 minutes. When calibration is complete the unit will display the ppm value and **Cal Done**. Press the <SAVE> key to return to normal operation and shut the gas off.

20,000 PPM Calibration

Connect the 20,000 ppm CO₂ and apply the gas as before. The LCD will begin to approach 20,000 ppm. Wait 1 to 2 minutes until the CO₂ reading stabilizes.

Enter the Setup menu and use the <MENU> key to advance to **Calibrat 20,000 PPM**. Press and hold the <SAVE> key for 2 seconds and the display will change to **Waiting Calibrat** then to **Waiting 5 minute**.

Again, wait 5 minute and when calibration is complete the unit will display the ppm value and **Cal Done**. Press <SAVE> to resume normal operation and shut the gas off.

Disconnect the tubing and replace the cap on the sensor chamber as calibration is complete.

Setup Menu

The menu has several items shown below. Some items change depending on the hardware configuration and the CO2 sensor. To enter the menu, press and release the <MENU> key while in normal operation. This will enter the SETUP menu step 1, pressing <MENU> a second time advances to step 2. Each press of <MENU> advances the menu. No values are saved or changed by using <MENU>. The <ROLL> key is used to make changes to program variables by scrolling through the available options. When a value is changed, use the <SAVE> key to save it to memory and advance to the next menu item.

<MENU> Press and release the <MENU> key to enter the SETUP menu.

1. Out High 20000ppm The default range is 0-20,000 ppm. The span can be changed from 2000 to 20,000 ppm in increments of 500. Use the <ROLL> key to change the value and <SAVE> to save. The factory default is 20,000 ppm.

<MENU>

2. Altitude 0 Ft The default is 0 feet. Change by using the <ROLL> key from 0 to 5000 feet in 500 ft increments. Change for CO2 local altitude correction and press <SAVE> to save a change.

<MENU>

3. Relay SP 1000 ppm The relay trip setpoint default is 1000 ppm. It can be changed from 500 to 5000 in 100 ppm increments for the 2000 ppm CO sensor or 500 to 15,000 for the 20,000 ppm sensor. Save changes by using the <SAVE> key.

<MENU>

45. Relay Hy 50 ppm The relay hysteresis default is 50 ppm. This can be changed from 25 to 200 in 25 ppm increments for the 2000 ppm sensor or 25 to 500 ppm for the 20,000 ppm sensor. Use <SAVE> to save any change.

<MENU>

5. Relay Test OFF Use the <ROLL> key to toggle the relay ON or OFF for testing purposes. Press either <SAVE> or <MENU> to turn the relay off and advance to the next item.

<MENU>

6. Out Type 0-5 Vdc For voltage, the factory default output type is 0-5 Vdc. Use the <ROLL> key to change the value to 0-10 Vdc if necessary. Press the <SAVE> key to save. If the switch is set to mA, then 4-20 mA is displayed.

<MENU>

7. Output Test OFF Use the <ROLL> key to toggle the output OFF (normal operation), MIN (minimum output) or MAX (maximum output) for testing purposes. Press either <SAVE> or <MENU> to set it back to OFF and advance to the next item.

<MENU>

8. Calibrat 1000 PPM This item is used for 1000 ppm gas calibration and is explained in the *Calibration* section.

<MENU>

9. BackLite Enable Use the <ROLL> key to enable or disable the LCD backlight. When enabled the backlight is always on, when disabled it never lights. Press the <SAVE> key to save the setting. The factory default is Enable.

<MENU>

10. Menu Exit Press <SAVE> to exit the menu and return to normal operation or <MENU> to repeat the menu.

