

Room Carbon Dioxide Transmitter with BACnet®

Installation Instructions

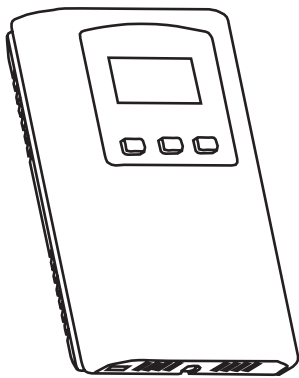

INTRODUCTION

The carbon dioxide transmitter uses Infrared Technology to monitor CO₂ levels within a range of 0 - 10,000 ppm. Options include a control relay, override switch, up/down set-point control, relative humidity sensor and temperature sensor.

The device includes native BACnet® protocol with 15 BACnet® objects and an RS-485 MS/TP network connection to offer a single-point solution for control of indoor air quality and comfort. Features include a back-lit LCD and user menu for easy installation, field-proven RH sensor and user input controls to add local set-point and override functions at the same network point.

BEFORE INSTALLATION

Read these instructions carefully before installing and commissioning the device. Failure to follow these instructions may result in product damage. Do not use in an explosive or hazardous environment, with combustible or flammable gases, as a safety or emergency stop device or in any other application where failure of the product could result in personal injury. Take electrostatic discharge precautions during installation. **Do not exceed device ratings.**

NOTE: This CO₂ sensor incorporates a Self Calibration feature to correct CO₂ sensor drift. This feature is recommended for applications where the CO₂ will be exposed to fresh air (400 ppm) at least one hour per day. If the monitored space is occupied 24 hours or consistently maintains higher or lower levels of CO₂, it is recommended that this feature be turned off, but yearly calibration will be required. If the self calibration is disabled at installation time without allowing for 7 day auto calibration cycle, then a manual calibration should be performed to ensure accuracy of the device. The Self Calibration feature can be set via the BACnet® Auto Cal Object. The default is ON.

MOUNTING

The transmitter installs directly on a standard electrical box and should be mounted five feet from the floor of the area to be controlled. Do not mount the sensor near doors, opening windows, supply air diffusers or other known disturbances. Avoid areas where the detector is exposed to vibrations or rapid temperature changes.

The cover is hooked to the base at the top edge and must be removed from the bottom edge first. Use a small Phillips screwdriver to loosen the security screw as shown in Figure 1. Complete removal of the screw is not required. Use the screwdriver to carefully pry each bottom corner if necessary. Tip the cover away from the base and sit it aside as shown in Figure 2.

Sit the PCB aside until the base is mounted on the wall. For added protection, place the PCB in the supplied anti-static bag.

Mount the base by screwing to an electrical box or directly to the wall as shown in Figure 4. The mounting hole locations are shown on page 4.

Figure 1

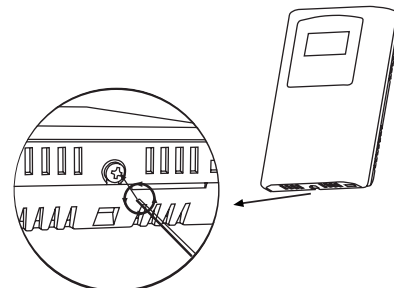

Figure 2

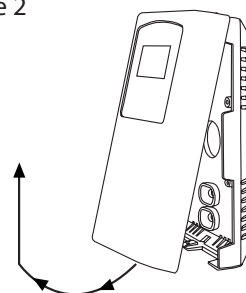

Figure 3

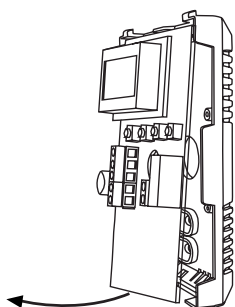
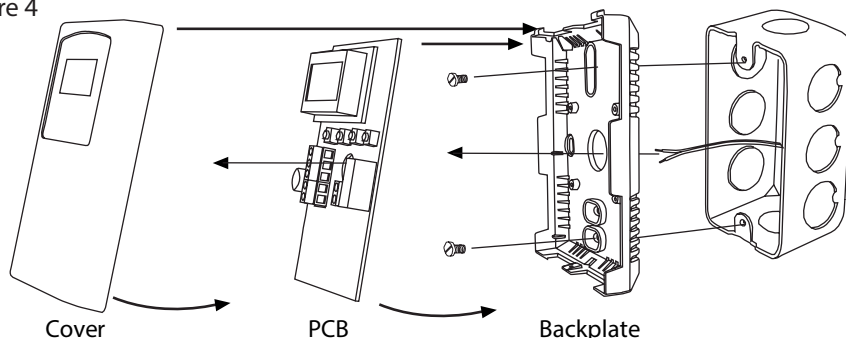

Figure 4



After the base is screwed to an electrical box or directly to the wall using the appropriate holes, remove the PCB from the anti-static bag, feed connection wires through the center hole and place the top of the PCB into the PCB holders on the backplate and snap the bottom of the PCB into place as shown in Figure 4.

Making wiring connections as per the Wiring Illustrations on page 2 and install the decorative cover by placing the top of the cover into the cover holder on the top of the backplate and snapping the bottom into place as shown in Figure 4. Tighten the security screw with a Phillips screwdriver.

WIRING

Deactivate the 24 Vac/dc power supply until all connections are made to the device to prevent electrical shock or equipment damage. Follow proper electrostatic discharge (ESD) handling procedures when installing the device or equipment damage may occur.

Use 22 AWG shielded wiring for all connections and do not locate the device wires in the same conduit with wiring used to supply inductive loads such as motors. Connect the cable shield to ground at the controller only. Make all connections in accordance with national and local codes.

Connect the 24 Vac/dc power supply to the terminals labeled POWER and COMMON. Use caution if 24 Vac power is used and one side of the transformer is earth grounded. In general, the transformer should

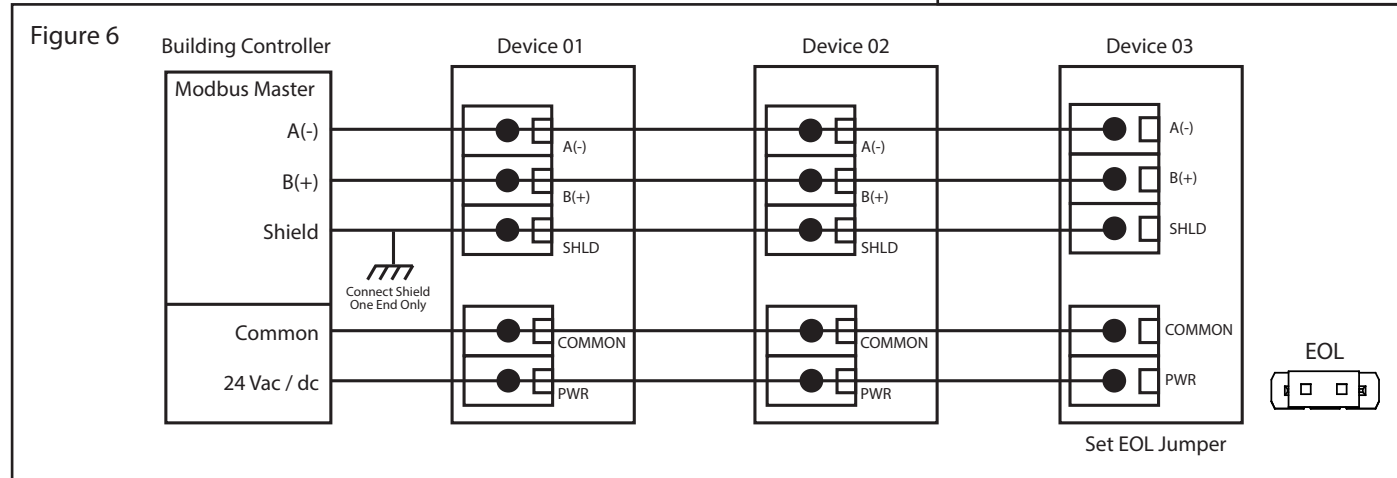
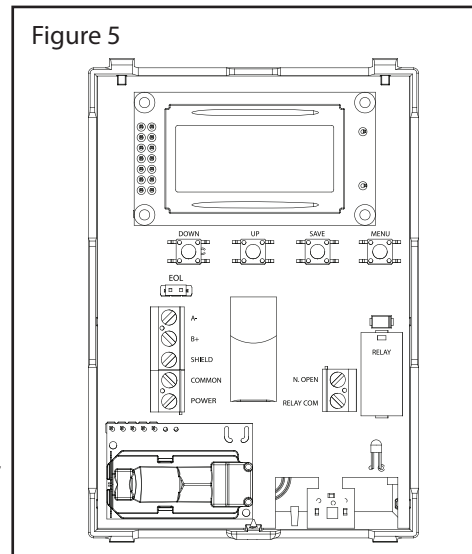

NOT be connected to earth ground when using devices with RS-485 network connections. The device is reverse voltage protected and will not operate if connected backwards.

Connect the RS-485 network with twisted shielded pair to the terminals marked A(-), B(+) and SHIELD. The positive wire connects to B(+) and the negative wire connects to A(-) and the cable shield must be connected to the SHIELD terminal on each device. If the device is installed at either end of an RS-485 network, and end-of-line (EOL) termination resistor (121 Ω) should be installed in parallel to the A(-) and B(+) terminals. This device includes a network termination jumper and will connect the (121 Ω) resistor correctly on the PCB. Simply move the jumper to the EOL position and no external resistor is required. The ground wire of the shielded pair should be connected to earth ground at the end of the network and the master is not grounded. Do not run bus wiring in the same conduit as line voltage wiring or other wiring that switches power to highly inductive loads such as contactors, coils, or motors.

A network segment is a single shielded wire loop run between several devices (nodes) in a daisy chain configuration. The total segment length should be less than 4000 feet (1220 meters) and the maximum number of nodes on one segment length is 64. Nodes are any device connected to the loop and include controllers but do not include the EOL terminators. To install more than 64 devices, or to increase network length, repeaters will be required for proper communication. The maximum daisy chain length (segment) depends on transmission speed (baud rate), wire size and number of nodes. If communication is slow or unreliable, it may be necessary to wire two daisy chains to the controller with a repeater for each segment.

An optional signal is the relay output available on the N. OPEN and RELAY COM terminals. The RELAY COM terminal is NOT connected to the power supply COMMON terminal. The relay output is completely isolated and has a Normally Open (NO) signal. This signal can be used to directly control an alarm or ventilation fan.

SET-UP

The device parameters must be set before connection to the network and will ensure each device will have a unique MAC address and Device Instance for start-up. On start-up, the MAC address is appended to the Device Object: Vendor Identifier to create the unique Device Instance (Device Object : Object Identifier). Once connected to a network, the Device Object : Object Identifier can be written to any unique value via BACnet® and then the MAC address will no longer be appended to the value. Once set, all parameters are saved in non-volatile memory. The local menu and LCD are used to set the BACnet® MAC device address (0-127) and the baud. The menu and set-up procedure is described in the Start-up section.

START-UP

Verify that the transmitter is properly wired and connections are tight. Apply power and note that the CO₂ sensor chamber light flashes on and off. The LCD will indicate the software version number, the Auto Cal status, the MAC ID, the Device Instance and the Baud Rate. Then the device will begin reading the sensor values and display them on the LCD. The sensor operates on a 4 second interval and will update the output and display every 4 seconds.

OPERATION

In normal operation the device reads the CO₂, RH, and temperature sensors and updates the object values accordingly. The LCD displays the sensor values as determined by the display mode object.

If the device has the optional Up/Down set-point switches installed, pressing either the <UP> or <DOWN> keys will cause the LCD to change to show the set-point value. The first key press will display the current setting of the Up/Down control from 0 to 100% (default). The display will show "Setpoint - xx%" for about 5 seconds and then revert back to the sensor values again if neither the <UP> or <DOWN> keys are pressed again. To increase the set-point, press the <UP> key while the LCD is in set-point mode and each press will increase the set-point by 10% up to the 100% maximum value. To decrease the set-point, press the <DOWN> key while the LCD is in set-point mode and each press will decrease the set-point by 10% down to the 0% minimum value. After 5 seconds of no key activity, the display will revert back to normal and the new set-point value will be saved.

The set-point scale can be configured via the menu. Various options are available such as temperature ranges in °C or °F, %RH values or ppm values. See the Setup Menu section for more details. Changing the scale in the menu will affect the BACnet® object and the LCD display of the set-point values.

If the device has the optional Override switch installed, pressing the <OVERRIDE> key will cause the LCD to change to show the override status. The display will show "Override - ON" for about 5 seconds and then revert back to the sensor values again. The override cannot be turned OFF with the switch, it must be reset via the BACnet® Override Switch object.

SET-UP MENU

The menu has several items as shown below. To enter the menu, press and release the <MENU> key while in normal operation. This will enter the Setup Menu, pressing the <MENU> key a second time advances to the next menu item. The <UP> and <DOWN> keys are used to make changes to program variables by scrolling through the available options. When a value is changed, use the <SAVE> key to save it to memory and advance to the next menu item.

Setup Menu operation is explained below, the factory default values are shown. Note that items that are not applicable to the hardware configuration are skipped on the device's setup.

Press and release the <MENU> key to enter the Setup Menu.

1. BAUD RATE

BaudRate
9600

Use the <UP> or <DOWN> keys to select a baud rate of 9600, 19200, 38400, 57600 or 76800, 115200. Press <SAVE> key to save the change.

<MENU> Press to advance to next menu item

2. MAC ADDRESS

MAC Addr
3

Press the <UP> or <DOWN> keys to select a unique network address from 0-127. Press the <SAVE> key to save the change.

<MENU> Press to advance to next menu item

3. CALIBRATION

Calibrat
1000 ppm

This item is used for 1000 ppm gas calibration and is explained in the *Calibration* section.

<MENU> Press to advance to next menu item

Only if Relay Option Installed

4. RELAY

Relay
Test OFF

Use the <UP> or <DOWN> keys to toggle the relay ON or OFF.

<MENU> Press to advance to next menu item

Only if viewable LCD Installed

5. BACKLIGHT

BackLite
Auto

Use the <UP> or <DOWN> keys to set LCD backlight control. Options are OFF, ON or AUTO (will light when buttons are pushed).

<MENU> Press to advance to next menu item

Only if Set-point Option Installed

6. SET-POINT

Setpoint
Mode %

Use the <UP> or <DOWN> keys to select the set-point mode. The default is % for 0-100% (10% steps).

This can be changed to one of the following selections:

- °C1 for 18-24°C set-point (0.5°C steps)
- °C2 for 10-45°C set-point (0.5°C steps)
- °F1 for 67-73°F set-point (1°F steps)
- °F2 for 50-113 °F set-point (1°F steps)
- ppm for 500-1500 ppm set-point (50 ppm steps)
- % for 30-70 %RH set-point (1 %RH steps)

NOTE: C1, C2 or F1 or F2 will be shown based on temperature unit setting through network.

<SAVE> Press to exit the menu and return to normal operation or <MENU> to repeat the menu.

SPECIFICATIONS

CARBON DIOXIDE SENSOR

Measurement TypeDual Channel (NDIR)
Measurement Range.....0-10000 ppm
Sensor Accuracy.....± (30ppm + 3% of Measured Value)
Temperature Stability±2.5ppm/°C
Repeatability.....±10ppm
Life Span15 years typical
Response Time<20 seconds
Warm-up Time2 minutes
Altitude CorrectionProgrammable from 0-5000 ft via BACnet®
Coverage Area100 m² (1000 ft²) typical

INTERFACE

Hardware2 wire RS-485
Software.....BACnet® - MS/TP protocol
Baud RateBACnet® - Locally set to 9600, 19200, 38400, 57600, 76800 or 115200
Address Range.....BACnet® - Locally set to 0-127 (factory default is 3),
(63 devices max on one daisy chain)

LCD DISPLAY

Resolution1 ppm CO₂, 1 %RH, 1°C (1°F)
Size.....35mm W x 15mm H (1.4" x 0.6") alpha-numeric 2 line x 8 characters
Backlight.....ON, OFF or AUTO via keypad

OPTIONAL TEMPERATURE

Sensing Element.....NTC thermistor, ±0.2°C (±0.4°F)
Resolution0.1°C (0.2°F)
Range.....0 to 50°C (32 to 122°F)
Accuracy±0.2°C @ 0 to 50°C (±0.36°F @ 32 to 122°F)

OPTIONAL RELATIVE HUMIDITY

SensorThermoset polymer based capacitive
Accuracy±2 %RH
Range.....0-100 %RH, non-condensing
Resolution1 %RH
Hysteresis±0.8 %RH @25°C (77°F)
Response Time8 seconds typical
Stability<0.25 %RH/year

OPTIONAL RELAY OUTPUT

Contact Ratings.....Form A contact (N.O.), 2 Amps @ 140 Vac/30 Vdc
Relay Trip Point.....Programmable 500 to 1500 ppm via BACnet®
Relay Hysteresis.....Programmable 25 to 200 ppm via BACnet®

GENERAL

Power Supply..... 24 Vdc ±20% or 24 Vac ±10% (non-isolated half-wave rectified)
Consumption..... 80 mA max @ 24 Vdc, 140 mA max @ 24 Vac with all options
Operating Conditions..... 0 to 50°C (32 to 122°F), 0 to 90 %RH non-condensing
Optional Override Switch..... Front panel pushbutton available as BACnet®
Optional Set-point Control.... Front panel push-buttons available as 0 to 100% as BACnet® object
Wiring Connections..... Screw terminal block (14 to 22 AWG)
Enclosure White ABS, IP30 (NEMA 1)
84mm W x 119mm H x 29mm D (3.3" x 4.7" x 1.15")
Country of Origin..... Canada
Approvals..... CE

CALIBRATION

Calibration with gas requires a field calibration kit consisting of an LCD, a bottle of 1000 ppm CO₂ gas, a tank pressure regulator with flow restricter and the necessary tubing to connect to the device.

Note that because of the Automatic Calibration Mode and other technology incorporated into the CDD series, only a single point 1000 ppm calibration is required to meet specified accuracy.

Turn the regulator on/off knob fully off and attach it to the 1000 ppm CO₂ gas bottle and firmly tighten it by hand. Remove the cover of the unit to be calibrated to expose the gas sensor. Place the Calibration hood over the sensor ensuring it contacts the PCB below sensor. the valve knob on the regulator to let the gas begin flowing.

The regulator will restrict the flow rate to the specified 100 ml/min. After a brief period the gas will flow into the chamber and the CO₂ reading on the LCD will begin to approach 1000 ppm. Wait 1 to 2 minutes until the CO₂ reading stabilizes.

Enter the Setup menu and use the <MENU> key to advance to Calibrat 1000 PPM. Press and hold the <UP> key for 3 seconds and the display will change to Calibrat Done. Press the <SAVE> key to return to normal operation and then the gas can be shut off.

Remove the calibration hood from the unit.

DIMENSIONS

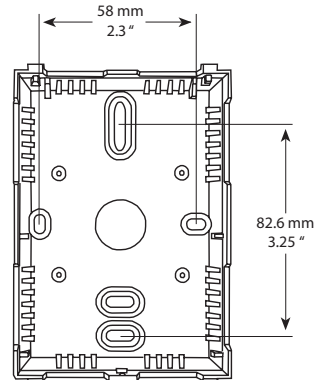
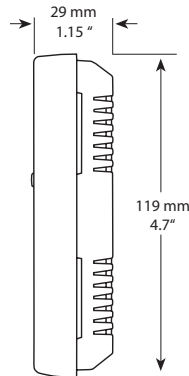
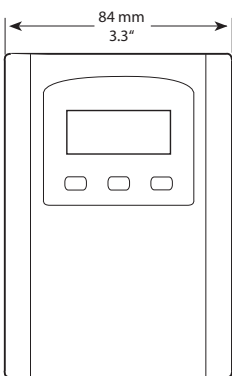

NETWORK SETUP GUIDE

The network setup guide describes the implementation of the BACnet® protocol. It is intended to assist control system programmers who may need to add support to their systems to communicate with the device.

BACnet® setup guide download is available online.



BACnet® PROTOCOL

<https://downloads.greystoneenergy.com/SG/SG-CDD3A1XXXBAC-003.pdf>